

Index

1. A word beforehand

- 1.1 Reliable instructions and recommendations
 - 1.1.1 Inspection of the materials delivered

2. Preparing the subfloors

- 2.1 Inspecting and preparing floor surfaces
- 2.2 Cement bonded subfloors
- 2.3 Bitumen bonded subfloors
- 2.4 Computer subfloors
- 2.5 Anhydrite subfloors
- 2.6 Extremely smooth and dense floors
- 2.7 Subfloors with an existing hard covering
- 2.8 Wooden floors
 - 2.8.1 General preparations
- 2.9 Floors on which a previous covering was adhered

3. Fitting Desso broadloom carpet

- 3.1 Preliminary remarks
 - 3.1.1 Inspecting the floor
 - 3.1.2 Site conditions for fitting
 - 3.1.3 Preparatory steps before installing carpet strips
- 3.2 Adhering or stretching
 - 3.2.1 Tufted contract qualities
 - 3.2.2 Woven contract qualities
- 3.3 Fitting direction
- 3.4 Seam positioning
- 3.5 Cutting
- 3.6 Cutting of the seams
 - 3.6.1 Backing edges
 - 3.6.2 Butt joining
 - 3.6.3 Cutting the sides
- 3.7 Adhering
- 3.8 After application of the adhesive
- 3.9 Stretching carpet onto underlay and spiked strips
- 3.10 Removable installation
- 3.11 Patterned carpet
 - 3.11.1 Pattern shifting (run out)
 - 3.11.2 Pattern shift between pieces from the same production
 - 3.11.3 Bowing
 - 3.11.4 Measuring up
 - 3.11.5 Laying patterned contract carpets
- 3.12 Wheelchair resistant adhering
- 3.13 Adhering carpet with underfloor heating
- 3.14 Adhering carpet with low electrical resistance values

4. Fitting Desso carpet on stairs

- 4.1 General
- 4.2 Carpet pile direction
- 4.3 Old stairs with worn treads
- 4.4 New wooden stairs
- 4.5 Old hard stone, tiled and concrete stairs
- 4.6 New concrete stairs finished with a cement coating
- 4.7 Adhering carpet on stairs
- 4.8 Carpeting stairs using the stretching method

5. Fitting Desso carpet tiles

- 5.1 Preparatory work
- 5.2 The subfloor
 - 5.2.1 Concrete floors
 - 5.2.2 Anhydrite floors
 - 5.2.3 Wooden floors
 - 5.2.4 Dusty floors
 - 5.2.5 Other floors
- 5.3 Important considerations concerning the floor
- 5.4 Recommendation
- 5.5 Guarantee
- 5.6 Protection during and after installation
- 5.7 Laying Desso carpet tiles
 - 5.7.1 Cutting to skirting boards
 - 5.7.2 Effects
 - 5.7.2.1 Quarter-turn appearance
 - 5.7.2.2 Monolithic appearance
 - 5.7.2.3 Brick wise appearance
 - 5.7.2.4 Ashlar appearance
 - 5.7.3 Raised flooring systems
 - 5.7.4 Underfloor heating
 - 5.7.5 Castor chairs
 - 5.7.6 Stairs
 - 5.7.7 Skirting board

6. Needle felt carpet

- 6.1 Influential factors of contract environment
- 6.2 Subfloor
- 6.3 Cutting
- 6.4 Special requirements with patterned needle felt
- 6.5 Adhering

Installation of Desso contract carpet and carpet tiles

1. A word beforehand

The greatest possible care has been given to manufacturing Desso carpet and carpet tiles. You can be rest assured that on leaving the factory the carpet and carpet tiles fully meet all the specifications described in the relevant product documentation fully. Desso carpet and carpet tiles however only really come to life in the interior. It is therefore of great importance that the instructions below are followed very carefully. Only then can you be assured of an optimum result.

1.1 Reliable instructions and recommendations

The instructions and recommendations concerning the handling and fitting of Desso carpet and carpet tiles are based on extensive tests carried out in our laboratory and years of practical experience. Although Desso guarantee the accuracy of their advice, no responsibility whatsoever can be taken for work, instructions and/or descriptions supplied by any third party.

Should you have any questions in that respect the Technical Services Department at Desso would be pleased to assist you. Carpet is our trade, and there really is virtually nothing in that area for which we will be unable to offer you an appropriate solution.

1.1.1 Inspection of the materials delivered

Desso stresses that you should always inspect the carpet delivered to you before commencing fitting. Every order is handled by Desso with the greatest possible care. Inspections are however always carried out under conditions that are different to those under which the carpet is to be fitted. It is therefore to your own advantage to ensure that a thorough inspection is made. Make sure that the quality, colour, pattern, etc. correspond exactly with your order. Always register any complaint before commencing cutting or fitting. Only then will we be able to accept and process any complaint further.

Preparing the subfloors

2.1 Inspecting and preparing floor surfaces

When fitting carpet the subfloor always demands special attention. The subfloor quite literally forms the base on which the carpet has to display its qualities and characteristics. Aspects such as damp, levelness and compression strength are extremely important in that respect. Requirements differ with the type of subfloor involved. The various types concerned are described separately below. In general it can be said that the subfloor must comply with the relevant standards, as mentioned in the appendix, which includes several International Standards.

Note: if in your case a subfloor is involved that is not discussed here, please contact the Technical Services Department at Desso beforehand. We will then be able to advise you with respect to floor conditions in relation to the application options for Desso contract carpet.

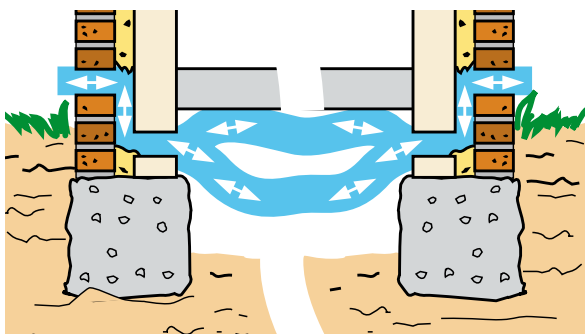

suspended, well ventilated subfloor

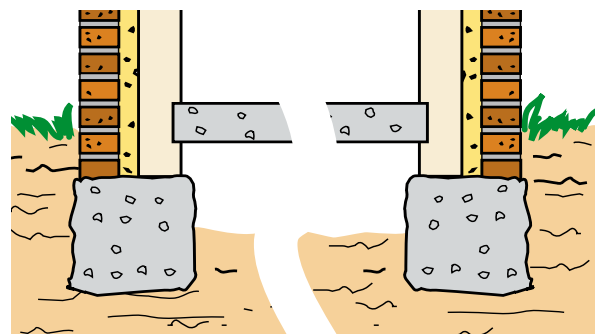

suspended, unventilated subfloor

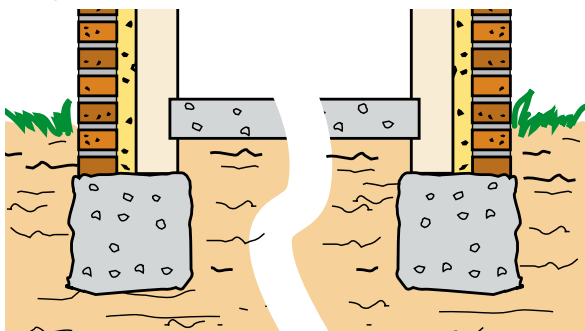

unsuspended subfloor



2.2 Cement bonded subfloors

Always check a cement bonded subfloor for damp. With the standard CM-measurement the damp content should never exceed 3%. Using the the alternative protimeter measurement method the damp content should never exceed 5 %. Furthermore, the subfloor should also be continuously dry. Check the ventilation under the floor and in the

outer walls. As a rule there should be 5 cm² ventilation per m² of floor surface.

A suspended cement-bonded subfloor demands a good isolation layer. The subfloor should also be clean, flat, solid and free from grease. There should be no cracks, loose flaky areas or irregularities present. In case the subfloor is granular, rough or uneven it will require levelling. Porous and/or granular subfloors should first be prepared using a acrylic or polyurethane based primer. If applicable an acrylic based primer is preferable, but that form of preparation is the least environmentally friendly. The instructions for the product concerned should therefore be followed extremely carefully. Sand off any irregularities and level using a waterproof cement based, or latex levelling compound. Sand wherever necessary when dry.

2.3 Bitumen bonded subfloors

Level bitumen bonded subfloors and bitumen insulation layers using a cement based waterproof levelling material. Sand wherever necessary when dry. When levelling a cast asphalt floor any abrasive sand used should be removed beforehand.

2.4 Computer subfloors

Computer subfloors usually consist of heightened floor elements measuring 60 x 60 cm, which are fastened on separate jacks. The individual floor elements can be made of wood, anhydrite, concrete or metal. The jacks have to be fixated and well-glued to guarantee the conduction of person-charge. Considering this conduction, it is a good idea to glue every 40 m² 1,25 meter of copper band to the subfloor, making sure that this copper band is adequately earthed.

Both with carpet tiles and carpets a conducting type of glue or tackifier should be used. The copper band should be installed transversely underneath the carpet material. Computer subfloors have to comply with several requirements. Differences in height between the panels may not exceed 1 mm. Also the room between the panels may not exceed 1 mm. Furthermore, the floor elements should never wobble or creak.

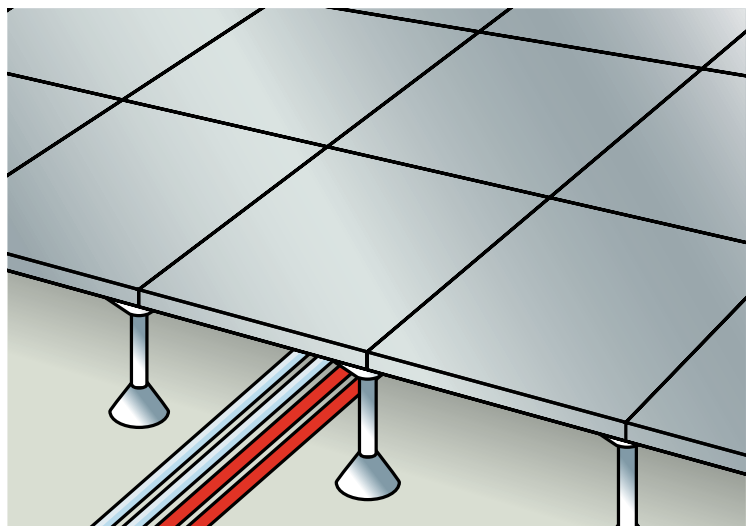

2.5 Anhydrite subfloors

Anhydrite floors will require sanding and vacuum cleaning before commencing the fitting of the carpet. Prior application of a primer or adhesion layer, whether or not in combination with any levelling, may also be necessary. In case of any doubt we recommend contacting the Technical Services Department at Desso for further information.

2.6 Extremely smooth and dense floors (e.g. Granito tiles or Terrazzo)

Levelling is also often necessary on smooth and dense floors, especially if there are any rough spots on the surface. Tiled floors often require levelling. First ensure that a good adhesion surface exists by applying a primer before levelling. In case any 'sagging' occurs along the joins or seams levelling will have to be repeated. Sand wherever necessary, when dry and hard.

2.7 Subfloors with an existing hard covering

In case the subfloor has already been finished with a hard covering such as linoleum, PVC or suchlike, the following precautions should be taken. Check whether all of the existing covering is still firmly attached to the floor surface. If any areas are damaged they will have to be repaired first! Degrease the entire floor and allow it to dry thoroughly. Apply an adhesive layer for the benefit of the adhesive bed. If repair is not entirely possible throughout the existing covering should be removed completely.

Note: if you have removed the existing covering as a result of irreparable damage, before proceeding any further read the remarks in the section entitled 'Floors on which a previous covering was adhered'. The instructions described in that section should be followed very carefully.

2.8 Wooden floors

Wooden floors in particular, despite being fitted with a hardboard finishing layer, can nevertheless cause the formation of impressions in the carpet over the course of time. That also applies to the hardboard itself as a consequence of the natural working of the underlying wood. The best solution for this problem is a subfloor constructed from e.g. plywood, hardboard or MDF. In that manner sufficient solidity can be obtained to prevent any impressions of the underlying floor from forming.

In general it can be said that a wooden floor never possesses absolute solidity by definition. All the more reason for paying the utmost attention to the finishing layer.

2.8.1 General preparations

First check the floor ventilation and take any measures considered necessary. As a rule 5 cm² per m² of floor surface is sufficient. Following that, check the floor for loose boards etc. and replace or nail them into position as necessary. Make the floor dust-free.

Note: you should make a clear distinction between old and new wooden floors. Old floors virtually always require levelling, as the floorboards become warped and sag in the course of time. Level the floor using a cement based, elastic, waterproof levelling medium. New

wooden floors should not be levelled as the wood has not yet seasoned. With the seasoning of the wood the levelling medium would become loose and break up. Once the necessary distinction between old and new wooden floors as described above has been made, prepare with hardboard or chipboard. This should be performed on the basis of the applicable description below.

After you have made the already mentioned distinction between new and old wooden subfloor, you apply a leveling layer from for instance plywood, hardboard or MDF, following the supplier's instructions.

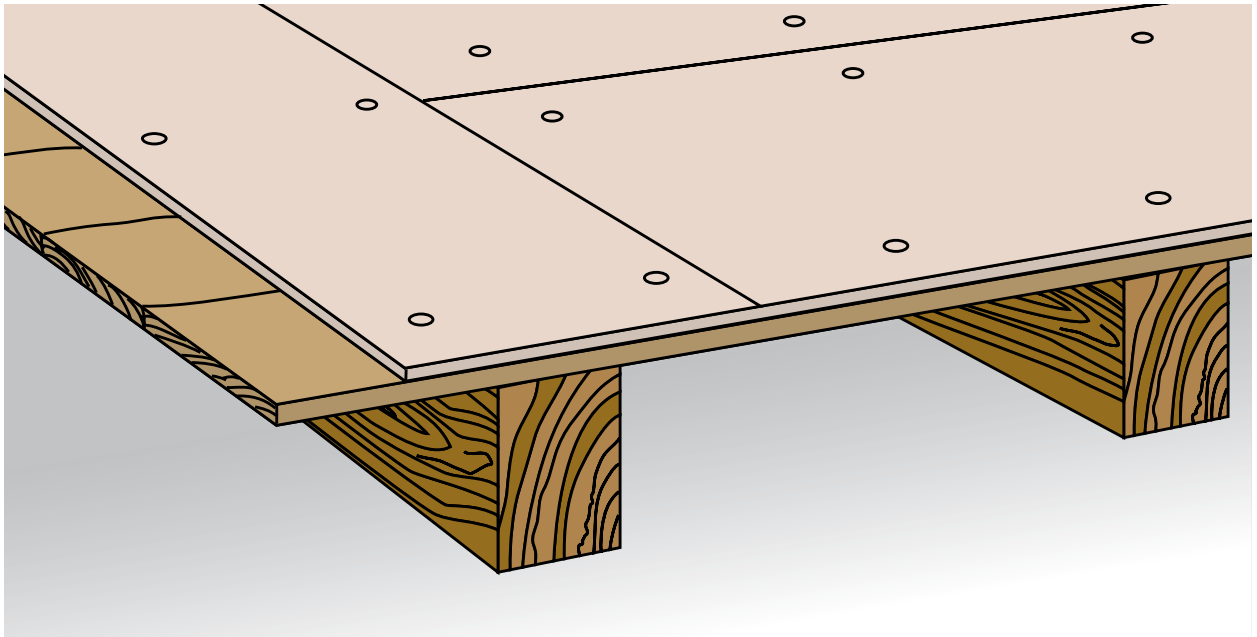

2.9 Floors on which a previous covering was adhered

All floors on which some form of covering was previously adhered require a thorough inspection. Once the old covering has been removed the subfloor will almost certainly show signs of damage. Furthermore, some old adhesive will also inevitably be left remaining. Always remove any old adhesive first, thoroughly remove all dirt and dust from the floor and apply a primer or adhesive layer and allow it to dry thoroughly. The floor should then be levelled and sanded wherever necessary.

Fitting Desso broadloom carpet

3.1 Preliminary remarks

Before commencing the fitting of Desso contract carpet please pay attention to the following general remarks.

3.1.1 Inspecting the floor

A detailed inspection of the floor and materials is essential. The need to inspect the floor for damp, ventilation, etc. has already been discussed extensively. Please refer to the relevant passages in the first part of chapter 2.

3.1.2 Site conditions for fitting

In cold and damp periods the carpet must be allowed to acclimatise for at least 24 hours in the surroundings in which it is to be laid. Only then may a start be made with fitting. Furthermore, when fitting Desso contract carpet a minimum working temperature of 15 C is essential. Humidity, especially when adhering, may also be an influencing factor and therefore has to be taken into account. Follow the instructions of the manufacturer of the adhesive.

For rooms with floor heating systems, the only technique applied is full adhesion. The heating temperature needs to be reduced 24 hours before installing; 48 hours after installation is completed, the heating system can be turned up slowly. During wintertime, the floor temperature has to be reduced to a level between 15° and 18°C.

3.1.3 Preparatory steps before installing carpet strips

The following preparations always have to be done before installing sheets of floorcovering:

- First step is the planning and lay out of the strips. There is no absolute rule. The number of seams should be reduced to a minimum. In areas with heavy and directed traffic, traffic flow should be along rather than across the seams. Joints are always fitted on top of each other, never next to each other. Exception here is the installation with carpet grippers, where sheets are joined exactly next to each other by sewing or gluing.
- Second step: fitting and trimming of the floorcovering. Pay attention to the squareness and the overlapping of the edges during cutting to achieve invisible seams. Also pay

attention to extra material to cover door openings.

The above mentioned steps are just very general rules. In the next paragraphs we will deal more specifically with the different techniques of installing carpet strips.

- Second step: fitting and trimming of the floorcovering. Pay attention to the squareness and the overlapping of the edges during cutting to achieve invisible seams. Also pay attention to extra material to cover door openings. The above mentioned steps are just very general rules. In the next paragraphs we will deal more specifically with the different techniques of installing carpet strips.

3.2 Adhering or stretching

When adhering or stretching Desso carpet a clear distinction should be made between tufted and woven carpets.

3.2.1 Tufted contract qualities

All tufted project qualities from Desso can be adhered to a good subfloor without any problem. Tufted qualities are generally not suitable for stretching.

3.2.2 Woven contract qualities

On a sound subfloor woven qualities can be both adhered and stretched. It is suggested (for a more luxurious installation) that wherever possible woven qualities be fitted over an underlay. This is ideal as far as wear resistance and durability are concerned. However this will increase rolling resistance and reduce wheelchair resistance. The heavy contract grade woollen qualities with a dense pile can also be adhered directly if required.

Note that woven carpets behave different under tension compared to tufted carpets with a simple foam or jute backing, due to the different production process. They have a better elasticity, which allows the use of a knee kicker and elongation in length direction (production direction). Tufted carpets which are more rigid, require a power stretcher.

Note that panels of softboard are not resilient and can not serve as a replacement of an underlay. They only have a levelling function for the subfloor and always have to be provided with an adequate pressure-layer like water resistant hardboard (Masonite) on which the carpet can be adhered.

3.3 Fitting direction

Before the carpet is cut the correct fitting direction should be determined. We recommend selecting this in such a manner that the carpet is viewed in the direction of the pile when entering the room: the carpet then appears at its best. You may of course also choose a different direction when the practical arguments outweigh any purely aesthetic reasons. Our remarks regarding the direction of fitting should therefore only be viewed as a suggestion in relation to aesthetic aspects. Wherever possible the sections of carpet should be fitted at right-angles in relation to the windows, which will minimise the visibility of any seams. Ensure, wherever possible, that the direction of fitting is the same everywhere over an entire floor of a building. Pay particular attention to L-shaped corridors etc. In corridors and relatively long areas it is usually preferable to lay the carpet lengthwise. Ensure that no seams are located near entrances. With patterned carpet the direction of fitting also has to take the pattern into account in relation to the walls, floor connections or furniture.

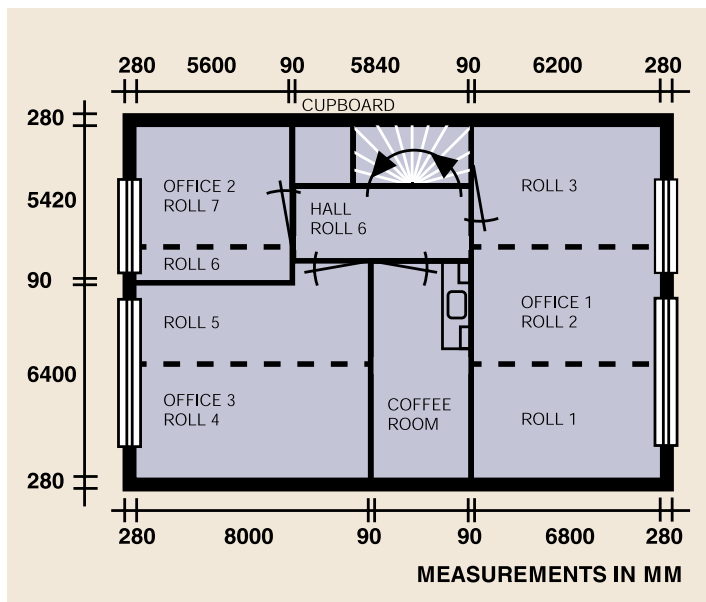

3.4 Seam positioning

It is always important to prepare floor layout and seam position before ordering a carpet. Desso can then take that into account when preparing the roll lengths, especially in the case of special productions. Please pay special attention to patterned carpets. Note the repeat length of the pattern provided in the official product specifications. See for further details the paragraph dealing specifically with patterned carpets. With piece dyed qualities one should make sure that the sections of carpet be laid continuously along the outer edges of

the carpet breadth, i.e. that no fitting sections have to be cut out of the centre of the width for fitting against the outer edges of full section widths. When providing a seam plan it is also necessary to provide a fitting sequence that can be taken into account for the sequence of production rolls.

3.5 Cutting

Once the fitting direction has been determined a start can be made on cutting the carpet. Always maintain an oversize of ± 5 cm per section. Lay the sections out in the same direction next to each other. Pay particular attention to the pile direction. All pile must face in the same direction. Ensure to make allowance for pattern repeat where appropriate. With woven carpet the marking thread on the back can serve as a useful aid. Always keep the marking thread on the same side. For felt and tufted carpet pay attention to the direction of the arrow or marks on the back: these must always face in the same direction.

3.6 Cutting of the seams

To achieve an optimum end result a clear distinction must be made between carpet where the edges of sections can be laid edge to edge, and carpet on which the edges have to be cut.

3.6.1 Backing edges

Backing edges usually are found with woven carpets. These backing edges will first have to be removed by cutting them off with a knife to enable a correct pattern joint to be realised. On deep pile carpets it is recommend to cut these strips off from the back of the carpet.

3.6.2 Butt joining

Proceed as follows for carpet that has to be laid seam to seam. Lay the first section to size and place it along the wall or skirting allowing a slight upward overlap along the length. Lay the other sections next to and overlapping each other, cut the seams, fold half the carpet back and glue them as described in the paragraph 'Adhering'. After rolling press the seams firmly together using a knee stretcher or seam stretcher, and in such a manner that seams close together and the pile stands straight up.

3.6.3 Cutting the sides

On carpet where the sides require cutting go to work as follows: Lay the first section to size and place it along the wall or skirting allowing a slight upward overlap along the length. Lay the second and any other section as required, allowing the edges to overlap by ± 5 cm. Once the carpet sections are lying adjacent to one another check the carpet again thoroughly before gluing. Cut the first half of the longitudinal seam and the following seams to size. Always cut along a steel rule or straight edge. It is recommended that the edges be cut from the back of carpet with a deep pile.

Note: Never cut the carpet that lies in the adhesive. Otherwise adhesive is also removed from a particularly critical adhesive location when the offcut is removed!

3.7 Adhering

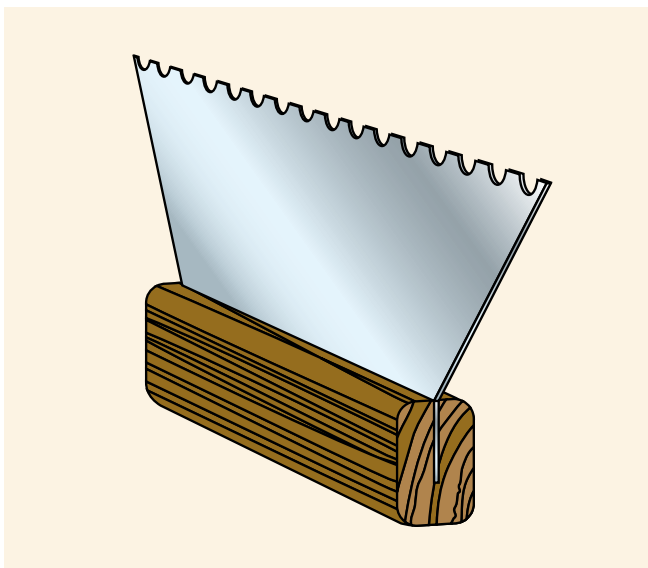

Fold the last section laid back halfway along its length. Make a marking line on the subfloor alongside the last section but one, also lengthwise, and then fold it half back. Repeat the process up to the first section laid. Smear the floor with the recommended adhesive. Work from the centre of a sectional length and start with the last folded section. Spread the adhesive up to approximately 25 cm away from the marking line. Use a notched adhesive spreader. File new notches in the spreader whenever necessary. In general applicable: Notch depth: 2 mm tooth distance 2.4 mm, tooth width 2 mm.

Note: Always read the instructions supplied with the adhesive with respect to the type of adhesive spreader required, the correct type of adhesive and the quantity to be used.

3.8 After application of the adhesive

Once the adhesive has been applied roll the carpet out into the adhesive bed. The carpet can then be rolled with a roller, both across the width and in the length. Proceed in exactly the same manner for the following sections. Never allow adhesive stains to dry, remove them immediately with the solvent recommended by the adhesive supplier. Roll out any blister, bubbles, etc. before the adhesive bonds. It is important not to delay this operation. After that the carpet should be trimmed all around.

Note: Ensure that the pile on the joints is standing straight up and that tufts have not been pinched into the seam. That is achieved by laying the seams of previously adhered sections accurately and pressing them firmly together.

3.9 Stretching carpet onto underlay and spiked strips

Stretching with the carpet gripper method is the oldest used installation technique (although grippers have improved a lot), but can only be used for specific types of floor covering, mainly woven floor covering and carpets with a woven secondary backing. The carpet gripper method has advantages to the other fitting techniques like:

- better walking comfort improved thermal and acoustic isolation
- removal and replacement (eventually : re-use) can easily be done
- lifetime of the floorcovering can be enhanced by using an underlay
- certain preparations for levelling the subfloor usually may be omitted

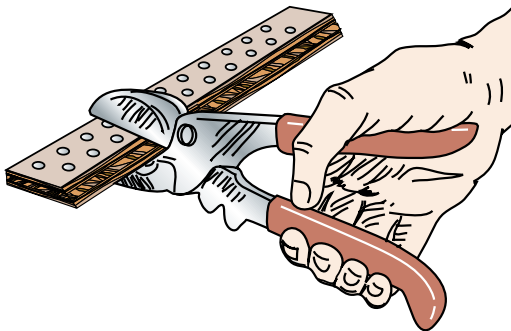
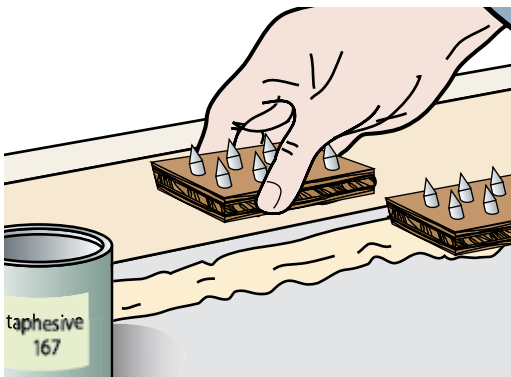
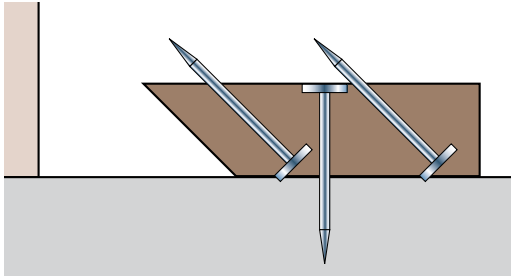

The stretching technique is more time consuming than gluing, due to the preparation required. It may not be seen as a means to hide an imperfect subfloor. Uneven subfloors have to be levelled out to avoid that excessive high spots would show through the carpet. So, treat the subfloor as described in the first part of this chapter. On cement bound floors repair all cracks etc. Treat wooden floors as described in the paragraph 'Wooden Floors'.

For wooden floors use spiked strips fitted with nails and fit them with the spikes facing the skirting board around the entire perimeter of the room. To fit spiked strips to concrete floors use steel nails or adhesive. In the latter case use a neoprene or epoxy adhesive and work following the instructions supplied with the adhesive. Always use an adhesive on hard subfloors or if the subfloor becomes damaged as a result of nailing.

Check this beforehand. If the 'adhesive method' is being used we recommend cutting the spiked strips into lengths of ± 12 to 15 cm to enable a better bearing surface to be created. In this manner material tension along the length of the strips can be avoided.

The same applies when fitting spiked strips around a column or pillar. When applying the stretching method for heavy qualities in large areas, a wide spiked strip or a double row of standard spiked strips is required. The strips should be kept free from the skirting at a distance of $2/3$ the thickness of the carpet to allow sufficient space for finishing. The underlay should be laid within the strips applied, and stapled along the seams and edges on wooden floors. The underlay should however first be stretched slightly and any excess underlay removed. On hard subfloors a small strip of the underlay should be glued along the edges and seams to prevent it from slipping or sliding. The carpet can be rolled out allowing a slight overlap along the skirting. If multiple sections are being laid, once laid out, the seams have to be joined together using seaming tape. Lay the seaming tape underneath the seam and on the underlay. Ensure that the back and pile of the carpet fit together well. Check the temperature

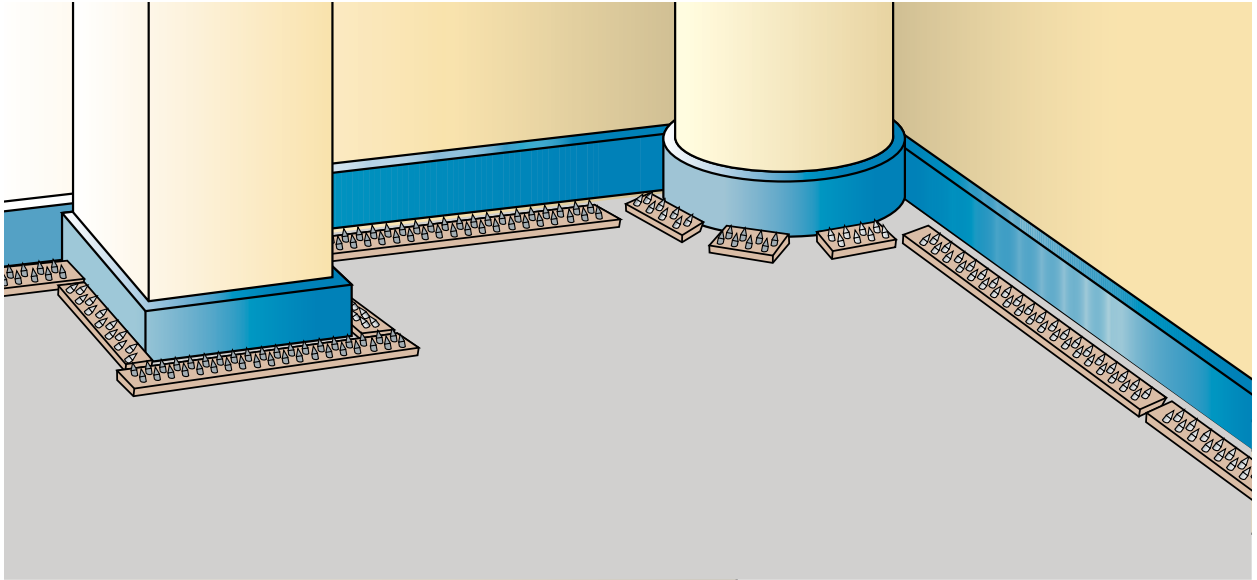

adjustment on the seam welder and position it at the beginning of a seam. The carpet edges should fall on both sides of the seam weld with the handgrip emerging between them. Once the welder begins to glide easily, slide it slowly forwards and press the carpet behind it into the adhesive bed using the flat of the hand. The carpet backs should meet perfectly and the pile should be standing straight up.

Note: Do not exert any pressure with your knees. Allow the seam to cool. Bulging can be prevented by covering the seam with a strip of carpet or hardboard.

Note: Do not apply any pressure on the seams.

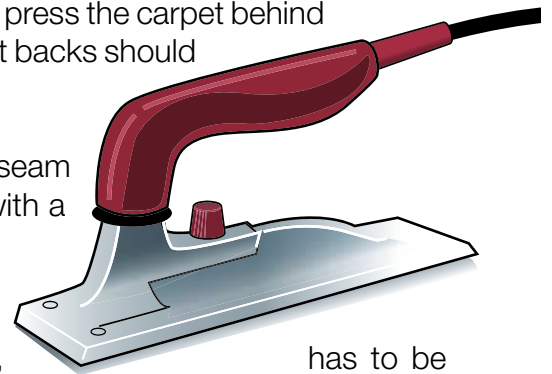

The wall to which the carpet is attached before stretching, has to be chosen in function of the highest tension to be used lengthwise. Begin stretching the carpet from a corner. Stretch the carpet onto the spikes using your knee tensioner and a hammer.

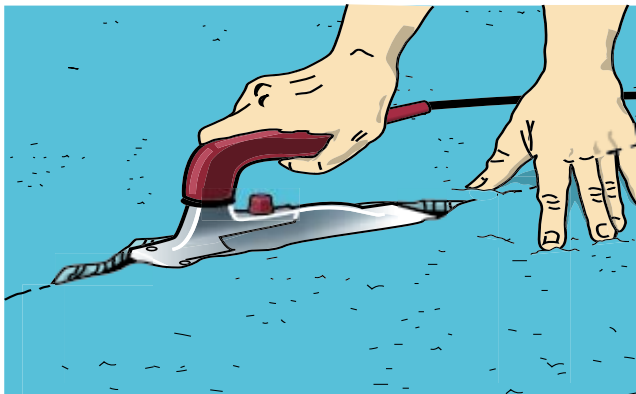

The claws of your knee tensioner should grip into the backing of the carpet. Now use the power stretcher to stretch the carpet fully. Place the tailpiece in the corner in which you started and stretch the carpet towards the opposite corner. Note: Place a piece of carpet between the tailpiece and wall to prevent damage to the wall. Stretch the carpet following the examples and sequences provided.

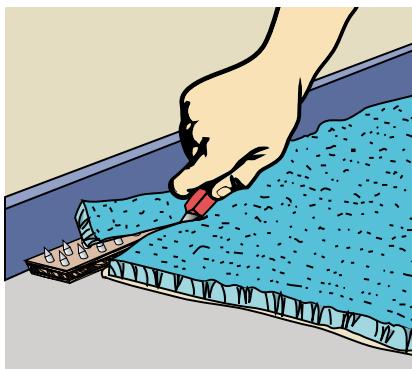

Make sure when stretching that the carpet is free in the length from the starting position towards the wall to which you are working. Be careful of any seams, ensuring they remain straight and parallel to the walls. If possible always stretch away from the

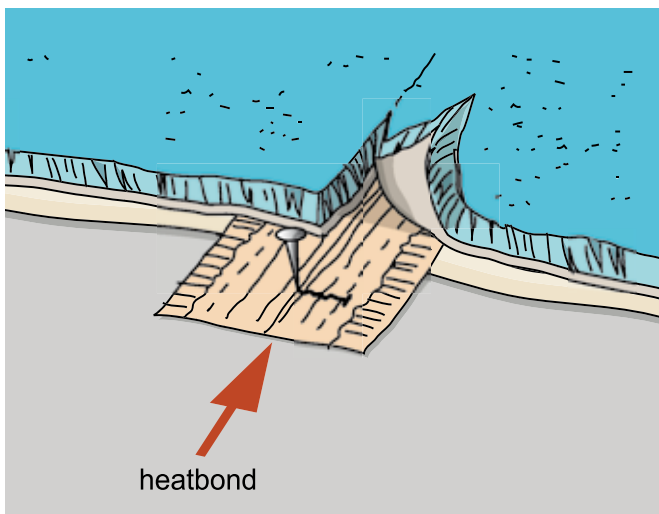
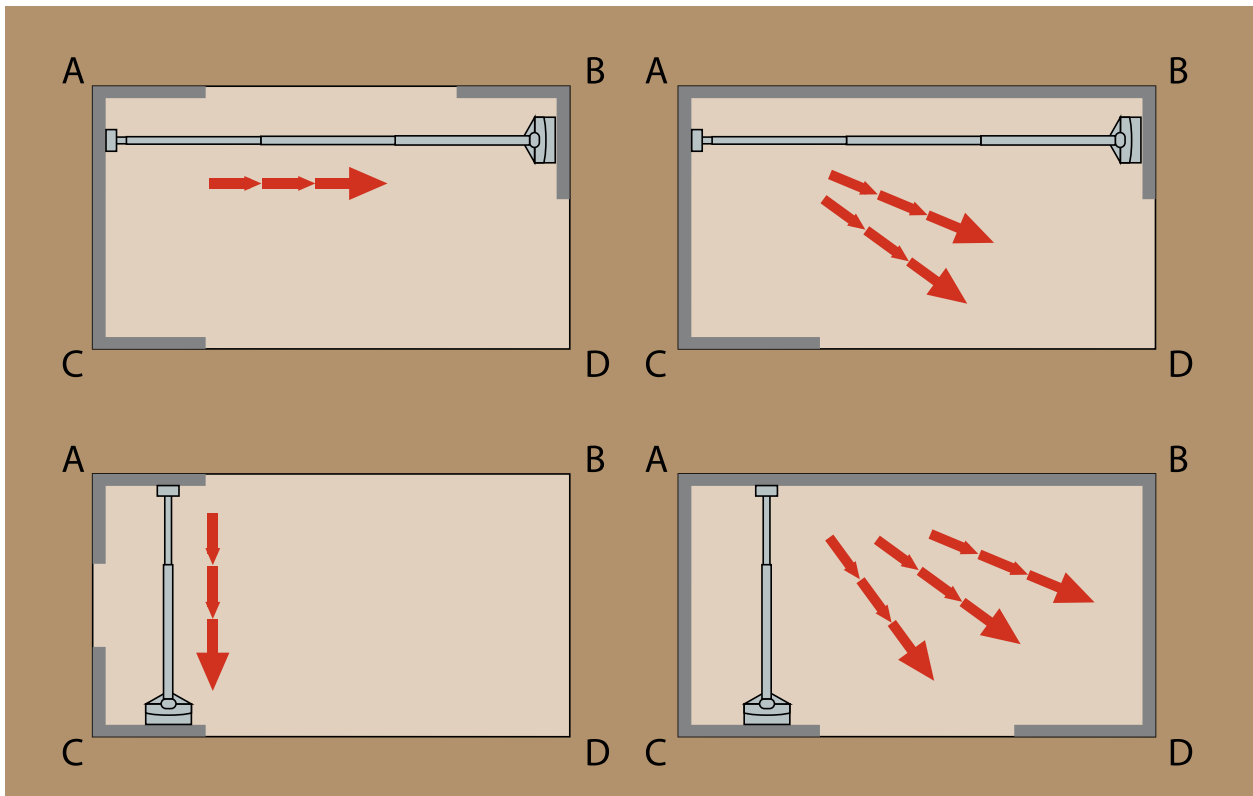

seams and place the head of the power stretcher in the middle of the seam being stretched over its length. Use a palette knife or a special carpet bolster to drive the carpet in behind the spiked strips, so that it hooks onto the strips when the tension being applied is released. After making a full check, cut the carpet and use the carpet bolster to work the carpet in between the spiked strip, wall or skirting. After the carpet has been stretched over the whole room, the edges are trimmed and pushed down into the gap between wall and carpet gripper. Use

strong profiled edging trims on areas where the carpet ends and a different floor surface begins. A profiled edging trim will help prevent damage and unravelled edges.

3.10 Removable installation

The purpose of this type of installation is to leave the subfloor intact after removing the floor covering. The difference with the glued down fitting is the type of adhesive used: a self adhesive membrane or an adhesive that does not produce a permanent bond, the so called 'release type adhesive'.

The preparation of the subfloor, especially cleaning and dusting, is essential for obtaining good results. During removal, the splitting has to occur between glue and carpet backing, and not between primary and secondary backing! In many cases, floor coverings with SBR-foam backing are not resistant to the ammonium substances in the release type adhesive, and should not be used in release systems.

3.11 Pattered carpet

Fitting patterned carpet requires a great deal more attention and time than plain carpet. A good section plan that takes correct matching and pattern repeat length into account is an essential component of fitting patterned carpet.

3.11.1 Pattern shifting (run out)

Slight pattern shifting should always be taken into account. Pattern shifts can not only occur during the production process, but also as a result of shrinkage under changing atmospheric conditions (e.g. during transport). Any pattern shift, however small, will have to be corrected when fitting. The extent to which any pattern shift is visible in practice is greatly dependent on the size of the area, the pattern and the colour, and the corrections required when fitting.

The application of straight stripes across the width of the carpet is not recommended, as even with good correction a slight shift virtually always remains visible. The Desso project group can supply you with supplemental information in this respect.

3.11.2 Pattern shift between pieces from the same production

A pattern shift may occur within one production. Pattern repeat length between ≥ 0 cm and < 10 cm maximum deviation 2% of the pattern repeat. Pattern repeat length between ≥ 10 cm and < 100 cm maximum deviation 1% of the pattern repeat. Pattern repeat length ≥ 100 cm as quoted by manufacturer.

3.11.3 Bowing

Z-bowing is defined as the deviation from squareness. The edges of the strip sections do not

Pattern shift

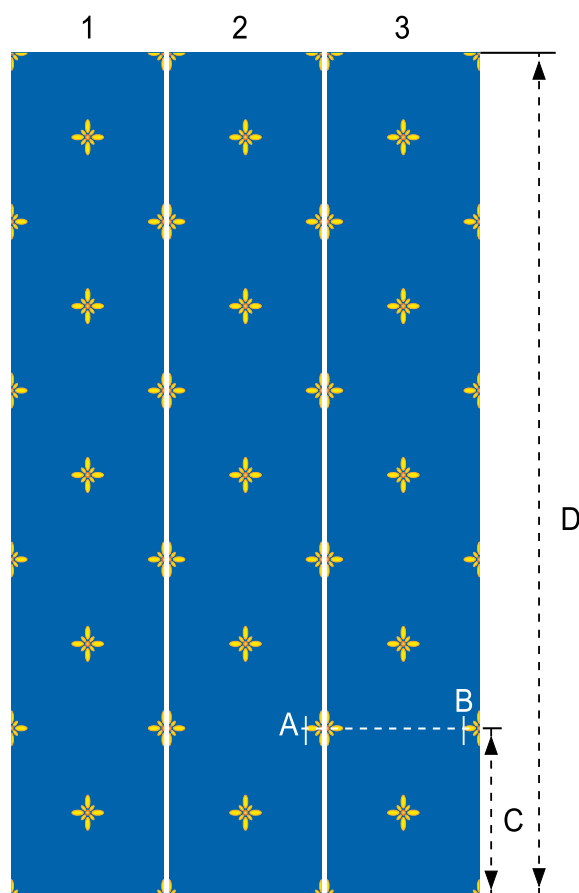

1/2 pattern shift

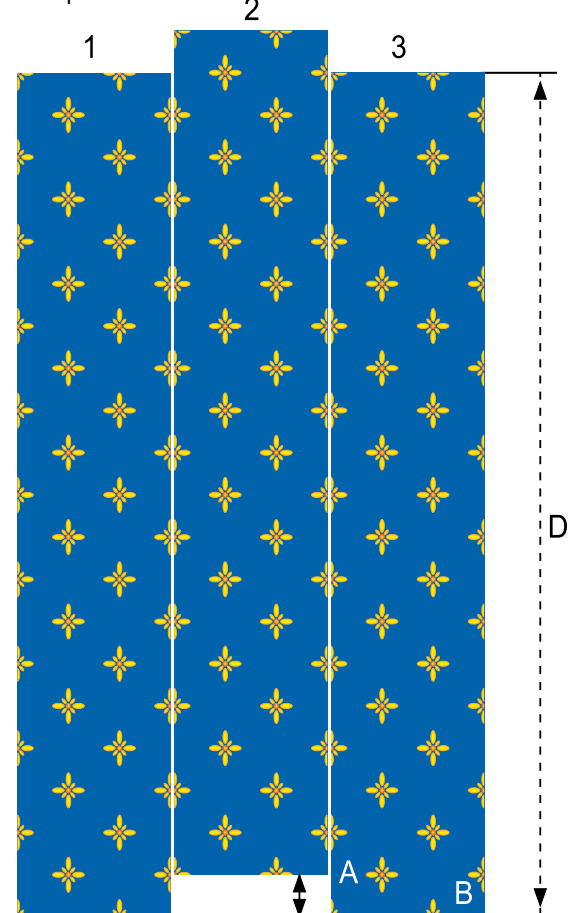

lie in one line. See drawing. In this case a maximum deviation of 4 cm is permitted. S-bowing is defined as the bowing in relation to a straight line on the strip section. A maximum deviation of 4 cm is also applicable in this case.

3.11.4 Measuring up

When multiple sections are being laid together extra metres will always be required when applying a carpet with a pattern, and the undersizes will be distributed over several rolls. Both the pattern repeat length and the pattern repeat width are of importance when calculating

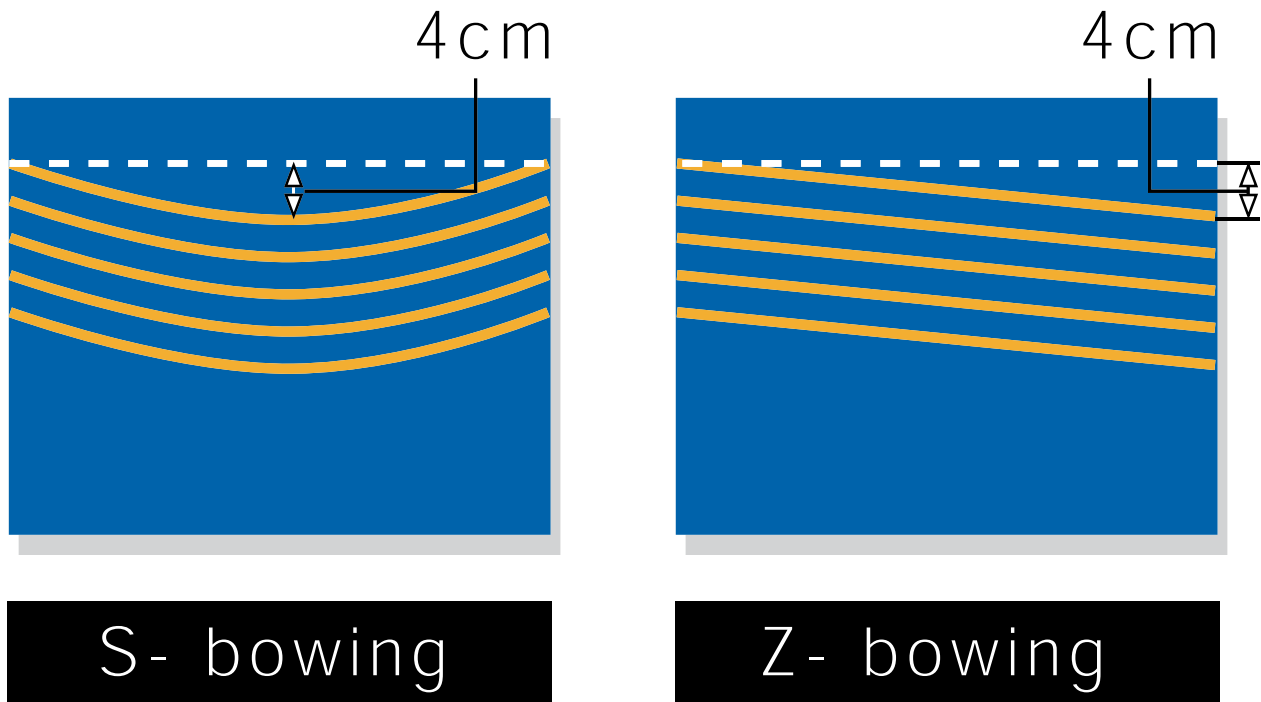

the number of metres required. Information regarding the pattern repeat length and width can be found in the product specifications. Consult the Desso Group or Desso Technical Services if necessary. As a general guideline it applies that: floor length + cutting losses (minimum 10 cm) + one extra repeat length = section length. This length should be stated when ordering. It is the responsibility of the carpet fitter to submit a correct section plan for patterned carpet that takes the above into account.

Note: In certain areas you should also take the repeat width into account for the correct quantity of carpet! In some cases an extra section length may be required.

3.11.5 Laying patterned contract carpets

Lay out the first section fully with an overlap on the skirting or other edges or obstacles. If a long or large repeat has been chosen you will have to take the distribution of the pattern at the beginning and at the end of the section in relation to the walls, doors, etc. into account. The second section can now be laid in such a manner that the seam pattern along the seams of both sections matches. When laying 'on the repeat' you have to begin at the centre and work to the left and to the right. Any pattern or repeat shift in woven carpet can be corrected with the knee stretcher and/or power stretcher. For adhering the carpet please refer to the paragraph 'Adhering', and for seams that do or do not require cutting please refer to the paragraph 'Cutting to size'.

Note: When fitting, first lay out all sections next to one another to ensure correct matching of the pattern. Any possible pattern shift or straightening in relation to walls etc. can then be easily corrected.

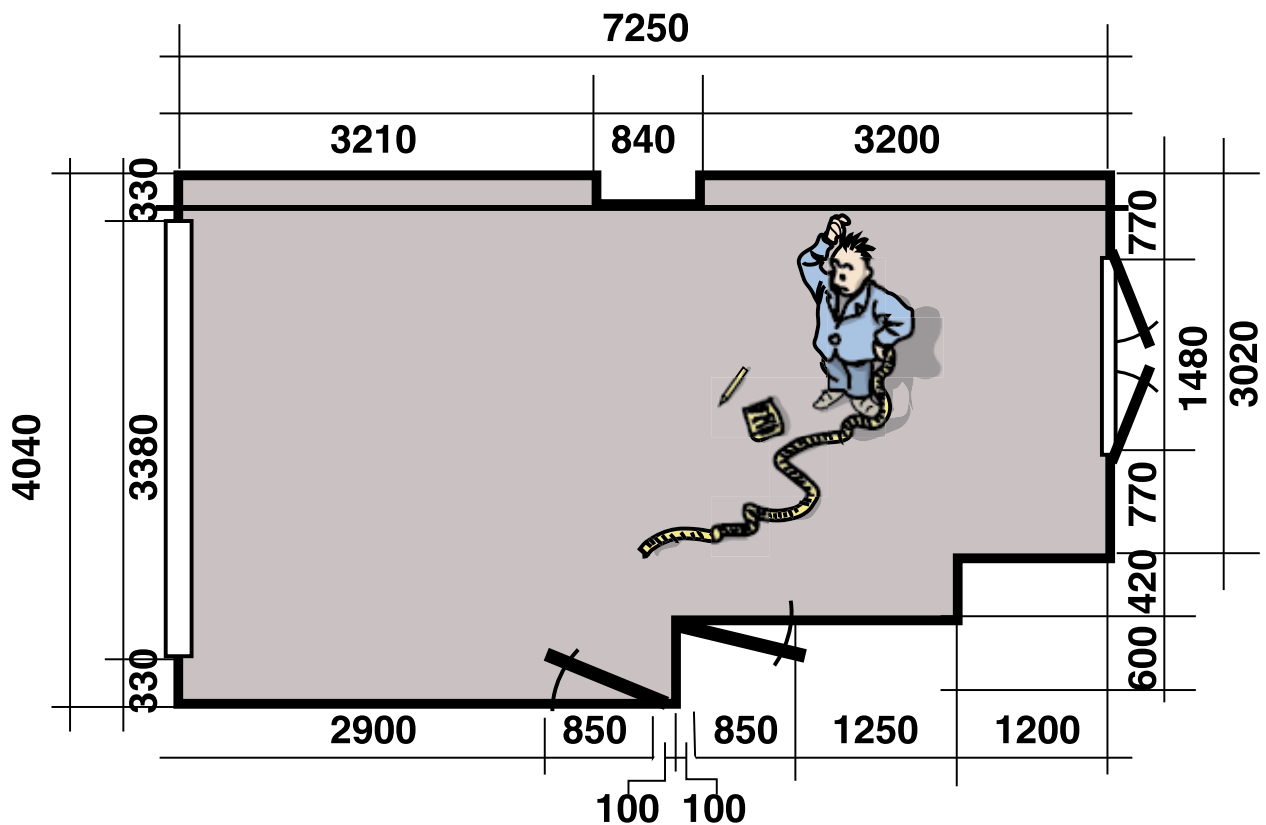

3.12 Wheelchair resistant adhering

The 'wheelchair resistant' qualities must of course also be adhered to the subfloor in an effective 'wheelchair resistant' - manner. A subfloor only qualifies as wheelchair resistant if it complies with a compression resistance of at least 250 kg per cm².

Note that for use on carpets a wheel chair always must be provided with wheels according certain specifications (see the Appendix with International Standards) i.e. 'hard' wheels (type H) with the mandatory measurements: diameter 50 mm and width 20 mm. 'Soft' wheels (type W) of existing chairs therefore have to be replaced.

For the fitting method and quantity of adhesive required please refer to the instructions supplied by the adhesive manufacturer. Always ensure that the notches on the adhesive spreader being used are in good condition!

3.13 Adhering carpet with underfloor heating

The underfloor heating must have been in operation for at least 10 days before the carpet is laid to ensure that any residual moisture has completely evaporated. The carpet can of course be laid loose, but that is not recommended for large areas, as corrugations or shrinkage may occur. If the carpet is being stretched the use of underlay is recommended. When using underlay the heat permeability resistance of the underlay and carpet should be added together. The collective value may not exceed a value of 0.17m²/K/W. When gluing the carpet with a dispersion adhesive the floor temperature may never be any higher than 200 °C. In this connection follow the instructions supplied by the adhesive manufacturer and ensure the adhesive being used is in fact suitable for application on a floor with underfloor heating.

In short the following values are applicable:

- floor temperature
- max. 20°; min. 10 °C.

- room temperature
- max. 25°; min. 15 °C.

- relative humidity
- max. 75%; min. 55%.

After gluing the carpet, the underfloor heating temperature may not be raised for 48 hours. The heating temperature can then be gradually increased up to the normal operating temperature.

3.14 Adhering carpet with low electrical resistance values

In areas that accommodate mainframes and precision electronic equipment, stringent antistatic requirements are applicable. If Desso contract carpet with low electrical resistance values is being fitted it might be necessary to adhere the carpet using a conductive adhesive. In exceptional cases the application of a so-called 'copper band' is recommended. In consideration of the highly demanding conditions in computer centres and similar locations, Desso can also produce contract carpets with a reduced electrical resistance. Several Desso products possess this property as standard. Please refer to the product specifications for the various qualities or consult the Desso project group.

Note: On insulating floors we recommend fitting the subfloor with a conducting copper strip of $\pm 1,25$ m. per 40 m² or per room. This so-called 'copper band' should be well earthed. For further advice please consult the Technical Services Department at Desso.

Fitting Desso carpet on stairs

4.1 General

Fitting carpet to stairs can be divided into three methods of application, namely:

- Covering the stairs with carpet where the treads and the risers are completely covered in carpet and fully glued.
- Covering the stairs with carpet whereby nosing is fitted to the nose of the tread, and the tread and riser are fitted with carpet and fully glued.
- Fitting the stair carpet using the stretching method where the carpet is stretched over the tread and riser without a nosing section being used.

Before any of these methods can be applied it will be necessary to inspect and prepare the stairs following the instructions below. If the carpet is being fitted on stairs without tread nosing, with the tread and riser carpeting fitted without interruption, the rounding at the front or nosing of the tread should have a radius at least 2.5 cm. If a hollow angle is used in the corner between the tread and the riser, the hollow angle should also have a minimum radius of 2.5 cm. If tread nosing is present, the front of the tread should have the same shape as the inside of the nosing section. This is absolutely essential for ensuring a good connection and obtaining firm adhesion of the nosing section on the tread. If any space exists between the nosing section and the tread it is quite likely that cracks will form in the nosing section. The front of the nosing section should not be glued.

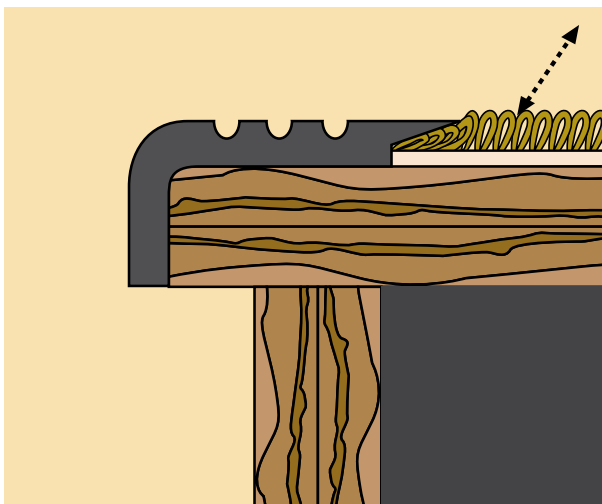

with tread nosing section

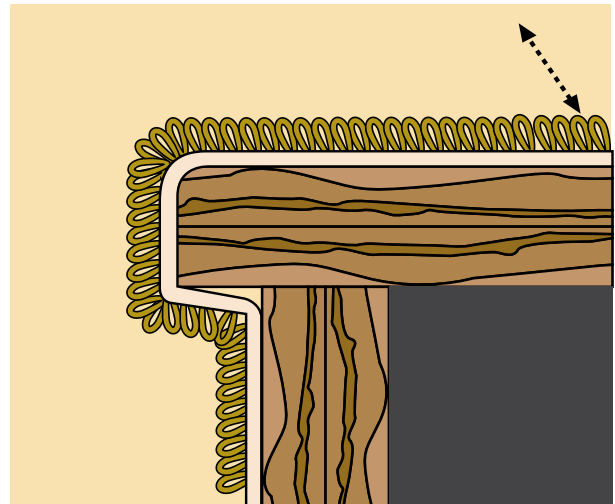

without tread nosing section

4.2 Carpet pile direction

The pile direction of the carpet should always face downwards if no nosing sections are being used. If nosing sections are used the nap or pile direction should face upwards in connection with the attachment of the carpet to the nosing section.

4.3 Old stairs with worn treads

Old stairs on which the treads are considerably worn should first be levelled. This can be achieved by placing a wooden strip across the front of the tread, or if the stairs are to be carpeted without nosing sections, by using a wooden dowel sawn through the middle lengthwise. Use can also be made of the repair strips specifically made for that purpose. Inspect any old coats of paint on the stairs and remove if necessary. If fitting PVC or rubber nosing sections the tread should be made completely free of paint. The neoprene adhesive with which the nosing section is glued will dissolve any old paint remaining, resulting in poor adhesion. Before gluing, old paint should be thoroughly degreased and sanded using coarse sandpaper.

4.4 New wooden stairs

These stairs are usually untreated and do not usually cause problems with adhesives. They should nevertheless be inspected and the rounding of the nosing corrected if necessary. The nosing rounding should have radius of ± 2.5 cm.

4.5 Old hard stone, tiled and concrete stairs

In case the stairs have old coats of wax and suchlike the stairs will require degreasing before proceeding. Any worn treads should be repaired using repair strips and then levelled. Sand if necessary.

4.6 New concrete stairs finished with a cement coating

Repair any existing damage using synthetic mortar, and repair any damage to the nosing of the treads in particular. Level and sand if necessary.

4.7 Adhering carpet on stairs

First cut the treads and risers to size with the aid of a stair spider. Allow an overlap of several centimetres on all sides. Take note of the pile direction. Both water based adhesive or neoprene adhesive can be used for adhering. The risk of blister formation is however greater when using water based adhesive. Neoprene adhesive is therefore preferable when gluing on both sides. Use a well notched adhesive spreader for applying the adhesive to the treads and risers, and follow the instructions supplied with the adhesive.

When using PVC or rubber nosing sections make sure that sufficient adhesive is applied to the lip of the section that is located underneath the carpet on the tread. If adhesive is being used it may be applied using either a fine-toothed spreader or a brush. Do not apply any more adhesive than you can work within the drying time of the adhesive. Work from downstairs up, and ensure that the carpet is well fixed to the nosing on each tread. Cut off the overlap on the tread and riser.

4.8 Carpeting stairs using the stretching method

Fit the spiked strips on the treads and risers. Note: 2/3 of the carpet thickness is the distance between the strip and the riser, tread or stringer. Place the strips along the stair stringer up to ± 2 cm from the nosing. Do not fit strips on the nosing. If the stairs are open on both sides use can be made of an aluminium compression section. Work from downstairs up. On concrete stairs cut the strips into lengths of ± 10 cm and adhere them using epoxy adhesive.

Once the strips have been fixed in position the underlay can be laid and glued into position using a little adhesive. After the carpet has been cut with a slight overlap, and care taken that the pile is laid upright on the nosing with the nap of the carpet going down the stairs, the carpet can be fitted, again working from downstairs up. Hook the carpet onto the spiked strips and work it up over the first tread to the second riser. Affix the carpet to the spiked strips with the aid of a carpet bolster. Make use of a knee kicker to stretch the carpet tightly over the tread and riser. Do not cut the overlap off completely, but drive it in behind the strip with the aid of the carpet bolster. Now finish the sides and follow the same method of working on the remaining trades and risers. The uppermost tread is finished using a special finishing strip. If the carpet is being fitted on a platform or landing, the top riser should also be included and the carpet affixed to it, or secure to the spike strips at the bottom of the topriser.

Fitting Desso carpet tiles

5.1 Preparatory work

Acclimatisation of tiles should take place in conditions as close as possible to those of the building when occupied. Therefore the tiles should be unpacked at least 24 hours prior to installation and allowed to acclimatise at room temperature. The tiles should be installed at a minimum room temperature of 15 °C with a maximum relative humidity of 75%. A floor temperature of at least 10 °C should be maintained. If it is not possible to unpack the tiles fully, open the carton sides to allow air circulation and stack them to a maximum of 8 to 10 boxes high.

5.2 The subfloor

Carpet tiles can be installed on any floor that is smooth, dry, pressure-resistant, clean and protected from damp. Any remnants of previous carpet, felt or underlay must be removed as should any adhesive, dust, grease or polish. Any holes or indentations, joins, cracks or uneven floor areas should be levelled with a good floor filler. Follow the instructions of the manufacturer.

5.2.1 Concrete floors

New concrete must be dry when tested with CM-meter or protimeter: the CM-value may not exceed 3% and the protimeter-value may not exceed 5%. The relative humidity in the room may not be higher than 75%.

5.2.2 Anhydrite floors

The relative humidity in the room may not be more than 75%. Anhydrite floors must be dry. Tested with a CM-meter the value should be no more than 1% and tested with the protimeter the value may not exceed 2%.

5.2.3 Wooden floors

All loose parts must be removed and the surfaces must be levelled. Wooden floors in a poor condition should be re-surfaced using plywood or hardboard sheets. Hardboard sheets (always install rough side up) should be fastened at 15 cm (6") centres, i.e. 15 cm (6") apart, using a spot nailer/stapler. The same method can be used for plywood up to 6 mm thick. Plywood over 6 mm thick should be screwed to the floor at ± 23 cm (9") centres, i.e. ± 23 cm (9") apart. The same goes for chipboard and MDF.

5.2.4 Dusty floors

Dusty surfaces should receive a sealer treatment with a primer and this must be allowed to dry before the application of the recommended tackifier system.

5.2.5 Others floors

Vanished and polished surfaces should be degreased and then roughened by light sanding.

Note: For floors not mentioned refer to the relevant paragraphs in the section Preparing the subfloors for Desso Contract carpet.

5.3 Important considerations concerning the floor

- All floors should be dry, clean, solid and resistant to compression
- Never install tiles on a sub-carpet or on an existing carpet
- On all floors use 100% anti-slip
- Make sure the anti-slip is well dried before installing the tiles
- When using tape, apply the tape diagonal to the walking direction. If possible, every 2nd row, according to the kind of use and the demands made.
- On computer floors always use conducting anti-slip, so the static electrical personcharge can be led away horizontally/vertically. If necessary lay within every room till max 40 m² a copper band of 1.25 m. transversely underneath the carpet tiles and make sure the copper band is well earthed. In larger rooms use a 1.25 m. copper band for every 40 m².

5.4 Recommendation

Carpet tiles do not require the use of a permanent bond adhesive, gripper or underlay. We recommend the use of an approved tackifier system or anti-slip (which is applied to the whole of the surface area, especially underneath all seams; see the illustration.) Once the tackifier has been allowed to dry the carpet tiles can be placed in position with a hand or knee stretcher. Small areas and individual offices less than 20 m² can be laid with the use of double sided tape underneath all the seams. Consult Desso Technical Services about this. Particular attention should be paid to cut tiles forming the perimeter of the area and also to doorways where partial tiles may also feature.

Note: All cut and end tiles should be laid tightly fitting cq fitting to the wall.

5.5 Guarantee

The installer should notify the manufacturer of any defective material before proceeding with the installation. The manufacturer will be responsible, within the scope of the product guarantees for any defective materials. This refers to material defects identified prior to or during the installation. Desso will not be responsible for poor workmanship or problems due to improper installation (see the Appendix with Terms and Conditions).

5.6 Protection during and after installation

Until the area being tiled is completed with all perimeter tiles adhered in position, there should be no walking on, or movement of heavy furniture over the partly completed installation. Once the installation has been completed the surface should be protected particularly if the area is to be used by other trades during final finishing. If heavy use is anticipated prior to occupation, the area should be protected with hardboard suitably taped at the joins and also a flexible sheet material which will prevent the ingress of dust.

5.7 Laying Desso carpet tiles

Never start installing carpet tiles against a wall. Always start from a calculated point in the room along a perpendicular line or chalk line. In offices start with the corridor and install the rooms afterwards, in order to obtain a good connection. Apply a recommended tackifier to an area convenient in size and once the tackifier has become completely dry, the carpet tiles can be installed in accordance with the illustration. The tiles should be firmly fitted together with a hand stretcher. Be sure that the underbackings are closely together to limit the appearance of joints to a minimum. Care should be taken with cut pile products to avoid trapping edge tufts between the tile joints. The use of hand-knicker ensures that the tiles be butted firmly together: joints will be less visible that way.

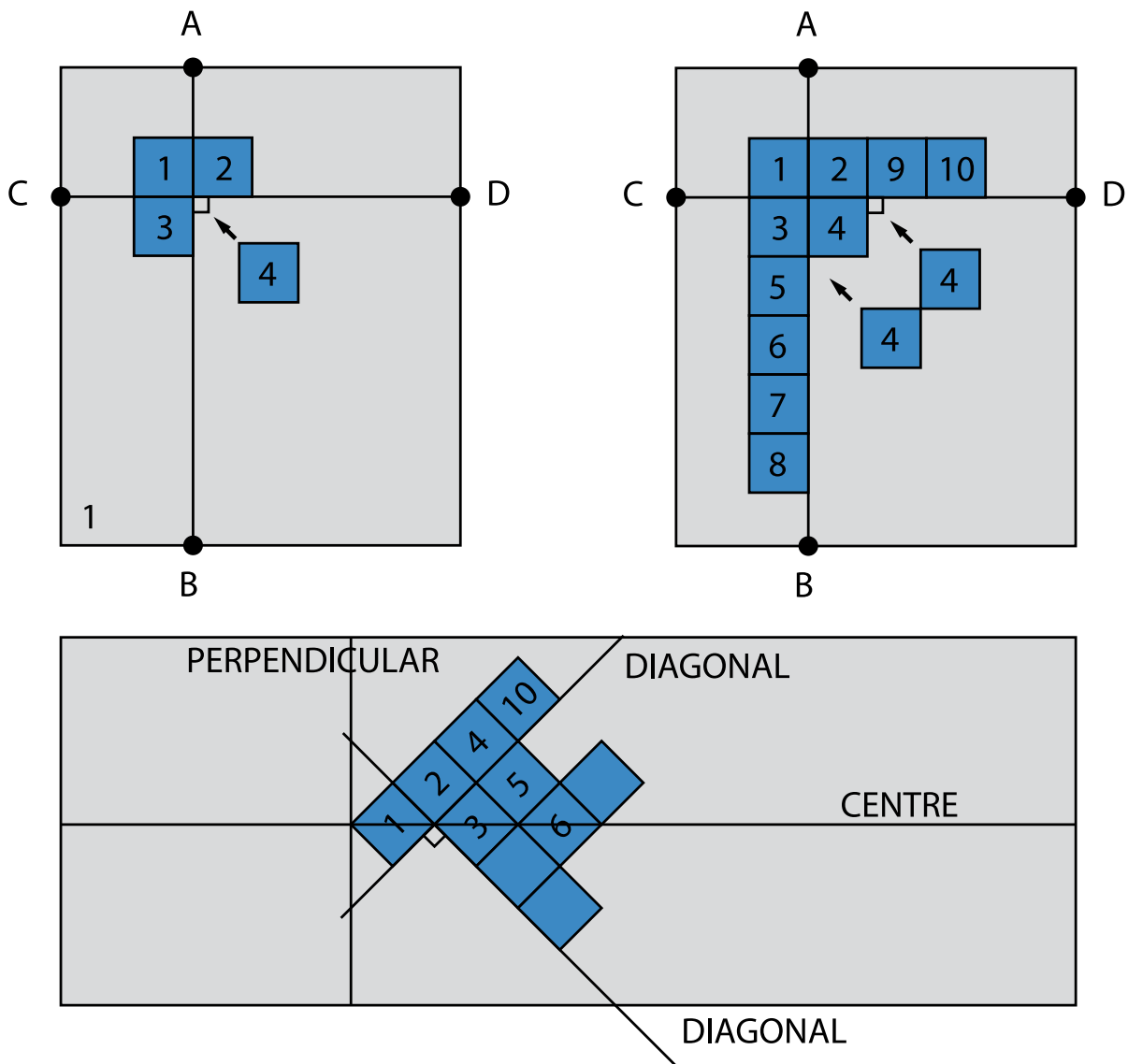

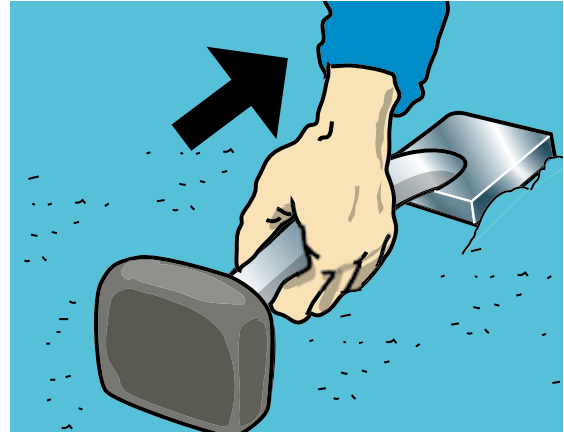
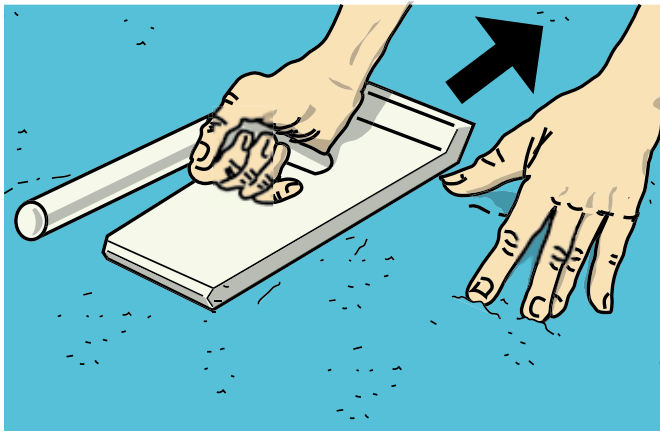

5.7.1 Cutting to skirting boards

To ensure a good fit to skirting boards cut the tile using the methods shown in the diagram, and place the cut edge against the skirting board. When calculating the starting point, check to ensure that tiles can be installed without the need for narrow cuts, minimum 10 cm. It may therefore be necessary to adjust the starting point.

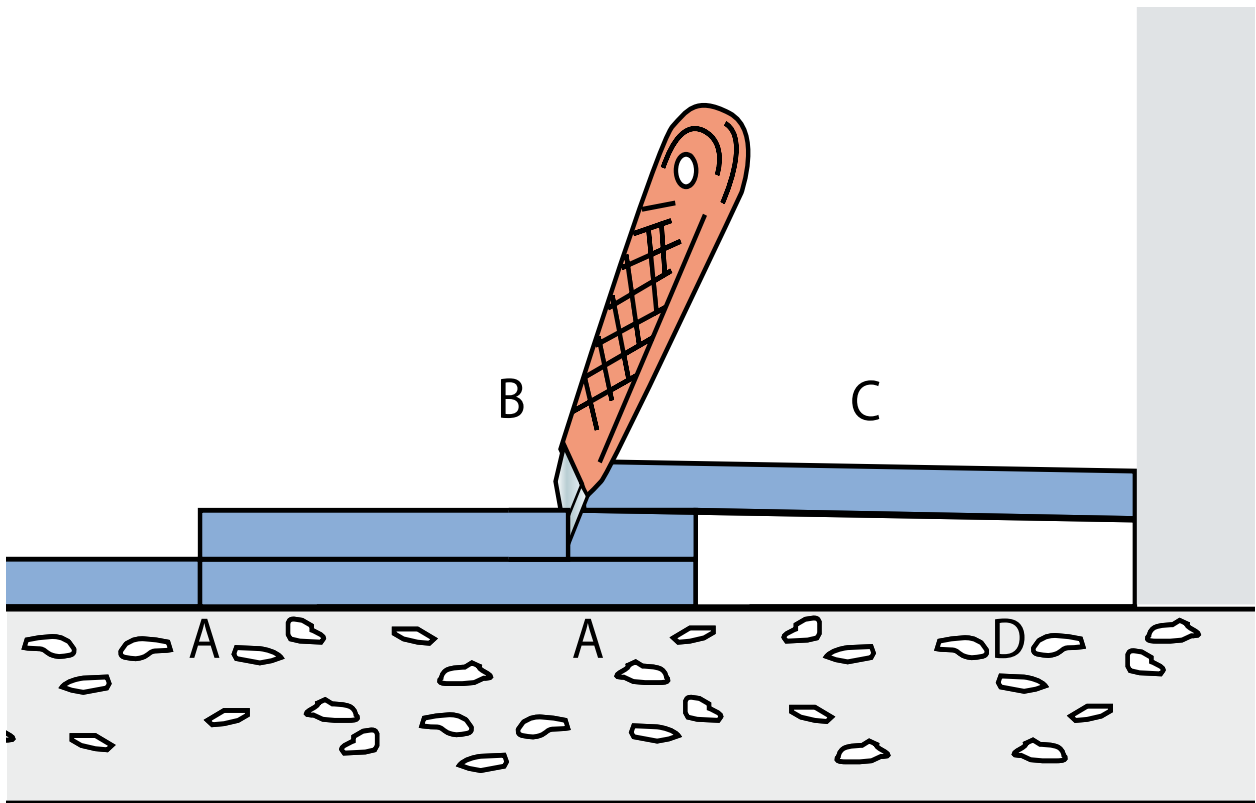

5.7.2 Effects

The majority of carpet tiles may be installed to give four different appearances as shown in the diagram; arrows on the back of the tiles indicate lengthwise. On the samplecards and on the tile boxes you find the useable possibility for each type of tile.

5.7.2.1 Quarter-turn appearance

For this effect the tiles should be installed with the pile direction at right angles to the adjacent tile. This type of installation may be necessary for carpet tiles with a short (loop) pile and needle felt or fiber bonded tiles. This type of installation should not be used with cut pile products.

5.7.2.2 Monolithic appearance

Tiles should be installed with the arrows on each tile pointing in the same direction. This type of installation is necessary for most cut and loop pile tiles and for printed qualities. Install the tiles as much as possible traverse to the light or with the arrows in the traffic direction of the room.

5.7.2.3 Brick wise appearance

Tiles should be installed with the arrows on each tile pointing in the same direction, but started at the half of the width of the adjacent tile. This type of installation may be necessary for carpet tiles with a structural design

5.7.2.4 Ashlar appearance

Tiles should be installed with the arrows on each tile pointing in the same direction, but started at the half of the length of the adjacent tile. This type of installation may be necessary for some loop pile carpet tiles.

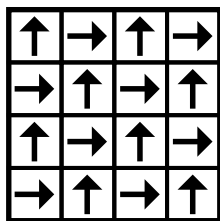

checkerboard

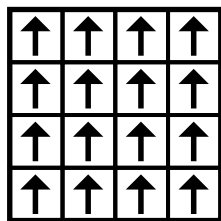

monolithic

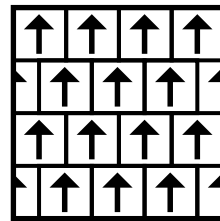

brick

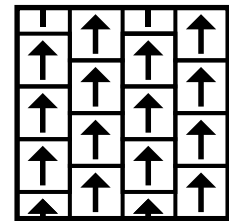

ashlar

5.7.3 Raised flooring systems

Raised access flooring systems are normally 600 mm panels. Desso is able to supply carpet tiles in the 500 mm format and certain products can be made available in 600 mm. The installation technique will vary dependent on whether 500 mm tiles are laid conventionally as with a normal floor or whether a 600 mm tile is placed over the access floor panels. Either size of carpet tile can be installed over a raised access flooring system using a recommended tackifier. The tackifier should be applied with a roller and care should be taken to ensure that the tackifier stops before the edge of the raised panels. This enables panels to be lifted freely as and when the need arises.

5.7.4 Underfloor heating

Carpet tiles can be installed on floors with underfloor heating, providing the floor surface temperature does not exceed 28 °C. The heating should be reduced at least 48 hours prior to installation. Only 48 hours after installation the heating system slowly may be turned up to the maximum of 28 °C.

5.7.5 Castor chairs

In areas where office furniture has castor wheels it is imperative that the tiles are installed on an all over tackifier system. To prevent damage occurring to the tiles, the castor wheel should have a minimum diameter of 50 mm and be at least 20 mm wide.

5.7.6 Stairs

Carpet tiles are suitable for installation on stairs, if fitted with nosings. The tiles and sections of tiles must be secured with a tackifier system on the treads. The risers can be secured with

either a single coat of tackifier applied to the riser or with a second coat applied to the back of the tile which, when allowed to dry, will act like a contact adhesive.

5.7.7 Skirting board

When carpet tiles are used in the vertical plane as a skirting board, the application may need to be approved by a local fire officer.

Needle felt (patterned) carpet

6.1 Influential factors of contract environment

The properties of needle felt carpets are - like with any other textile floor covering influenced by factors of the environment, such as temperature and humidity. These have to be taken into account during the installation process. Before the installation the needle felt carpet has to be stored in a dry and warm room. It is recommended to let the carpet acclimatize in the room at least 1 hour, but preferably 24 hours.

6.2 Subfloor

When installing needle felt carpets the conditions of the subfloor should be the same as with other textile floor coverings, such as broadloom and carpet tiles. This means that the subfloor has to be even, sturdy, free of cracks and dry. Dense surfaces, like for instance PVC, have to be made a little bit absorbing according to the applicable norms (see the appendix). In situations with a floor heating system the temperature has to be reduced before installation, in the same manner as described in the chapters about broadloom carpets and carpet tiles. After the installation the temperature has to be gradually turned up. For floors with old adhesive see the referring paragraphs in second chapter.

6.3 Cutting

Cutting of needle felt carpets should take place before adhering. The carpet has to be rolled out with an overlap of 3 to 5 cm. Next one has to cut the seams in one movement along a steel ruler with a sharp 'hooked' knife.

Note: Laying the original edges of the carpet against one another is not a professional installation method!

6.4 Special requirements with patterned needle felt

It is inherent to patterned needle felt qualities that there is a chance of line marking on the seams. This is dependent of the design and the colour. For optimum results the following is absolutely necessary:

- dense, absolutely straight seams
- usage of seam clasps or a kicker with double head until the glue has dried
- environmental conditions should be as specified in the norm VOB DIN 18365 (see the Appendix with international norms)
- Butt joining for an optimized over-all floor appearance.

6.5 Adhering

The temperature of the subfloor is not allowed to drop below 15 °C, while the relative humidity may not be more than 75% (50 to 60% RH is ideal). The carpet should be adhered preferably with a fast drying and hardening dispersion glue, using a notched adhesive spreader with a notch depth of 2.7 mm and a tooth width of 2.9 mm. When all is cut and tightly fitting and the seams have been completely closed by use of seam clips, the whole floor should be thoroughly rolled with a roller after about 20 minutes, depending on the instructions of the tackifier manufacturer

Note: Thoroughly rolling the seams is especially of the utmost importance!