

LANGFULTON

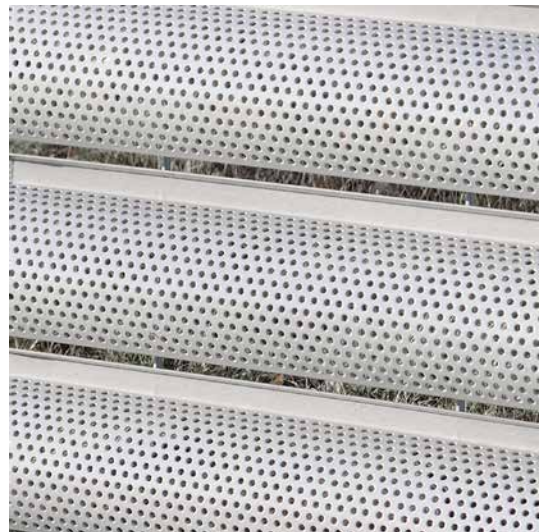
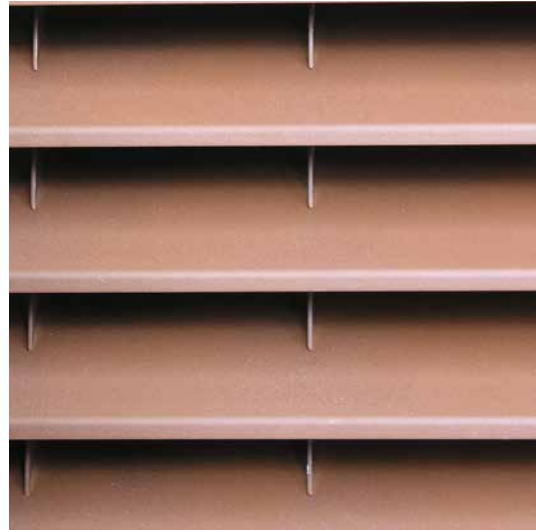

Wall Cladding Systems Specialist Steel Louvres

DeltaMax | Corona | CoronaBrise

t: 0131 441 1255

sales@langandfulton.co.uk

www.langandfulton.co.uk



A louvred facade is an economical wall cladding which combines an aesthetic appearance with a range of functionality

- Visual screening
- Natural ventilation
- Natural daylight
- Weather resistance
- Diffusion of bright internal lights e.g. car headlamps

Advantages of Mild Steel (S235JR)

- Price - mild steel louvres are less expensive than aluminium.
- Cost Effective - all mild steel louvred products are delivered to site as fully finished panels for the most efficient handling and reduced costs.
- Strength - mild steel louvres are much more robust than aluminium. This is particularly important as the linear nature of a louvred material will highlight any distortion. Compound or street-front wall cladding can be subjected to hard knocks; where aluminium may dent or distort, steel will maintain the uniformity of its line.
- Sustainability - steel is a sustainable material with 100% recyclability. The overall average end-of-life recovery rate for steel from construction is 94% in the UK.



DeltaMax, Corona and CoronaBrise are new louvred products. The exceptional size of the louvres make them particularly suitable for larger scale projects; with excellent anti-climb properties for wall cladding.

Alternative applications:

- to conceal an underlying surface
- to ventilate a structural opening, with concealed ancillary steelwork
- to provide a self-supporting panel/post system of visual screening

Lang+Fulton work closely with the architect from concept to completion, preparing CAD drawings, advising on support steelwork and alternative fixing methods.



DeltaMax

DeltaMax is made from inclined steel flat bars with a profiled nosing which are pressure locked to vertical transverse bars. The deep louvre has a bold appearance and the manufacturing process creates perfectly formed intersections for a crisp aesthetic.

All panels are made to custom sizes, with the economy of little or no wastage, and framed with a flat bar.

Intermediate panels are made without the top and bottom framing bar - this achieves a seamless appearance when panels are stacked.

DeltaMax is a particularly robust product made from 2mm thick steel and a 50x4mm framing bar. This provides considerable intrinsic strength for protection from dents or distortion.



Louvre Blade: 110x2mm
Vertical Transverse Bar: 40x2mm
Framing Bar: 50x4mm

Max Panel Size: 2000x2000mm

If a panel is required to be made to a height greater than 2000mm, the width has to be correspondingly reduced.

Fixing Method: panels are bolted through framing bars to steel mullions or T-brackets.

Material: mild steel (S235JR), Corten, stainless steel, aluminium

Finishing: mild steel is hot-dip galvanized to BS EN ISO 1461 with an optional polyester coating in any RAL colour for maximum durability.

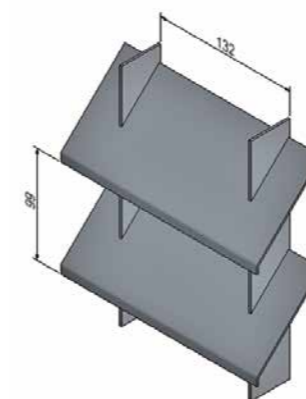

DeltaMax-75

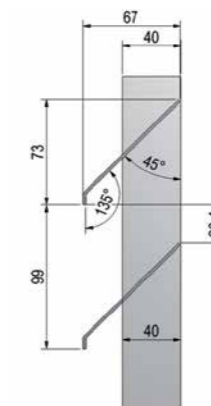

DeltaMax-75

Weight (galvanized): 21kg/m²

PRODUCT	MESH (mm)	SCREENING	FREE AREA
DeltaMax-100	132x66	100%	55%
DeltaMax-75	132x99	75%	60%

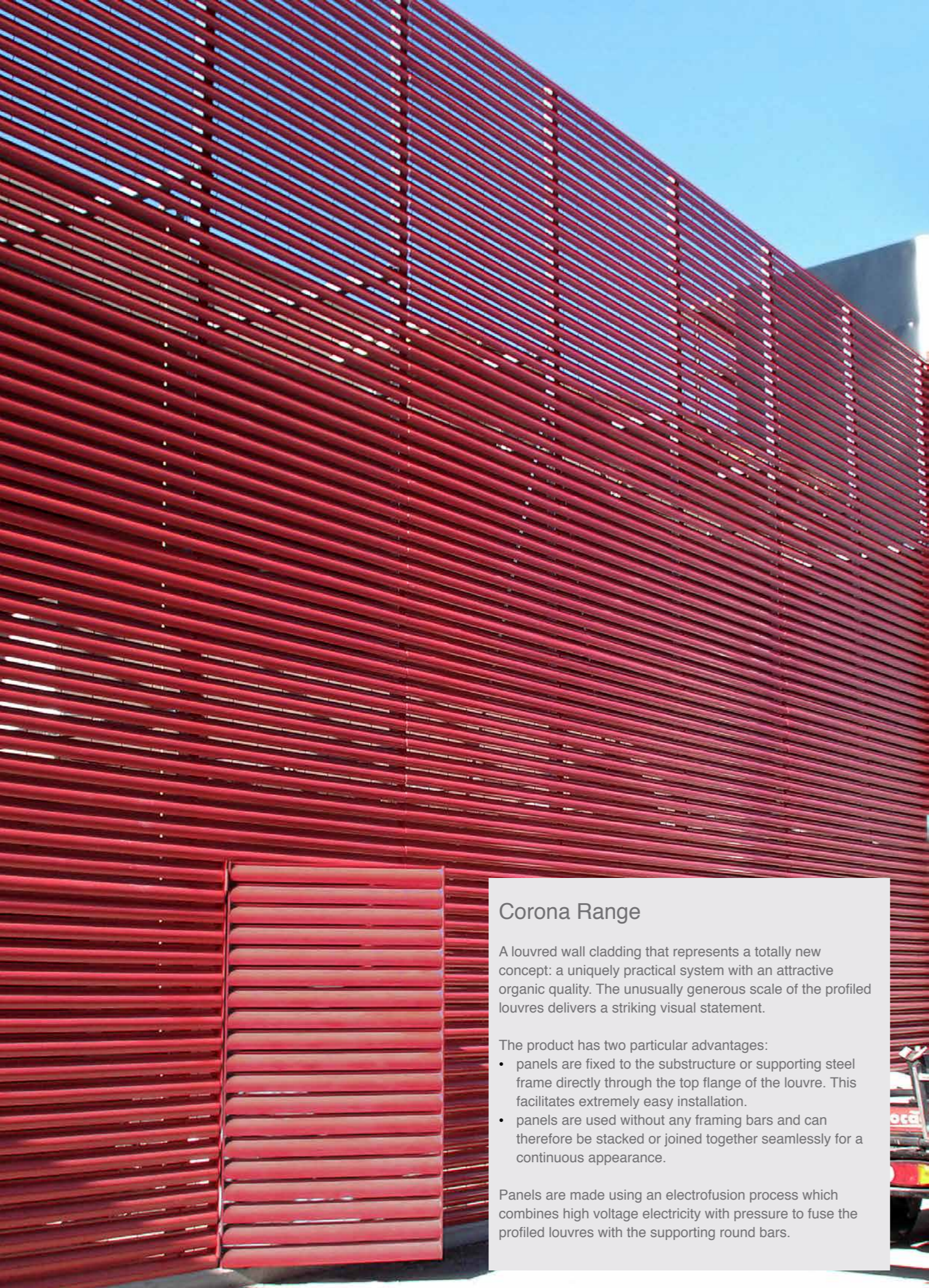

Corona Range

A louvred wall cladding that represents a totally new concept: a uniquely practical system with an attractive organic quality. The unusually generous scale of the profiled louvres delivers a striking visual statement.

The product has two particular advantages:

- panels are fixed to the substructure or supporting steel frame directly through the top flange of the louvre. This facilitates extremely easy installation.
- panels are used without any framing bars and can therefore be stacked or joined together seamlessly for a continuous appearance.

Panels are made using an electrofusion process which combines high voltage electricity with pressure to fuse the profiled louvres with the supporting round bars.

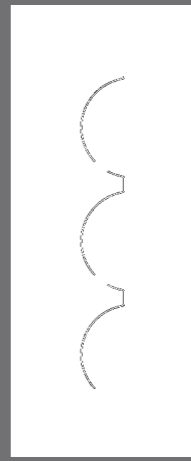

Corona
 Louvre Centres: 116.5mm
 Louvre Depth: 45mm
 Gap between Louvres: 9mm
 Visual Screening: 92%
 Steel Gauge: 1.5mm thick

Material: mild steel (S235JR)
 Finishing: hot-dip galvanized with optional polyester coating in any RAL colour



CoronaBrise

CoronaBrise has the same profile as Corona but has small perforations to allow for increased levels of daylight.

Hole Diameter: 4mm
 Pitch Dimension: 8mm centre/centre
 Pitch Configuration: 60 degrees staggered
 Bridge: 4mm

Free Area of Perforated Surface: 22.7%

Material: zinc coated steel BS EN 10327
 Finishing: polyester powder coated

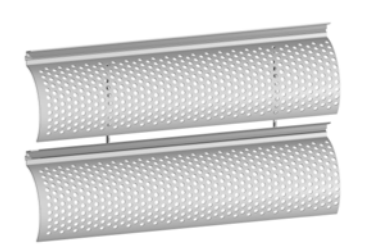
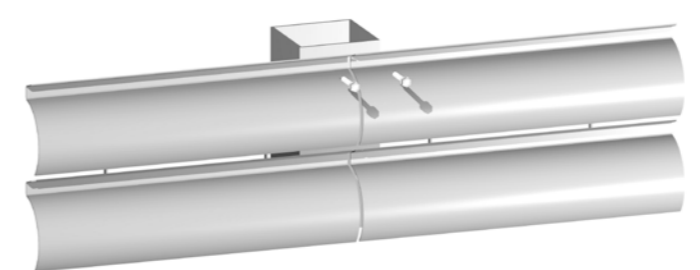

Fixing: recommended at intervals of 500mm on vertical supports
 Self-tapping screws: TE 5.5x45

PRODUCT	MESH (mm)	HEIGHT x WIDTH	WEIGHT kg/m ²
Corona	116x200	1972 x 1800	17.2
CoronaBrise	116x200	1972 x 1800	15.1



LANG+FULTON

Lang & Fulton Ltd, Newbridge Industrial Estate, Newbridge, Edinburgh EH28 8PJ
t: 0131 441 1255 sales@langandfulton.co.uk www.langandfulton.co.uk

Stockholding Depot: Cygnus Point, Black Country New Road, West Bromwich B70 0BD