

**WHERE EXCELLENCE
IS TRADITION**

HERAS[®]
U.K. FENCING SYSTEMS

Leading UK manufacturer of fencing and gates

Zenith System

Security Mesh Fence

Secured by Design



Police Preferred Specification

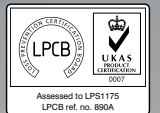

Let us inspire you
www.heras.co.uk

Zenith Security Mesh Fence

Zenith mesh fencing system is approved with Secured by Design as an effective form of crime prevention.

Security

The Heras Zenith security welded mesh system is designed to achieve the highest level of security, providing peace of mind to the end user. Whether the requirement is for general or high security this system fits the bill.

The Zenith mesh panels provide a high degree of security, whilst giving a discreet visual impact on the environment. The mesh apertures provide see through visibility but ensure that the fence is difficult to climb as there are no finger or toe holds and is also extremely difficult to cut.

General Security

Available from 1.8mtr to 2.4mtr high, with typical applications including factories, commercial properties, schools, railways and hospitals. It is possible to achieve high levels of security using this system without giving an intimidating appearance.

High Security

Available from 3.0mtr high to 5.2mtr high, typical applications including airports, railways, ports, utilities and sensitive sites such as research centres, and oil and gas terminals.

These systems can be enhanced in terms of security, by adding a razor tape topping, either single strands, or concertina, or both.

FENCE HEIGHT	POST SPECIFICATION	POST FIXINGS	SYSTEM REF NO.
1.8mtr	SHS 60mm X 60mm	40mm x 5mm Flatbar holed at 295mm c/c	HZGS18
2.0mtr	SHS 60mm X 60mm	40mm x 5mm Flatbar holed at 280mm c/c	HZGS20
2.4mtr	SHS 60mm X 60mm	40mm x 5mm Flatbar holed at 295mm c/c	HZGS24

FENCE HEIGHT	POST SPECIFICATION	POST FIXINGS	SYSTEM REF NO.
3.0mtr	RHS 80mm X 40mm	40mm x 5mm Flatbar holed at 295mm c/c	HZHS30
4.2mtr	RHS 80mm X 80mm	40mm x 5mm Flatbar holed at 295mm c/c	HZHS42
5.2mtr	RHS 100mm X 100mm	40mm x 8mm Flatbar holed at 300mm c/c	HZHS52

Specification

Mesh panels are manufactured from 4mm dia. wire, resistance welded to form a mesh profile of 76.2mm (3.0inches) x 12.7mm (0.5inch). Generally panel widths are 2515mm to suit 2440mm post centres. The panels are overlapped on each post, and secured using clamp bars.

Post Details

The posts used are hollow section steel and the mesh is attached to the face of the post by a flat bar with M8 bolts, standard nut and washer (bolt ends should be burred over).

If corner posts are required, there are two options, internal and external, please see detailed drawing below.

Security Options

Vertical, cranked, T and Y extensions are available for all heights, which are ideal if that extra deterrent is required.

B.T.C ENTANGLEMENT – Concertina coils are available either galvanised or stainless steel finish with coil sizes of 710mm or 965mm diameter.

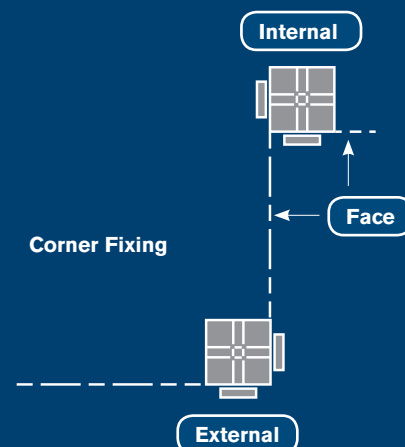
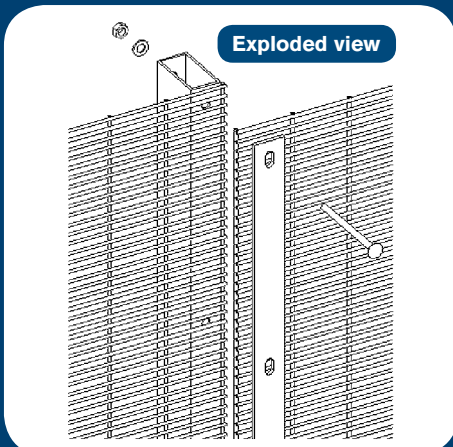

Finish

Galvanised and polyester coated as standard. Other finishes are available upon request.

Connect with us



 **READY FOR YOUR CALL 01302 364 551**

Standard Swing Gate Sizes and Opening to Suit the Zenith System

GATE WIDTH	LEAF TYPE	90° OPENING		180° OPENING	
		BETWEEN POSTS	OVERALL POSTS	BETWEEN POSTS	OVERALL POSTS
1200mm	S/L	1265mm	1425mm	1205mm	1365mm
3000mm	D/L	3120mm	3280mm	3000mm	3160mm
4000mm	D/L	4120mm	4320mm	4000mm	4200mm
5000mm	D/L	5120mm	5420mm	5000mm	5300mm
6000mm	D/L	6150mm	6420mm	6000mm	6300mm
7000mm	D/L	7150mm	7510mm	7020mm	7380mm
8000mm	D/L	8150mm	8510mm	8020mm	8380mm
9000mm	D/L	9150mm	9550mm	9020mm	9420mm
10000mm	D/L	10150mm	10550mm	10020mm	10420mm



Gate Heights Available

Gates to match the Zenith system at 1.8mtr to 2.4mtr high are supplied as per our swing gate range (please see our swing gate brochure for further details). Single leaf gates to suit 3.0mtr high fence are supplied at 2.0mtr high with a lintel. Double leaf gates to suit 3.0mtr high fence are supplied at 3.0mtr high, whereas the gates for 4.2mtr high and 5.2mtr high fences take a 3.0mtr high gate with a lintel. (Full height gates can be quoted on request).

As well as swing gates Heras also supplies a range of cantilever and tracked sliding gates. Full specification details and drawings are available on request, please contact our sales office for more information.

Maximum Security Specification

This is essentially the specification used for prisons and other high security institutions.

FENCE HEIGHT	MESH PANEL	POST SPECIFICATION	POST FIXINGS	SYSTEM REF NO.
5.2mtr	5200mm x 2515mm	Hot rolled CHS 139.7mm x 6.3mm x 6125mm with welded cap	40mm x 8mm Flatbars holed at 152mm c/c c/w M10 bolts and nuts	HZMS52

Typical Fixing Detail - Maximum Security

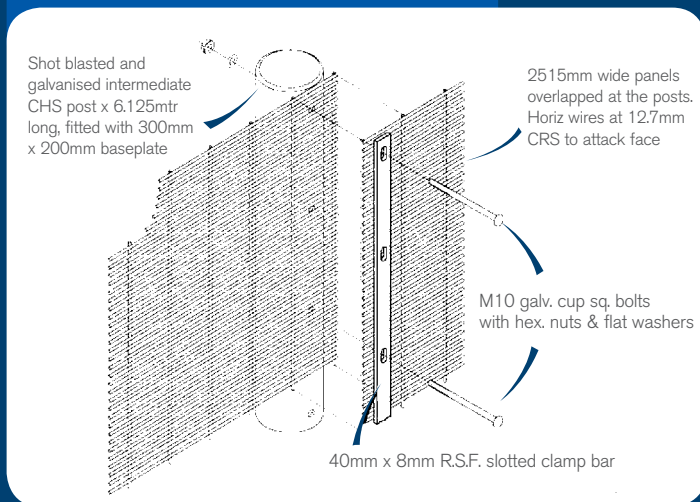

Plan of 90° External Corner

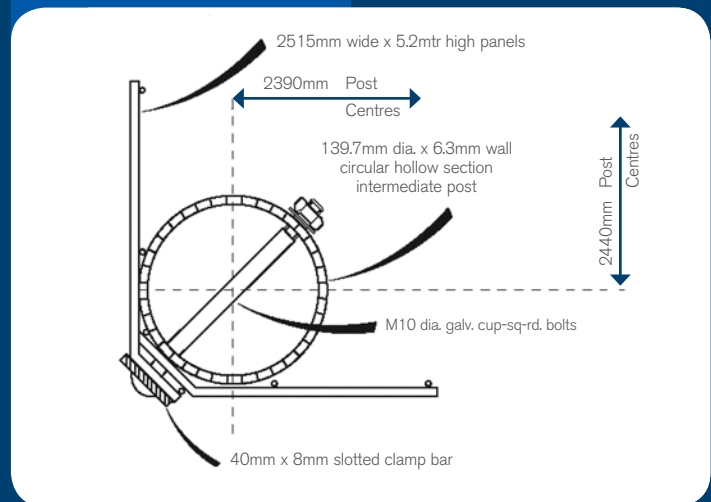

Secured by Design



Approved Product

'Secured by Design' is the UK Police Flagship Initiative supporting the principles of 'designing out crime' by use of effective crime prevention. Fencing Systems marked with the SBD logo have been independently tested and approved to SBD standards.



**WHERE EXCELLENCE
IS TRADITION**

Leading UK manufacturer of fencing and gates

Heras Way, Off Carr Hill, Doncaster, South Yorkshire, England, DN4 8WA

Tel: 01302 364 551

Fax: 01302 322 401

Email: heras.sales@herasuk.co.uk

Connect with us



Accreditations

As part of CRH Fencing & Security Group (UK) Ltd Heras UK Fencing Systems are accredited by:



Heras U.K. Fencing Systems is a division of CRH Fencing & Security Group (UK) Ltd



Let us inspire you
www.heras.co.uk

Issue 4: 09/15