

HADDONSTONE

Flooring, Paving & Steps





VISIT US

At East Haddon, in the rolling countryside of Northamptonshire in England, Haddonstone has beautiful show gardens and an interior showroom where visitors can see many of the designs illustrated in this catalogue in their proper settings, see opposite. The garden and showroom are open every week from Monday to Friday ~ public holidays and Christmas period excepted ~ between the hours of 9.00 am and 5.00 pm. The gardens are also open on occasional weekends as part of the National Garden Scheme (Yellow Book) to raise money for charity. Brown tourism signs guide visitors to the gardens from the A428.

Haddonstone pieces may also be viewed at stockists across the UK as well as the RHS gardens at Wisley and Harlow Carr. In addition, Haddonstone, TecLite, TecStone and Technistone designs can be seen at Pennine Stone Ltd, Askern Road, Carcroft, Doncaster DN6 8DE. Haddonstone's catalogue can be obtained from the Building Centre, Store Street, London WC1 or viewed online at:

www.haddonstone.com/view-catalogue

In the USA, Haddonstone offices have a permanent showroom display, whilst Haddonstone designs may also be viewed at stores and distributors across North America.

WHY HADDONSTONE?

Haddonstone is a unique form of cast limestone with a surface texture similar to Portland stone. The material matures and weathers like natural stone yet, piece for piece, normally costs significantly less than quarried stone.

The ability to mould the Haddonstone material into almost any shape ~ faithfully reproducing new designs or producing replicas that are virtually indistinguishable from an antique original ~ has won the company numerous contracts ranging from leading international hotels and retail developments to listed National Trust properties and prestige residential projects.

The material used in every design, from the smallest planter to the largest Corinthian column, exceeds the compressive cube strength requirements of the United Kingdom Cast Stone Association and complies with all relevant UK and European standards, whilst TecStone also meets the requirements of all US standards.

Each design is hand made by Haddonstone in the UK or USA using moulds created within the company's extensive mould shops and studios. Using these same facilities Haddonstone can even manufacture non-standard architectural stone pieces to practically any shape, size or colour.

As Haddonstone maintains original models and/or moulds for every single design in the standard collection, and utilises the very latest vapour curing technology, customers can be reassured that the high quality of each stone produced is incredibly consistent whilst retaining the individuality of a hand-made product. The company even offers a five year warranty on cast stone garden ornaments.

Haddonstone can also be an enjoyable investment. At a Sotheby's auction, four Haddonstone Plaited Baskets sold for more than twenty times their current retail value.

Haddonstone ~ one of the few things in life that can grow more beautiful and valuable with the passing of the years.

ARCHITECTURAL STONework FLOORING & PAVING

Haddonstone offers a range of flooring and paving designs for interior and exterior use. Weight: 89kg per m² (18 lb per ft²)

For interior use, the conservatory and orangery flooring ranges are etched and a seal applied at our manufactory before dispatch. Both then require sealing by the client after installation.

Like quarried stone, Haddonstone can exhibit slight shade variations from piece to piece, reflecting the colour of the natural materials used in the production process.



Conservatory Flooring

Suitable for indoor use. Standard sizes can be combined to create many different patterns.

HN722A: 300 x 300 x 25mm (11¹³/₁₆" x 11¹³/₁₆" x 1")

HN725A: 450 x 450 x 25mm (17³/₄" x 17³/₄" x 1")

HN726A: 450 x 225 x 25mm (17³/₄" x 8⁷/₈" x 1")

For exterior applications, see Smooth Paving on page 167.



Orangery Flooring

Suitable for indoor use. A traditional Victorian-style flooring system which can be seen to best effect if ordered in contrasting colours as shown above.

HN750A / HN755A: 394 x 394 x 38mm (15¹/₂" x 15¹/₂" x 1¹/₂")

HN750B: 102 x 102 x 38mm (4" x 4" x 1¹/₂")

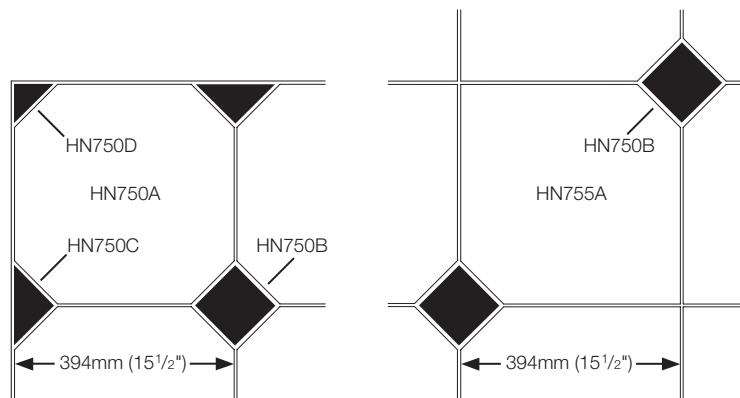

ARCHITECTURAL STONework PAVING

Textured Paving **HN800/HN801/HN805**

Haddonstone manufactures a range of paving with a subtle texture which is available in the following sizes:

HN800A: 600 x 600 x 38mm
(23⁵/₈" x 23⁵/₈" x 1¹/₂")

HN801A: 600 x 300 x 38mm
(23⁵/₈" x 11¹³/₁₆" x 1¹/₂")

HN802A: 300 x 300 x 38mm
(11¹³/₁₆" x 11¹³/₁₆" x 1¹/₂")

HN805A: 450 x 450 x 38mm
(17³/₄" x 17³/₄" x 1¹/₂")

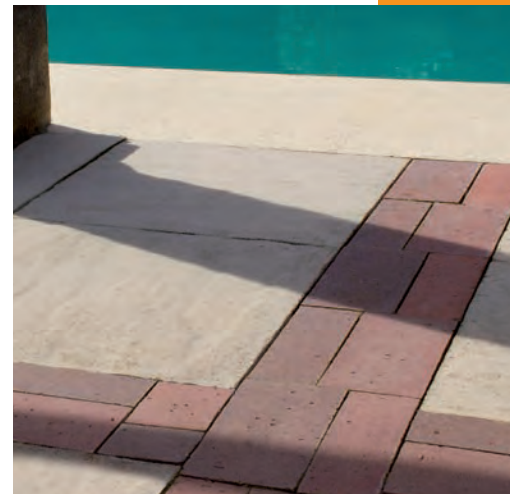

Riven Paving **HN855**

Customers can achieve a random effect by alternating the grain direction. In addition to the standard colours, Riven Paving is also available in York colour as shown above. Available in one size only:

Size: 450 x 450 x 38mm (17³/₄" x 17³/₄" x 1¹/₂")

Smooth Paving

Suitable for exterior use. Standard sizes can be combined to create many different patterns, see photograph page 168.

For interior applications, see Conservatory Paving on page 166.

HN700A: 600 x 600 x 38mm (23⁵/₈" x 23⁵/₈" x 1¹/₂")

HN701A: 600 x 300 x 38mm (23⁵/₈" x 11¹³/₁₆" x 1¹/₂")

HN702A: 300 x 300 x 38mm (11¹³/₁₆" x 11¹³/₁₆" x 1¹/₂")

HN705A: 450 x 450 x 38mm (17³/₄" x 17³/₄" x 1¹/₂")

HN706A: 450 x 225 x 38mm (17³/₄" x 8⁷/₈" x 1¹/₂")

Haddon Pavers **HN870/HN871**

Haddonstone offers simple paver-style blocks that can be used to compliment the company's various paving ranges.

These are only available in two special colours: Brindle Red -10 (top) and Brindle Blue -11 (bottom), as illustrated, in the following sizes:

HN870A: 210 x 100 x 38mm (8¹/₄" x 3¹⁵/₁₆" x 1¹/₂")

HN871A: 210 x 65 x 38mm (8¹/₄" x 2⁹/₁₆" x 1¹/₂")

General Note: Paving

A well-laid foundation is essential for effective and lasting results. A fall of at least 1 in 60 is recommended. For a clean architectural appearance, the joints can be mortar-pointed. For a softer, natural appearance, paving should be laid edge to edge, unpointed, with sand brushed into the joints. This method also facilitates drainage. Cement and mortar stains are difficult to remove from paving so extreme care must be taken to keep surfaces clean. Four clear days should be allowed to elapse after construction before foot traffic is allowed over all laid areas. For vehicular traffic, special laying instructions are available on application.

ARCHITECTURAL STONework PAVING & STEPS

Haddonstone's standard paving and steps can be used to great effect in numerous garden and landscape applications.

Custom sizes can be created to meet customer requirements or the slabs can be cut on site by professional contractors.

Smooth Paving in custom sizes at the Army Air Corps Memorial, Hampshire.



HN1 Treads with HN3 Risers.



Terracotta coloured HN1 Treads with HN3 Risers.



Steps

IMPORTANT: Haddonstone steps must be continuously bedded.

Treads are available, as standard, in a plain bull nose or a moulded design as shown, in lengths of 1000mm (39³/₈"") and in standard widths of 300mm (11³/₈""), 375mm (14³/₄"") and 450mm (17¹/₁₆""). These treads can be supplied with mouldings returned to left or right-hand ends. Square-edged risers are also available to suit. We have a range of curved treads and risers to meet individual requirements.

Treads and risers are produced in TecStone as standard.

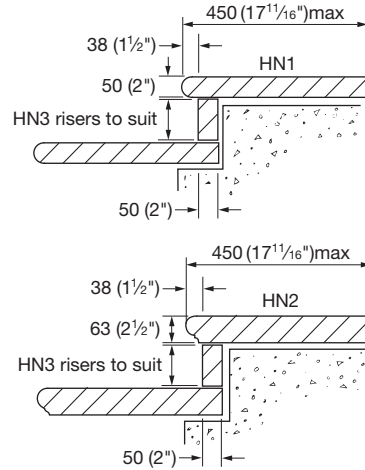

HN1 Treads with HN3 Risers.



HN1 Treads with HN3 Risers.

Spiral Steps

Haddonstone has introduced a spiral staircase that is both simple and elegant.

With the riser and locating ring being an integral part of each step, a complete staircase can provide a functional design solution for both traditional and contemporary projects. Principally designed for interior use, the steps are available in widths up to 1200mm (47¹/₄"").

We strongly recommend that professional advice is taken to ensure that any proposal is designed to be structurally sound. For further information please contact your nearest Haddonstone office.

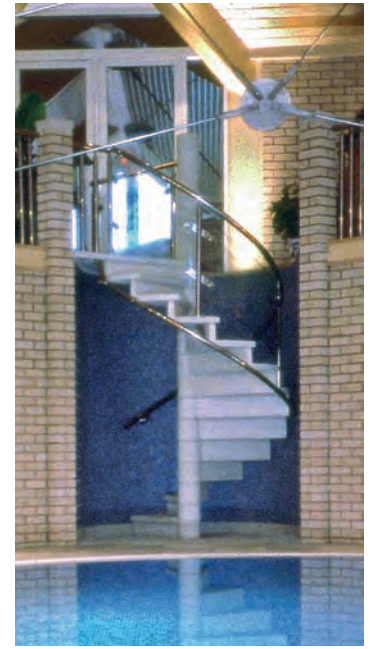



Dedicated to
the memory of
Adrian Coles

Editor: Simon Scott
Artwork: Miranda Eldridge
Principal photographers:
Hugh Palmer & Robin Teall

Copyright © 2012 Haddonstone Ltd. All rights reserved. Except as allowed by law, no part of this publication may be reproduced in any form without the written permission of Haddonstone Ltd.

Please note also that much of Haddonstone's garden ornamentation, architectural stonework and related Tech Sheets and computer programs are subject to registered design, copyright and similar proprietary protections under the laws of various jurisdictions. No pieces contained in this catalogue, or supplied by Haddonstone, should be copied or modified without first consulting the company in writing for permission. Violators of such proprietary rights are subject to severe civil and criminal penalties under law.

The terms "HADDONSTONE", "TECSTONE", "HADDON-TECSTONE", "TECCAST", "TECLITE", "STONEAGE", "TECHNISTONE", "HADDONCRAFT", "ARCADIAN" and "PENNINE STONE" and the stylised forms of these terms are, and in certain instances are registered as, trademarks and service marks of Haddonstone Ltd.



HADDONSTONE

Haddonstone Ltd,
The Forge House, East Haddon, Northampton NN6 8DB, England.
Telephone: 01604 770711 Fax: 01604 770027 info@haddonstone.co.uk

Haddonstone (USA) Ltd,
201 Heller Place, Bellmawr, NJ 08031, USA.
Telephone: 856 931 7011 Fax: 856 931 0040 info@haddonstone.com

Haddonstone (USA) Ltd,
32207 United Avenue, Pueblo, CO 81001, USA.
Telephone: 719 948 4554 Fax: 719 948 4285 stone@haddonstone.com

www.haddonstone.com

