



HADDONSTONE

Gate Piers, Pier Caps, Copings & Cappings





VISIT US

At East Haddon, in the rolling countryside of Northamptonshire in England, Haddonstone has beautiful show gardens and an interior showroom where visitors can see many of the designs illustrated in this catalogue in their proper settings, see opposite. The garden and showroom are open every week from Monday to Friday ~ public holidays and Christmas period excepted ~ between the hours of 9.00 am and 5.00 pm. The gardens are also open on occasional weekends as part of the National Garden Scheme (Yellow Book) to raise money for charity. Brown tourism signs guide visitors to the gardens from the A428.

Haddonstone pieces may also be viewed at stockists across the UK as well as the RHS gardens at Wisley and Harlow Carr. In addition, Haddonstone, TecLite, TecStone and Technistone designs can be seen at Pennine Stone Ltd, Askern Road, Carcroft, Doncaster DN6 8DE. Haddonstone's catalogue can be obtained from the Building Centre, Store Street, London WC1 or viewed online at:

www.haddonstone.com/view-catalogue

In the USA, Haddonstone offices have a permanent showroom display, whilst Haddonstone designs may also be viewed at stores and distributors across North America.

WHY HADDONSTONE?

Haddonstone is a unique form of cast limestone with a surface texture similar to Portland stone. The material matures and weathers like natural stone yet, piece for piece, normally costs significantly less than quarried stone.

The ability to mould the Haddonstone material into almost any shape ~ faithfully reproducing new designs or producing replicas that are virtually indistinguishable from an antique original ~ has won the company numerous contracts ranging from leading international hotels and retail developments to listed National Trust properties and prestige residential projects.

The material used in every design, from the smallest planter to the largest Corinthian column, exceeds the compressive cube strength requirements of the United Kingdom Cast Stone Association and complies with all relevant UK and European standards, whilst TecStone also meets the requirements of all US standards.

Each design is hand made by Haddonstone in the UK or USA using moulds created within the company's extensive mould shops and studios. Using these same facilities Haddonstone can even manufacture non-standard architectural stone pieces to practically any shape, size or colour.

As Haddonstone maintains original models and/or moulds for every single design in the standard collection, and utilises the very latest vapour curing technology, customers can be reassured that the high quality of each stone produced is incredibly consistent whilst retaining the individuality of a hand-made product. The company even offers a five year warranty on cast stone garden ornaments.

Haddonstone can also be an enjoyable investment. At a Sotheby's auction, four Haddonstone Plaited Baskets sold for more than twenty times their current retail value.

Haddonstone ~ one of the few things in life that can grow more beautiful and valuable with the passing of the years.

ARCHITECTURAL STONEWORK GATE PIERS

Gate Pier S120

This gate pier is a standard item in the Haddonstone collection. Heights can be varied according to the number of centre shaft units used. When ordering please note that each course is supplied in two halves. Both halves need to be ordered. Custom-made products are available on request.

If the gate piers are to be infilled with concrete the shaft sections should be lined with 25mm (1") polystyrene (Styrofoam) or similar to act as an isolating medium. It is most important to refer to the relevant Tech Sheet to ensure correct installation.

Haddoncraft Forge is able to supply gates and railings to individual specifications for use in conjunction with these Gate Piers, see page 183.

TS Tech Sheet No. M40

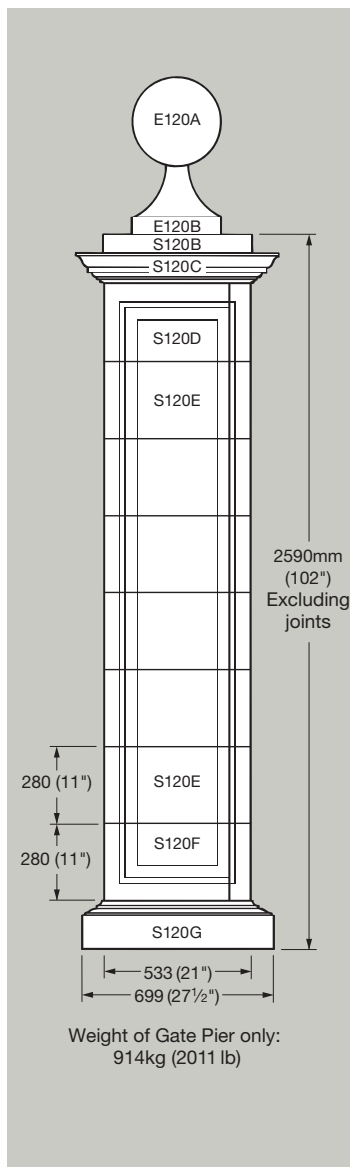

Custom gate pier.



Custom gate pier.

ARCHITECTURAL STONEMASONRY PIER CAPS

Haddonstone has a large selection of Pier Cap designs in a range of sizes. If your requirements are not featured we can produce custom designs to your specifications.

For Finials and Balls & Bases to complement our range of Pier Caps refer to pages 71-74.

TS Tech Sheet No. PC10 & PC11

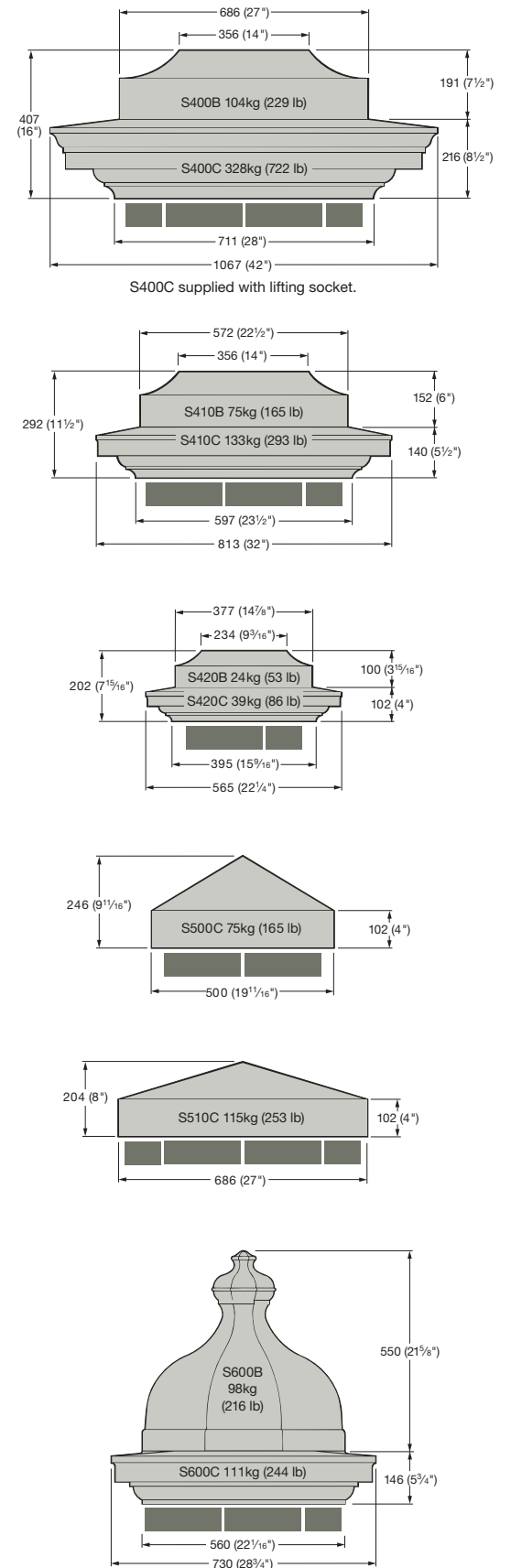
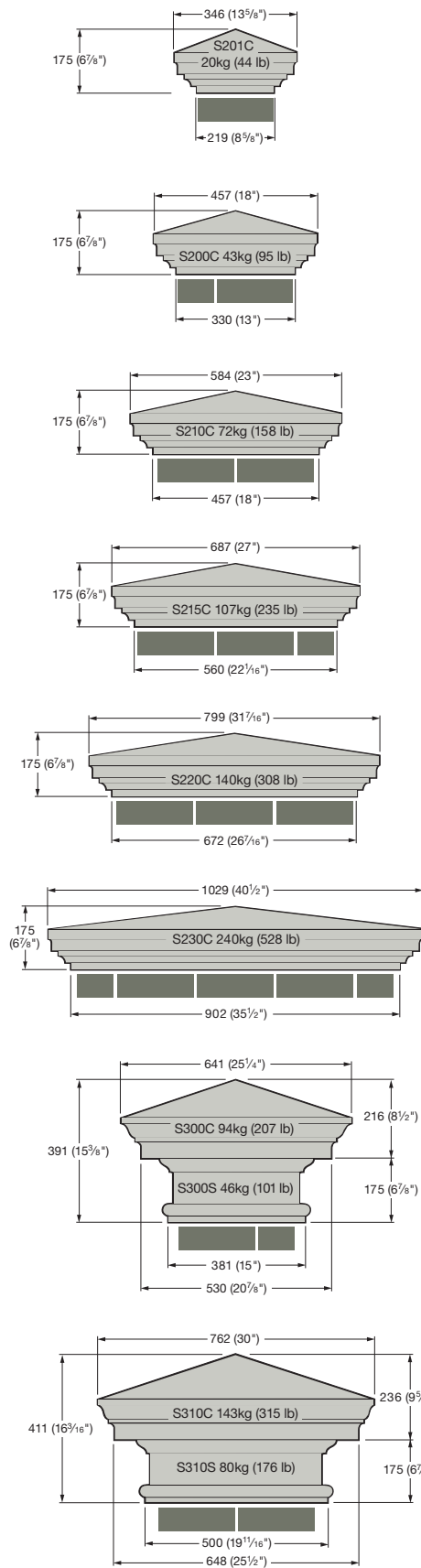
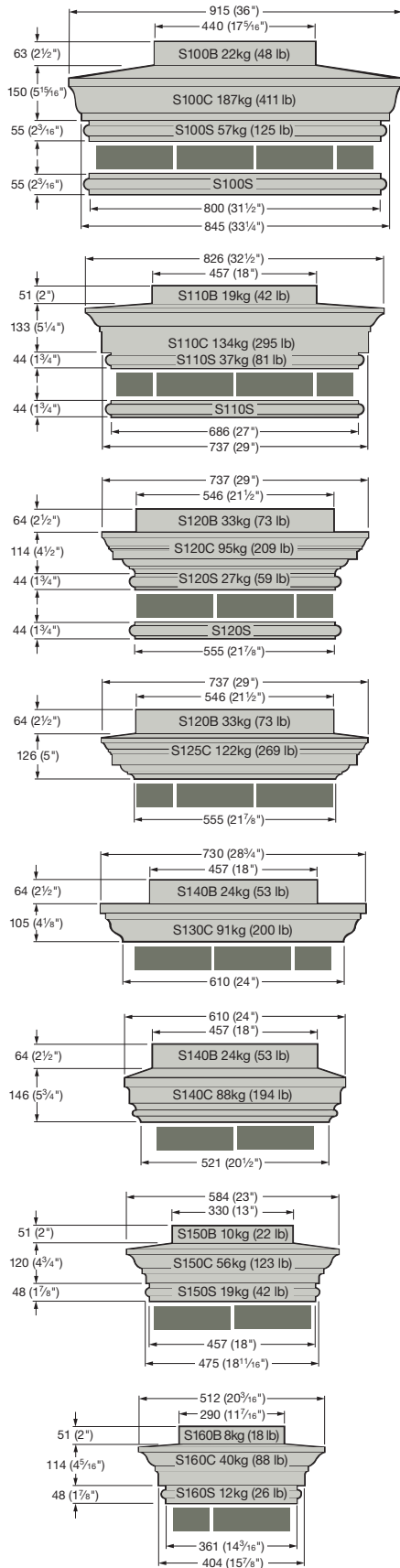

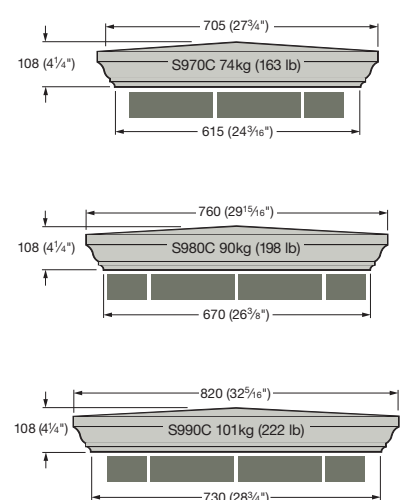
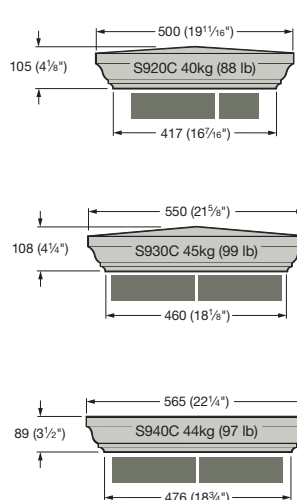
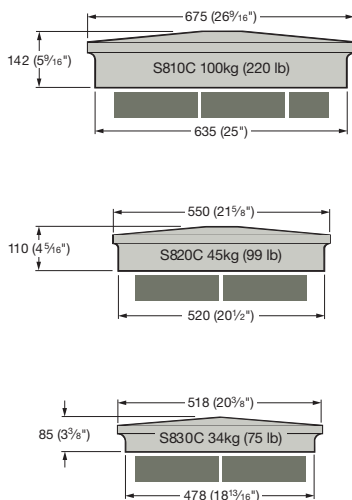
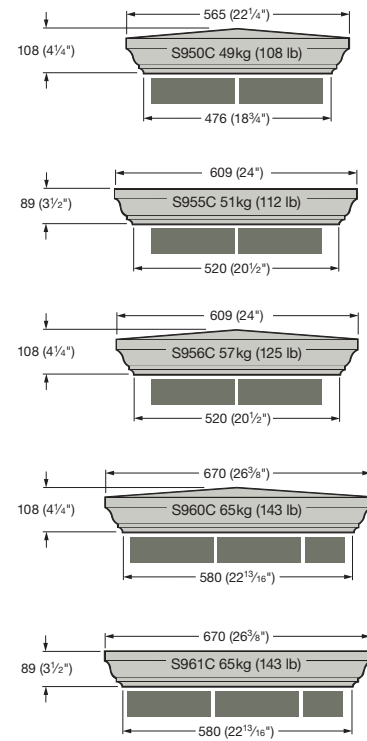
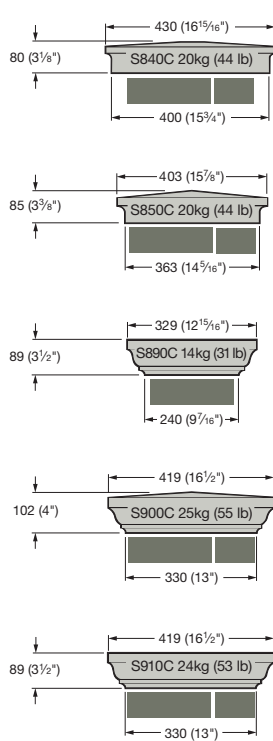
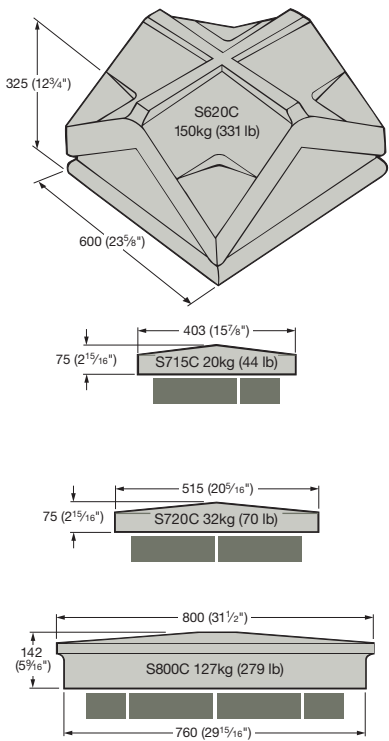

S955C - 32" underside version of S990C. (USA only)
S997C - 36" underside version of S990C. (USA only)

ARCHITECTURAL STONEMWORK COPINGS & CAPPINGS

The Haddonstone collection includes copings and cappings in many designs. Most requirements for straight flat runs of wall, curved wall sections, ramped walls, serpentine walls and stepped walls can be met from our standard range.

We would be pleased to discuss your special requirements.

For standard lengths, please refer to the price list. Custom-made Copings and Cappings are available on request.

All copings and cappings are supplied throated, although not necessarily to BS 5642: 1983 in certain applications. We strongly recommend that you refer to Eurocode 6 and PD 6697: 2010.

TS Tech Sheet No. WC10, WC20 & WC30

13" Ball & Collared Base (see p74), Block S140B, Cap S130 & Coping T150.

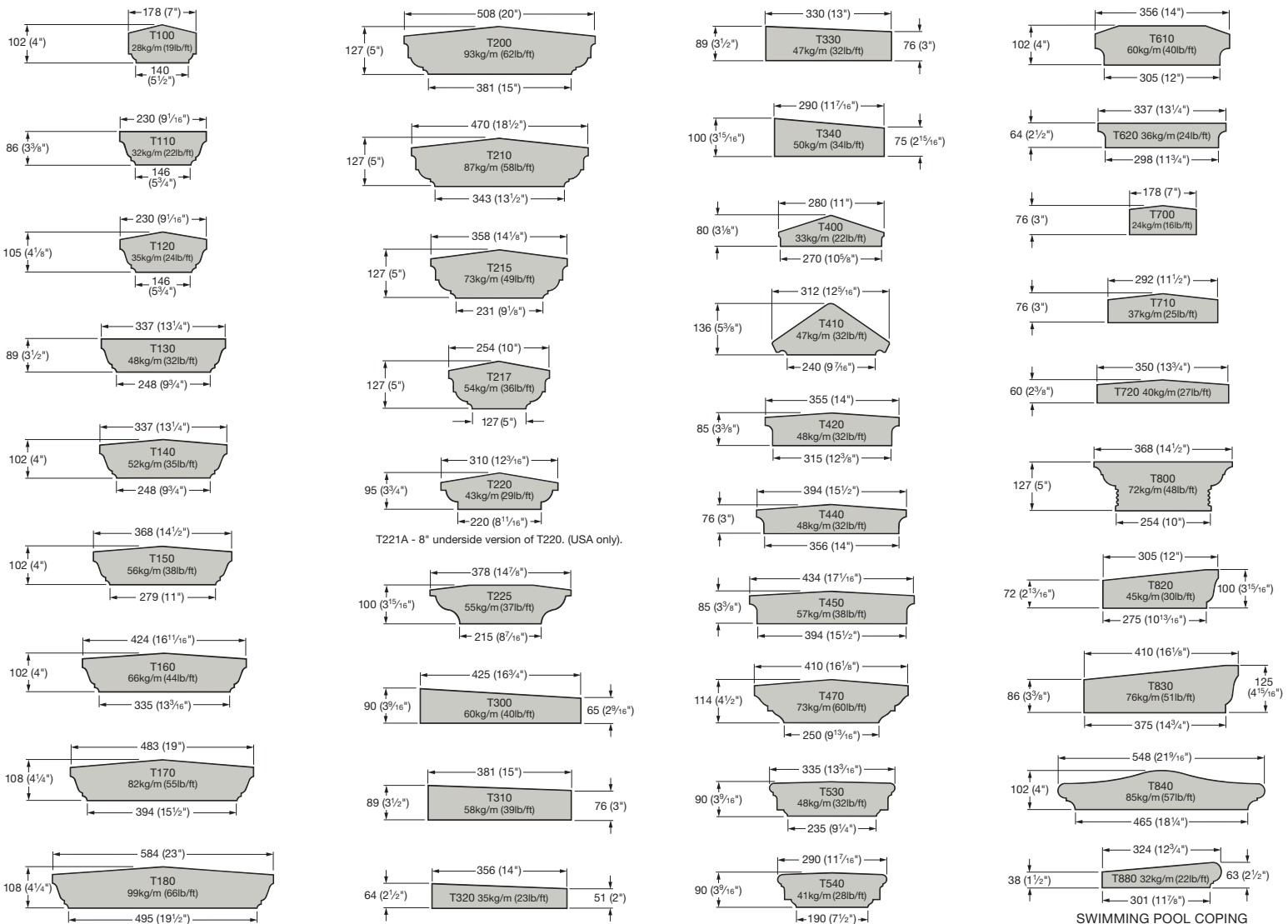

To assist our private and professional clients with the ordering of Haddonstone copings and cappings, we have introduced this new page to the catalogue containing all the relevant terminology required.

For further details relating to coping and capping terminology, please either contact your nearest Haddonstone office or refer to:

TS Tech Sheet No. WC10, WC20 & WC30

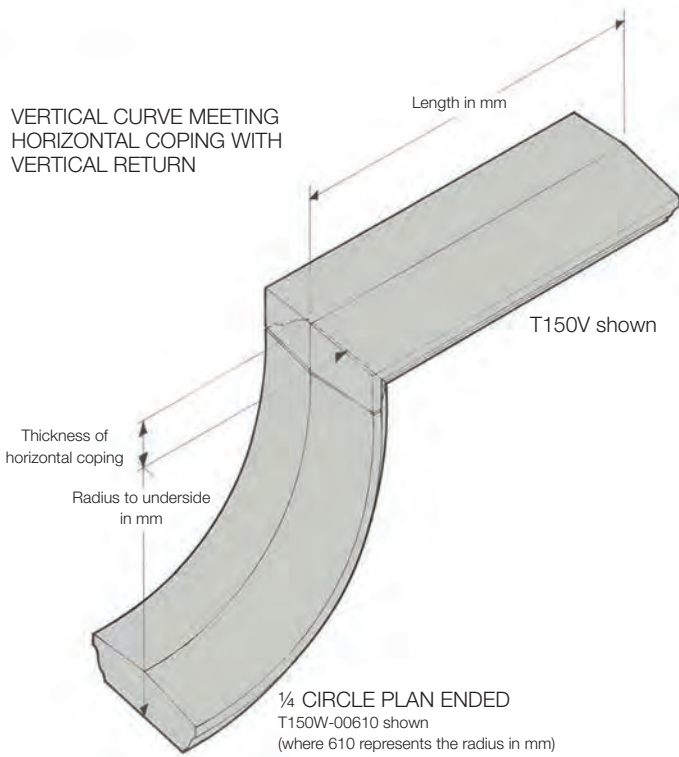

Pier Caps S600B/C and S960C with Coping T150.

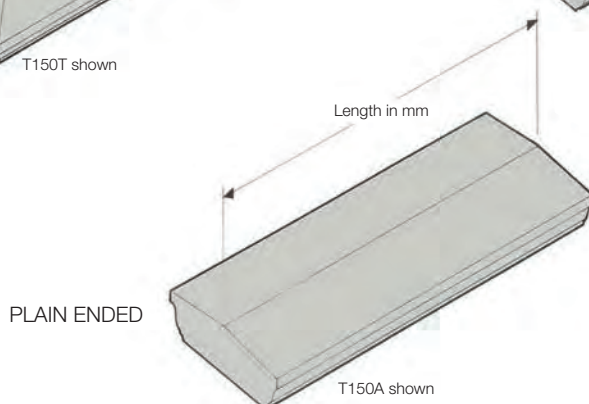
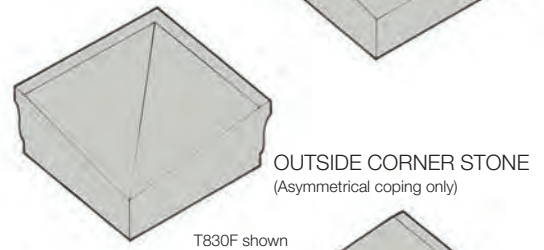
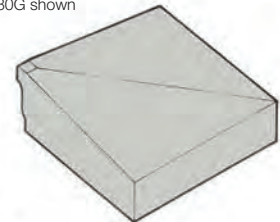
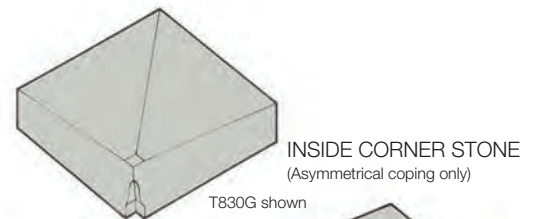
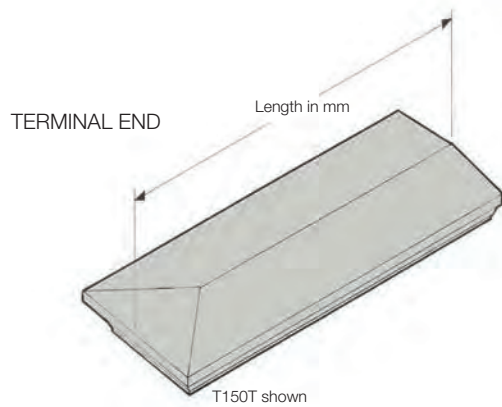
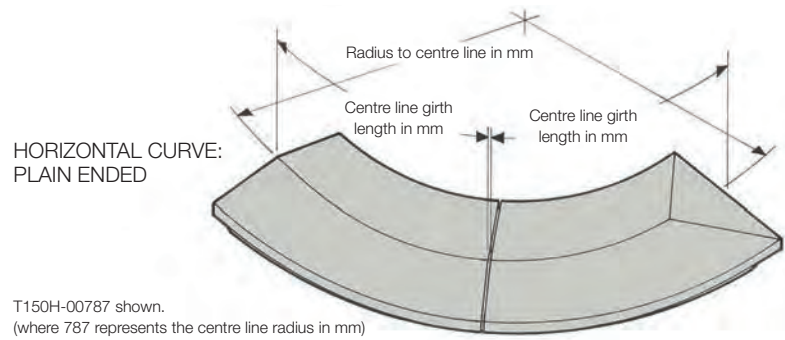



Dedicated to
the memory of
Adrian Coles

Editor: Simon Scott
Artwork: Miranda Eldridge
Principal photographers:
Hugh Palmer & Robin Teall

Copyright © 2012 Haddonstone Ltd. All rights reserved. Except as allowed by law, no part of this publication may be reproduced in any form without the written permission of Haddonstone Ltd.

Please note also that much of Haddonstone's garden ornamentation, architectural stonework and related Tech Sheets and computer programs are subject to registered design, copyright and similar proprietary protections under the laws of various jurisdictions. No pieces contained in this catalogue, or supplied by Haddonstone, should be copied or modified without first consulting the company in writing for permission. Violators of such proprietary rights are subject to severe civil and criminal penalties under law.

The terms "HADDONSTONE", "TECSTONE", "HADDON-TECSTONE", "TECCAST", "TECLITE", "STONEAGE", "TECHNISTONE", "HADDONCRAFT", "ARCADIAN" and "PENNINE STONE" and the stylised forms of these terms are, and in certain instances are registered as, trademarks and service marks of Haddonstone Ltd.



HADDONSTONE

Haddonstone Ltd,
The Forge House, East Haddon, Northampton NN6 8DB, England.
Telephone: 01604 770711 Fax: 01604 770027 info@haddonstone.co.uk

Haddonstone (USA) Ltd,
201 Heller Place, Bellmawr, NJ 08031, USA.
Telephone: 856 931 7011 Fax: 856 931 0040 info@haddonstone.com

Haddonstone (USA) Ltd,
32207 United Avenue, Pueblo, CO 81001, USA.
Telephone: 719 948 4554 Fax: 719 948 4285 stone@haddonstone.com

www.haddonstone.com

