

A-Series Window

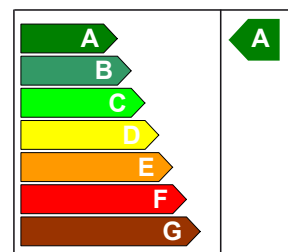

Window Energy Rating



This is a high performance stormproof casement window available as side hung or top hung with the option of glazing bars to create classic designs.

We design and manufacture a range of high performance 'A-Series' windows. It is hung on reflex hinges, externally beaded and has a decorative internal mould on both sash and frame to lend it a more attractive appearance.



SPECIFICATIONS

SIZES

Our A-Series window is available in the following standard sizes:-

Widths (mm) 624, 1,200, 1,776, 2,352
 Heights (mm) 900, 1,050, 1,200, 1,350, 1,500

We also manufacture to these minimum sizes:

Width (mm) 400,
 Height (mm) 400

PERFORMANCE

Tested independently and approved to BS 6375 Part 1, E 2500 exposure category and the following pressure class ratings:

- Air Permeability: 600Pa
- Water Tightness: 1,950Pa
- Wind Resistance: 2,500Pa

Our windows are factory-fitted with dual weather-strips which give a water-tight seal and a high level of energy efficiency.

An 'A' energy rating is available for its high thermal performance, and is available with triple glazing for even more insulation.

A+ rated on the BRE Green Guide

GLAZING

28mm (4/20/4) 'Low E' double glazed units, manufactured to BSEN1279, are factory fitted as standard.

CONSTRUCTION

As standard, the windows are made from quality redwood. A hardwood option is also available.

The range is constructed from generously proportioned timber sections.

GLAZING

Using glazing rebates of 46 x 18mm, our A-Series window is factory fitted as standard with 28mm (4/20/4) 'Low E' double glazed sealed units. The glazing system has timber beads all round as standard.

The beading is secured using Allan Brothers' fixing system to enhance product integrity and appearance.

Specialist glazing, e.g., argon filled, patterned glass or laminated, can be fitted, if required, to give additional insulation and/or security. A range of glazing bars and astragals can also be fitted on request.

SECURITY

Designed to score an A+ rating to meet and exceed the requirements of BS 7950 - Enhanced security for windows in private dwellings, this range offers a stronger and more effective deterrent to would-be burglars and vandals than ever before. This, also combined with the assurance of quality, styling and attention to detail makes the A-Series the window of choice for building companies concerned with security.

- Security locking by shoot-bolt espagnolette system with 6 locking points.
- High performance security glazing features double sided tape with a silicone infill around the unit and secured with our glazing system.
- A+ enhanced security exceed to BS 7950 standards.

IRONMONGERY

This window is fitted with a stainless steel adjustable friction hinge which allows opening to 60° for easy cleaning. It is also available with a restrictor to limit initial opening of the window to under 100mm in accordance with BS 8213 Part 1:2004. In addition, an egress hinge which allows opening to 90° can be fitted to meet regulations for emergency access and egress.

FACTORY FINISH

Allan Brothers' products are treated with preservative after all machining. This is applied by means of a double vacuum process in accordance with BS8417 and NHBC recommendations.

Our water-based coatings are carefully formulated to seal the end-grain against moisture ingress, inhibit tannin stain and give the timber a quality look and feel.

VENTILATORS

Ventilators are fitted as standard within the frame head to eliminate the need for a vulnerable and unsightly external hood.

All ventilators comply with current building regulations: Approved Document F England & Wales and Scottish Building Standards Section 3.

OTHER TECHNICAL INFORMATION

Allan Brothers provide a full technical back-up service covering all aspects of product and glazing performance.

Technical information, including detailed drawings, guidelines for installation and storage and operating and maintenance instructions, is available on request.

Window Energy Rating

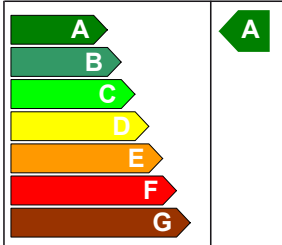

Allan Brothers Limited

Allan House, Ord Road,
 Berwick-Upon-Tweed, TD15 2XU
 Telephone: 01289 334 600
 Fax: 01289 334 601
www.allanbrothers.co.uk

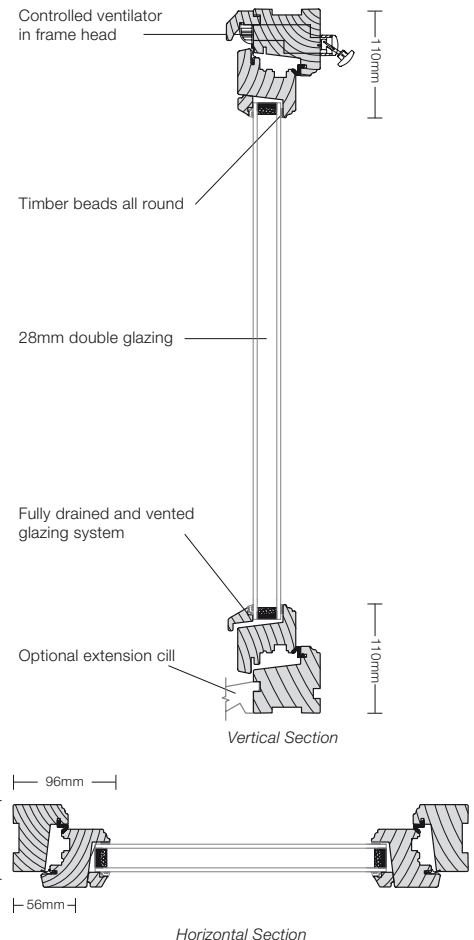

Available in 68mm and 92mm profiles.