

# Storage Cylinder Combination

Andrews continuous flow water heaters can be combined with our range of ST storage cylinders to provide large volumes of hot water for peak flow use. This is especially useful in cases where the hot water flow rate requirement exceeds the flow capacity of the heaters for a limited period. Or where there is an intermittent large demand for hot water such as hospitals, hotels, apartments, sports changing rooms and health clubs.

## Storage Cylinder Details

	ST66	ST100	ST166
Capacity	304 ltrs	452 ltrs	754 ltrs
Connection	Rc2	Rc2	Rc2
Thermostat Connection	Rc3/4	Rc3/4	Rc3/4
Height	1537mm	1638mm	2019mm
Diameter	667mm	762mm	889mm
Weight Empty	95.2kg	141kg	245kg
Weight Full	400kg	593kg	999kg
Max pressure	10.3 bar	10.3bar	10.3bar

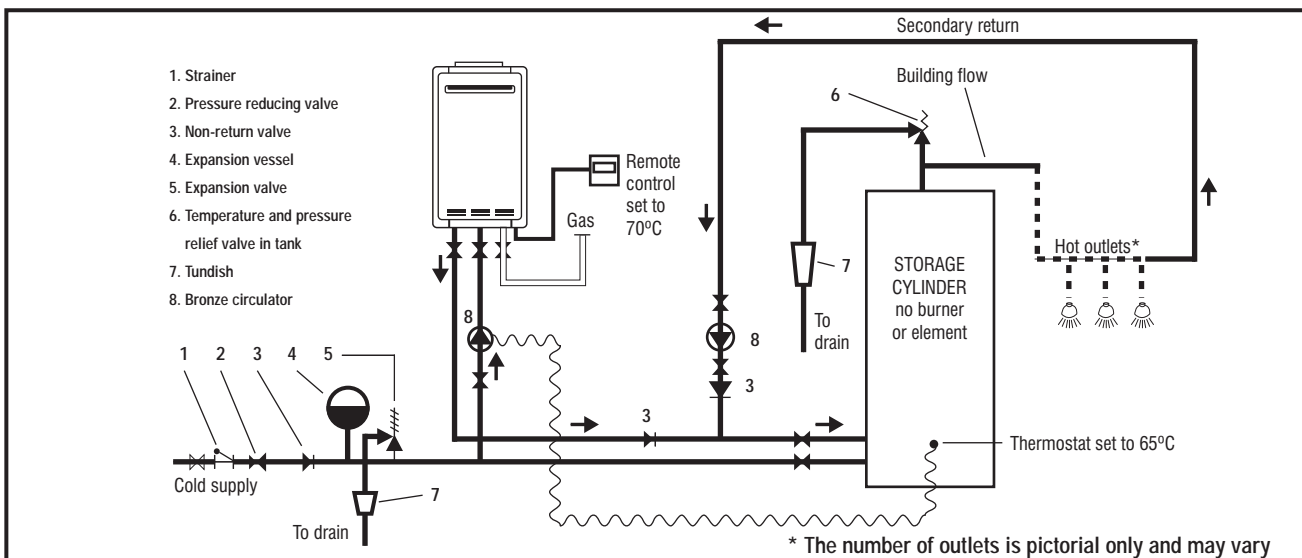

Schematic diagram shows single WH/WHX unit with additional storage cylinder, plus pipework and valve arrangement. Units should be pre-set to a minimum set point of 70°C to maintain 65°C flow from the cylinder. Please refer to the Andrews Design and Installation guide for further information.

## Circulating pumps

When installing single or multiple units on a secondary pumped re-circulation system a minimum flow rate must be maintained to achieve optimum performance from the appliance, please refer to the pump selection table. When installing multiple units in conjunction with a storage cylinder the full heat output of all heaters is required to provide maximum recovery volume and thus reduced recovery times. In this case the pump must be sized to give a certain minimum flow rate through each heater. Selection data for the size of pump required are shown in the pump selection table.

## Pump Selection Table

Pump selection using single or multiple units on a secondary return system (pump required for first unit only)			
Number of units	Flow rate required	Approximate head	Speed setting
1	8 ltrs/min (0.13 ltrs/sec)	50kPa	2
Pump selection using multiple units with storage cylinder (flow through all units)			
2	16 ltrs/min (0.27 ltrs/sec)	50kPa	2
3	24 ltrs/min (0.40 ltrs/sec)	60kPa	2
4	32 ltrs/min (0.53 ltrs/sec)	60kPa	3
5	40 ltrs/min (0.67 ltrs/sec)	60kPa	3

A suitable bronze pump kit can be supplied by Andrews, please contact our Sales Department for further details.



0087



**ANDREWS WATER HEATERS**  
**Wednesbury One, Black Country New Road,**  
**Wednesbury, West Midlands WS10 7NZ**  
**Tel: 0121 506 7400 Fax: 0121 506 7401**

**Email: [andrews@andrews-waterheaters.co.uk](mailto:andrews@andrews-waterheaters.co.uk)**  
**Web: [www.andrewswaterheaters.co.uk](http://www.andrewswaterheaters.co.uk)**



C/SIB

(53.5) Xh

November 2005

# FASTflo

*CONTINUOUS FLOW WALL HUNG BALANCED FLUE WATER HEATERS*



# FASTTflo

## CONTINUOUS FLOW WALL HUNG BALANCED FLUE WATER HEATERS & ACCESSORIES

The new FASTTflo range from Andrews Water Heaters are ideal for commercial or large domestic applications where an endless supply of hot water is required. Unlike old instantaneous type water heaters, the revolutionary design measures the incoming water flow and temperature via the primary circuit board. It then modulates the burner up or down to meet the desired hot water demand with plus or minus one degree accuracy. This technology ensures a continuous flow of hot water, that is also very safe to operate\*. All models are suitable for wall mounting thus reducing installation space and each unit is supplied with a BS Gas Cock, Installation Manual and Owners Guide.

### Further benefits include:

- Hot water on demand, with efficiency up to 89%
- Modulating burner and no stand-by heat losses
- Automatic ignition means no costs whilst unit is not in use
- Compact and light for easy location and installation
- Accurate temperature settings from 37°C to 80°C
- Internal room sealed and external models
- Factory fitted anti-frost protection on all models
- Safe and constant flow of endless hot water
- Reduced risk of harmful legionella bacteria forming
- Flue systems to suit most applications

\* Thermostatic mixing valves must be fitted at point of use in some applications. Health Guidance Note TMV3 scheme refers.



INTERNAL  
**WH42**  
**WH56**



EXTERNAL  
**WHX42**  
**WHX56**

### Specifications

Model (Natural Gas)	WH42	WH56	WHX42	WHX56
Model** (Propane)	LWH42	LWH56	LWHX42	LWHX56
Width	450mm	450 mm	450 mm	450 mm
Height	615 mm	615 mm	615 mm	615 mm
Depth	240 mm	240 mm	240 mm	240 mm
Weight	29kg	29kg	30kg	30kg
Flue Type	Single pipe 100mm	Single pipe 100mm	External no Flue required	External no Flue required
Heat input net	49.0kw	62.3kw	49.0kw	62.3kw
Heat output net	42.0kw	55.8kw	42.0kw	55.8kw
Gas rate natural	5.1m <sup>3</sup> /hr	6.5m <sup>3</sup> /hr	5.1m <sup>3</sup> /hr	6.5m <sup>3</sup> /hr
Gas rate propane	1.9m <sup>3</sup> /hr	2.5m <sup>3</sup> /hr	1.9m <sup>3</sup> /hr	2.5m <sup>3</sup> /hr
Nox emissions	52ppm	52ppm	52ppm	52ppm
Nox emissions	92mg/kWh	92mg/kWh	92mg/kWh	92mg/kWh
Nox emissions (propane)	72ppm	72ppm	72ppm	72ppm
Nox emissions (propane)	128mg/kWh	128mg/kWh	128mg/kWh	128mg/kWh
Noise Level dB(A)	49	49	49	49
Water connection	¾" BSP	¾" BSP	¾" BSP	¾" BSP
Gas connection (gas cooker supplied)	¾" BSP	¾" BSP	¾" BSP	¾" BSP
Max water pressure	10.0 bar	10.0 bar	10.0 bar	10.0 bar
Min water pressure***	1.0 bar	1.0 bar	1.0 bar	1.0 bar
Electric supply	230V	230V	230V	230V
Frequency	50Hz	50Hz	50Hz	50Hz
Fuse	10A	10A	10A	10A
Max flow rate	24 ltrs/min	32 ltrs/min	24 ltrs/min	32 ltrs/min
Min flow rate	3.5 ltrs/min	3.5 ltrs/min	3.5 ltrs/min	3.5 ltrs/min

\*\* L prefix propane models must be specified when ordering.

\*\*\* Note: Although the heaters operate at low water pressure, maximum performance is not attained unless the incoming pressure is 2 bar or more. On pumped circulation systems a minimum flow of 8 litres/min through each heater is required for optimum performance.

### Water flow at different temperature rises

Model	25°C		35°C		45°C		55°C		65°C	
	l/sec	l/min	l/sec	l/min	l/sec	l/min	l/sec	l/min	l/sec	l/min
WH42/WHX42	0.4	24	0.29	17	0.22	13	0.18	10.8	0.15	9
WH56/WHX56	0.53	32	0.38	23	0.3	18	0.24	15	0.21	12
LWH42/LWHX42	0.4	24	0.29	17	0.22	13	0.18	10.8	0.15	9
LWH56/LWHX56	0.53	32	0.38	23	0.3	18	0.24	15	0.21	12



## Remote Controller

A Remote Controller, designed especially for the Andrews WH and WHX range of heaters, is required to operate the appliance. This allows external adjustment of the required flow temperature and in addition provides a wide range of operation and fault diagnosis information. The remote controller is easily connected to the appliance by the low voltage cable supplied.

## Unvented System Kits

If continuous flow water heaters are used on circulation systems an unvented system kit is required to allow for expansion of the hot water system. The kit includes the necessary safety devices required to confirm to the current building regulations.

Three sizes of kit can be supplied and each contains a combined strainer/pressure reducing valve set to 3.5 bar, check valve, expansion valve set to 6.0 bar, tundish, 5 litre expansion vessel, wall bracket and hose.

When the circulation system includes a storage cylinder/buffer vessel, a combined temperature/pressure relief valve must be sized to suit the total input of all the water heaters installed on the system (see table below). This must be located on the storage unit. In addition the size of the expansion vessel must also be increased to suit both the storage cylinder plus the contents of the system pipework (see vessel table).

Unvented System Kit	
Part No:	Size:
B235	¾ inch dia.
B234	1 inch dia.
B276	1½ inch dia.
Expansion Vessel	
Part No:	Size:
C782	25 litre, 3.5 bar
C789	40 litre, 3.5 bar
E047	60 litre, 3.5 bar
C890	80 litre, 3.5 bar

Temperature and Pressure Relief Valves			Tundishes	
Part No:	Total Output	Quantity & Size of Valves	Part No:	Size
C380	Up to 56kw	1 x 1 inch	C384	1 inch - 1¼ inch
E242	Up to 112kw	1 x 1½ inch	E326	1½ inch - 2 inch
E242 + C456	Up to 126kw	1 x 1½ inch + 1 x ¾ inch	E497	2 inch - 2½ inch
E291	Up to 168kw	1 x 2 inch	E497	2 inch - 2½ inch
E291 + C380	Up to 224kw	1 x 2 inch + 1 x 1 inch	E497+C384	2 inch - 2½ inch + 1 inch -1¼ inch

## Multiple Units

Andrews continuous flow water heaters can be combined in multiples of up to six units to provide a plentiful supply of hot water. With a temperature rise of 45°C up to 1.8 litres/second (108 litres/minute) can be supplied constantly. Please refer to the water flow table. When installing two units in parallel, a quick connect multi system can be installed which requires only one remote controller and a quick connect cord. For multiple installations of up to six units a system controller is available. This will ensure that when a small draw off occurs all the flow will pass through the lead unit (priority changes) rather than dividing the flow through all of them. As the flow rate increases additional units will fire thus maintaining the required system flow temperature. Other standard features of the system controller includes BEMS fault indicator, remote 'power on' indicator, circulation pump connection and remote switching. The system controller is not required when the installation incorporates a storage cylinder/buffer vessel or if a constant large volume of hot water is required. Please contact our Sales Department for more details.

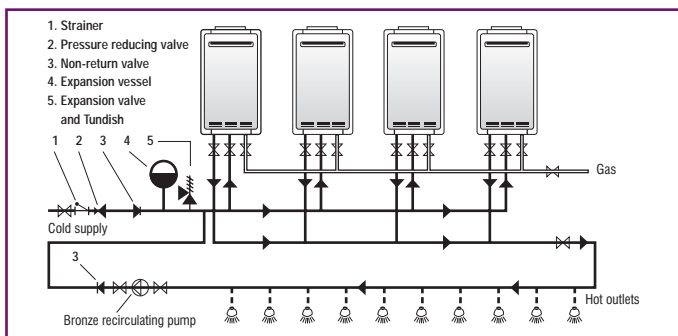

Manifolded units with primary flow and pumped secondary re-circulation pipework complete with suitably sized mains unvented systems kit.

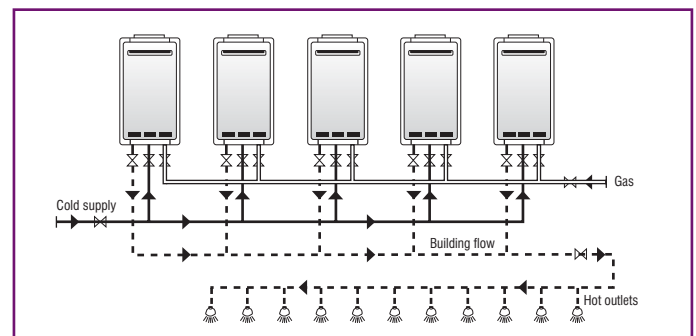

Five units connected in parallel without secondary re-circulation.

## Water Quality and Treatment

In hard water areas, scale formation can occur in hot water systems and water heaters. The higher the temperature and volume of water used, the more problematic the scale build-up can be. Water treatment is normally recommended when the hardness reaches 100-150ppm (7-10 degrees Clark) and above. This problem can be minimised by reducing the water flow temperature or by fitting suitable water pre-treatment equipment such as the Andrews KalGUARD hard water treatment device. Please contact our Sales Department for further details.