

# Commercial Ventilation

## Why unit ventilation ?

When it comes to air quality, there is nowhere more important than the workplace. At home the environment in which we live is largely within our control. At work the air we breathe and our thermal comfort is provided by others. Small wonder then that a World Health Organisation report suggests that up to 30% of new and refurbished buildings may be subject to excessive complaints relating to indoor air quality. The symptoms include headaches, eye, nose and throat irritation, dry coughs, dizziness and nausea, difficulty concentrating, fatigue and sensitivity to odours.

Since the 1970's as energy costs have risen, so buildings have become more airtight and in many cases the amount of recirculated fresh air has been reduced in order to improve energy efficiency. These reduced rates have been found to be, in many cases, inadequate to maintain the comfort and health of building occupants.

Frequently, problems result when the occupants activities are different from that which the building was originally intended.

Central systems can, in some cases, be energy wasteful as they ventilate all areas whether they are occupied or not. Studies have also shown that we react better to a varying air circulation than a carefully controlled consistent environment. The ability to control our own 'air space' to suit the activity or the number of people reduces the symptoms often referred to as sick building syndrome.

In retail and the hospitality sector, employers have an additional duty of care towards their staff with regard to passive smoking. Satisfactory air quality and thermal comfort is not just good for employee health, it's good for business too.

Localised heat, smells and moisture can be effectively removed with extract fans installed as close to the source as possible. In staff rooms, photocopying

rooms, toilets etc. usually a window or wall fan can be extremely effective.

In general office environments 4-6 air changes per hour is sufficient to provide circulation and remove volatile organic compounds from furnishings, cleaning agents and biological contaminants.

Unit ventilation can effectively extract tobacco smoke although specific provision of tempered air to the staff is recommended.

## Commercial Product selector

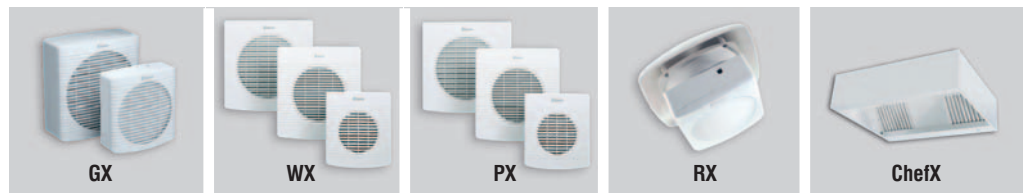

Page Number	68	70	72	74	76
Fan Type	Axial	Axial	Axial	Axial	Kitchen canopies
Positioning	Window	Wall	Ceiling / Panel	Roof	Over hob
Models	3	4	3	3	3
Max extract rate (m <sup>3</sup> /h)	1614	1715	1712	1100	2800
Max intake rate (m <sup>3</sup> /h)	1002	969	1037	915	
Max power (W)	85	85	85	87	940
Duct dia (mm)	n/a	n/a	200-315	n/a	See product

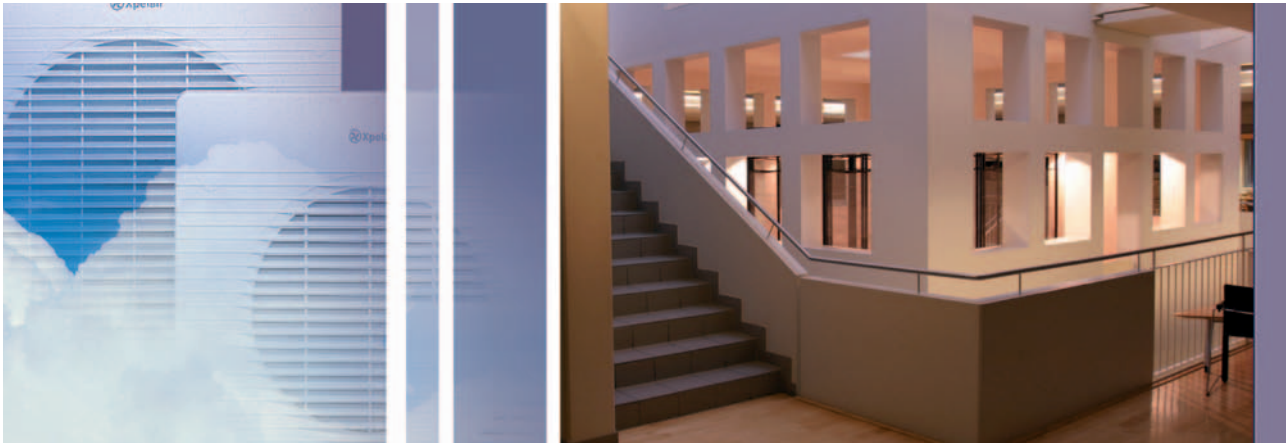

## Brochure Builder

Allows you to create your own e-brochure. It is an invaluable tool for specification work or for e-mailing product information. For further details visit [www.Xpelair.co.uk](http://www.Xpelair.co.uk) and follow the steps outlined below:

[www.applied-energy.com](http://www.applied-energy.com)



Click here to enter Brochure Builder.

[www.Xpelair.co.uk](http://www.Xpelair.co.uk)



You can also click on the advertising banner to enter Brochure Builder on the Xpelair homepage.

Brochure Builder

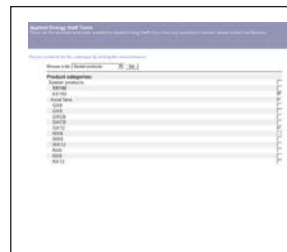

Once you have registered you are able to create your unique product brochure. Simply choose which brand/products you would like to include.

E-brochure



Once you have selected your products the electronic brochure is created so you can either print it yourself or e-mail to a customer.

# Xpelair GX6, GX9 & GX12

## Commercial window fans



### Key features

Type:	<b>Commercial duty ventilation unit</b>
Application:	<b>Pubs, restaurants, offices, kitchens, factories, schools and shops</b>
Control options:	<b>Extensive range of optional controllers available</b>
Legislation:	<b>Conforms to Building Regulations</b>



### The Range

Tried and tested, the Xpelair **GX6**, **GX9** and **GX12** window fans have remained a byword for commercial window fans for over forty years. The latest **GX** range is no exception – continuing that reputation for rugged reliability, whilst introducing a host of refinements to make the range safer, faster to install and easier to clean.

The contoured high gloss white housing is styled to blend in cleanly with modern décor. A shadow grey external grille is supplied for unobtrusive external appearance. For safety, a finger guard is integrated into the housing and the window grille design. On **GX9** & **GX12** range units, a tamper proof positive plug and socket assembly provides a means of isolation for service access without the safety risk of accidental disconnection. Installation in single and sealed double glazed windows (up to 25mm) is rapid

using Xpelair's unique metal ladder strip / screw system, ensuring a secure and watertight seal against the glass.

Both the **GX9** & **GX12** ranges are reversible and now feature totally enclosed external rotor motors providing constant volume outputs, even in gusty external conditions. Pre-balanced sickle bladed impellers eliminate 'fan judder' and ensure quiet trouble free operation. Sealed for life maintenance free bearings ensure suitability for running at any angle. Running costs are impressively low, and when not in use the silent electro-thermal shutter cassette closes silently against backdraughts. And cleaning has never been easier. The housing, shutter cassette and impeller are all removed in seconds.

### Select the right product for your application

		<b>GX6</b>	<b>GX9</b>	<b>GX12</b>
Reference number		90800AW	89994AW	90012AW
Remote switch (supplied separately)		■	■	■
Selectable intake, extract or controller operation			■	■
Speeds		1	2*	2*
Extract performance (FID, m <sup>3</sup> /h)	high	266	728	1614
	low		618	1214
Extract performance (FID, l/s)	high	74	202	448
	low		172	337
Intake performance (FID, m <sup>3</sup> /h)	high		456	1002
	low		412	819
Intake performance (FID, l/s)	high		127	278
	low		114	228
Sound pressure level (dB(A)@3m)	high	37	50	55
	low		48	50
Electrical power rating (W)		30	41	85
Weight (kg)		1.9	4	7.9
Hole Ø (mm)		184	257	324
Hole Ø with wall liner (mm)		203	266	330
Guarantee (years, UK)		3	3	3

\*low speed only applies if fan used with FR22/30 controller. If controller not used fan is only single (high) speed

## Models

### GX6

Ref. 90800AW

- 6" high performance extract axial ventilation unit
- Operated by remote On/Off switch (not supplied)
- Suitable for single and sealed double glazing windows and panels up to 25mm
- Sealed for life maintenance free bearings, suitable for running at any angle. Integrated safety thermal overload protection
- Built-in silent action electro-thermal shutter cassette
- Passive tricklevent facility for background ventilation with fan Off
- Easy clean high gloss ABS housing with integral finger safety guard
- Shadow grey external grille for unobtrusive external appearance
- Unique metal ladderstrip / screw connection to external grille for security and weather tight seal

### GX9

Ref. 89994AW

### GX12

Ref. 90012AW

- High performance intake/extract axial ventilation unit
- Choice of optional controllers
- Suitable for single and sealed double glazing windows and panels up to 25mm
- Balanced external rotor motor and impeller for quiet efficiency
- Sealed for life maintenance free bearings, suitable for running at any angle
- Built-in silent action electro-thermal shutter cassette
- Passive tricklevent facility for background ventilation with fan Off
- Easy clean high gloss ABS housing with integral finger safety guard
- Shadow grey external grille for unobtrusive external appearance
- Tamperproof internal connection safety plug and socket
- Unique metal ladderstrip / screw connection to external grille for security and weather tight seal

## Controllers

### Single Fan Controller FR22/30

Ref. 21868AW

- For use with GX9 and GX12
- On/Off control with neon indicator. Used to select between high and low speed, intake and extract

### Group Fan Controller EC6H

Ref. 21854AW

- For use with GX9 and GX12
- On/Off control with neon indicator. Infinitely variable speed selection controls extract and intake air flow. For use with up to four fans (not mixed sizes)

### Group Fan Controller XCC1

Ref. 21859AW

- For use with GX9 and GX12
- On/Off control with neon indicator



**Typical Specifications** on page 133.  
**Wiring Diagrams** on page 145.

## Performance

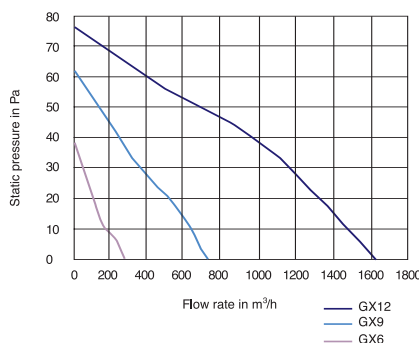

## Dimensions

### GX6

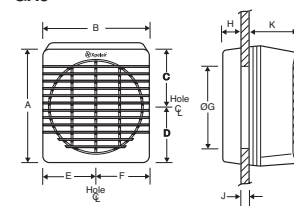

### GX9, GX12

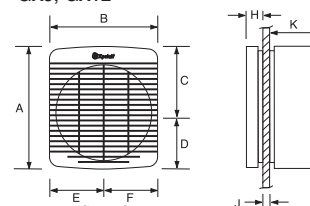

Model	Dimensions (mm)										
	A	B	C	D	E	F	G	H	J	K	
<b>GX6</b>	226	210	119	107	109	101	184/203	32	4-25	112	
<b>GX9</b>	312	294	165	147	147	147	257/266	32	4-25	117	
<b>GX12</b>	408	380	216	192	190	190	324/330	34	4-25	161	

## Installation and Accessories

The **GX6**, **GX9** & **GX12** ranges come complete with a universal mounting kit for window installations.

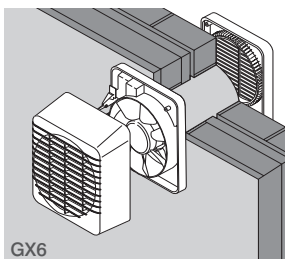

Wall Mounting

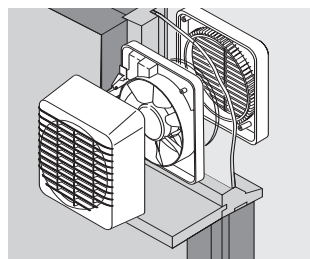

Window Mounting

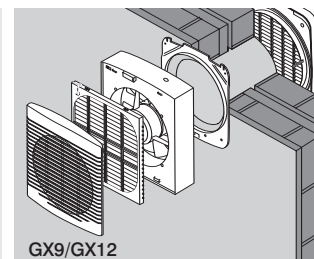

Wall Mounting

GX9 unit can be used for a variety of medical and photographic applications where light protection is required by replacing the external grille with a Darkroom Cowl.

Darkroom installation

Hole diameter: 203mm

Hole diameter: 184mm (GX6)  
257mm (GX9)  
324mm (GX12)

Hole diameter: 266mm (GX9)  
330mm (GX12)

### Installation Accessories

### Installation Accessories

### Installation Accessories

Wall Kit Ref. 89370AA

Wall Kit Ref. 89372AA (GX9)  
Wall Kit Ref. 89374AA (GX12)

Darkroom Cowl DC9 Ref. 98409AK

# Xpelair WX6, WX9 & WX12

## Commercial wall fans



### Key features

Type:	<b>Commercial duty ventilation unit</b>
Application:	<b>Pubs, restaurants, offices, kitchens, factories, schools and shops</b>
Control options:	<b>Extensive range of optional controllers available</b>
Legislation:	<b>Conforms to Building Regulations</b>



### The Range

Xpelair **WX** ventilation units – the ‘classic’ face of commercial wall fans. Discreetly slim, tough and reliable within – a winning formula that has served generations of pubs, businesses and local authorities.

Stylish commercial duty unit ventilation designed for pubs, restaurants, offices, kitchens, factories, schools and shops. Suitable for single, cavity brick and current timber frame walls.

The wall hugging, low profile white fascia is styled to blend in cleanly with commercial surroundings. For safety, a finger guard is integrated into the Ultra slim high gloss ABS fascia and the exterior wall grille design. On **WX9** & **WX12** units a positive plug and socket assembly provides a means of isolation for service access without the safety risk of accidental disconnection.

All WX models come complete with a wall mounting kit which include a wall liner.

Both the **WX9** & **WX12** are reversible and now feature totally enclosed external rotor motors providing constant volume outputs, even in gusty external conditions. Pre-balanced sickle bladed impellers eliminate ‘fan judder’ and ensure quiet trouble free operation. Sealed for life maintenance free bearings ensure suitability for running at any angle. Running costs are impressively low, and when not in use the silent electro-thermal shutter cassette closes silently against backdraughts. And cleaning has never been easier. The housing, shutter cassette and impeller are all removed in seconds.

### Select the right product for your application

	WX6	WX6T	WX9	WX12
Reference number	90822AW	90823AW	89996AW	90011AW
Remote switch (not supplied)	■	■	■	■
Integral adjustable run-on timer (2 to 20 mins)		■		
Extract only	■	■		
Selectable intake, extract or controller operation			■	■
Speeds	1	1	2*	2*
Extract performance (FID, m <sup>3</sup> /h)	high low	246	246	783 1715
Extract performance (FID, l/s)	high low	68	68	663 645
Intake performance (FID, m <sup>3</sup> /h)	high low			248 184
Intake performance (FID, l/s)	high low			477 437
Sound pressure level (dB(A)@3m)	high low	39	39	133 121
Electrical power rating (W)		34	34	50 47
Weight (kg)		34	34	41 85
Hole size (H x W mm)		2.9	2.9	4.7 8.3
Max wall thickness (mm)		268x245	268x245	375x345 434x434
Guarantee (years, UK)		292	292	508 522
		3	3	3 3

\*low speed only applies if fan used with FR22/30 controller. If controller not used fan is only single (high) speed

## Models

### WX6

Ref. 90822AW

- 6" high performance extract axial ventilation unit
- Suitable for single, cavity brick and current timber frame walls
- Sealed for life maintenance free bearings, suitable for running at any angle. Integrated safety thermal overload protection
- Built-in silent action electrothermal shutter cassette
- Passive tricklevent facility for background ventilation with fan Off
- Ultra slim high gloss ABS facia with integral finger safety guard
- Shadow grey external grille for unobtrusive external appearance with built-in weather protection

### WX6T

Ref. 90823AW

- As WX6 with overrun timer which typically connects to a lighting circuit
- Timer adjustable from 2-20mins run on period after light has been switched off

### WX9

Ref. 89996AW

### WX12

Ref. 90011AW

- High performance intake/extract axial ventilation unit
- Choice of optional controllers
- Suitable for single, cavity brick and current timber frame walls
- Balanced external rotor motor and impeller for quiet efficiency
- Sealed for life maintenance free bearings, suitable for running at any angle
- Built-in silent action electro-thermal shutter cassette
- Passive tricklevent facility for background ventilation with fan Off
- Ultra slim high gloss ABS facia with integral finger safety guard
- Shadow grey external grille for unobtrusive external appearance with built-in weather protection
- Tamperproof internal connection safety plug and socket

**Typical Specifications** on page 133.  
**Wiring Diagrams** on page 146.

## Controllers

### Single Fan Controller FR22/30

Ref. 21868AW

- For use with WX9 and WX12
- On/Off control with neon indicator. Used to select between high and low speed, intake and extract

### Group Fan Controller EC6H

Ref. 21854AW

- For use with WX9 and WX12
- On/Off control with neon indicator. Infinitely variable speed selection controls extract and intake air flow. For use with up to four fans (not mixed sizes)

### Group Fan Controller XCC1

Ref. 21859AW

- For use with WX9 and WX12
- On/Off control with neon indicator



## Performance

### WX6/T

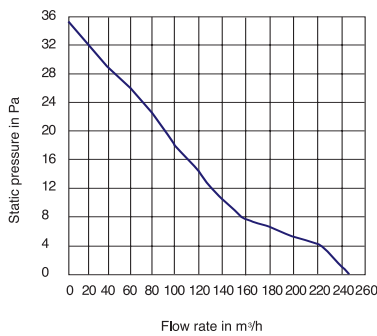

### WX9, WX12

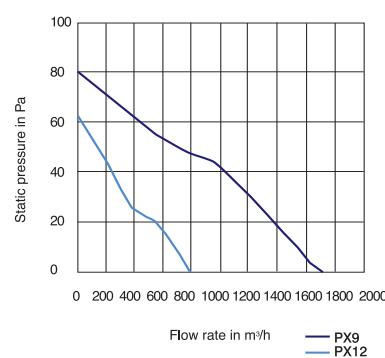

## Dimensions

### WX6/T

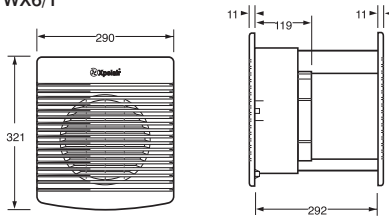

### WX9

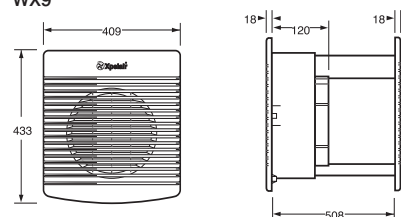

### WX12

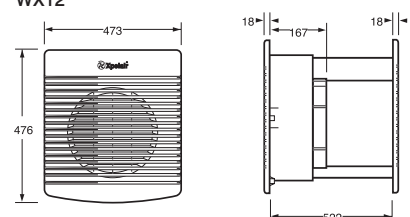

## Installation

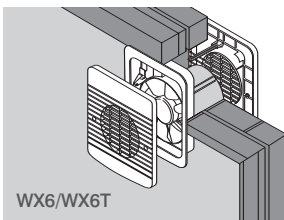

WX6/WX6T

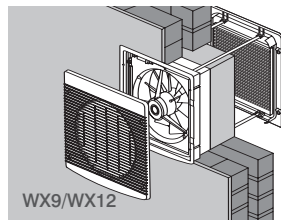

WX9/WX12

### Wall Mounting

Hole size (HxW): 268 x 245mm

### Wall Mounting

Hole size (HxW): 375 x 345mm (WX9)  
434 x 434mm (WX12)

# Xpelair PX6, PX9 & PX12

## Commercial ceiling fans



### Key features

Type:	<b>Commercial duty ceiling and panel mount axial ventilation unit</b>
Application:	<b>Kitchens, restaurants, pubs, offices, schools, shops and kiosks</b>
Control options:	<b>Extensive range of optional controllers available</b>
Legislation	<b>Conforms to Building Regulations</b>



### The Range

Introducing a new addition to the Xpelair commercial range. The **PX** range introduces even greater flexibility into the design of commercial and larger domestic ventilation systems. Based on the proven WX range, **PX** fans are perfect for ceiling and panel applications in kitchens, restaurants, pubs, offices, schools, shops and kiosks.

They can be installed at any angle in ceilings, voids and wall panels of any thickness. The ceiling hugging, low profile white fascia is styled to blend into any ceiling type, whether smooth, tiled or textured. For safety, a finger guard is integrated into the ultra slim high gloss ABS fascia. An integral spigot allows the attachment of flexible ducting, such as XFlex. Installation in ceilings and wall panels is rapid thanks to the concealed fixing points provided. Both the **PX9 & PX12**

are reversible making them ideal for ducted input systems in the hospitality industry. On **PX9 & PX12** units a positive plug and socket assembly provides a means of isolation for service access without the safety risk of accidental disconnection.

**PX9 & PX12** models feature totally enclosed external rotor motors providing constant volume outputs, even in gusty external conditions. Pre-balanced sickle bladed impellers eliminate 'fan judder' and ensure quiet trouble free operation. Sealed for life maintenance free bearings ensure suitability for running at any angle. Running costs are impressively low, and when not in use the silent electro-thermal shutter cassette closes silently against backdraughts. Installation has never been easier. The housing, shutter cassette and impeller are all removed in seconds.

### Select the right product for your application

	PX6	PX9	PX12
Reference number	91300AW	91299AW	91298AW
Remote switch (not supplied)	■	■	■
Extract only	■		
Selectable intake, extract or controller operation		■	■
Speeds	1	2*	2*
Extract performance (FID, m³/h)	high low	246 685	1712 646
Extract performance (FID, l/s)	high low	68 190	476 179
Intake performance (FID, m³/h)	high low	458 433	1037 845
Intake performance (FID, l/s)	high low	127 120	288 235
Sound pressure level (dB(A)@3m)	high low	39 50 47	54 48
Ducting size (mm)	200	250	315
Electrical power rating (W)	34	41	85
Weight (kg)	2.8	4.7	7.9
Hole size (H x W mm)	268x245	375x345	434x434
Spigot size (mm)	200	250	315
Guarantee (years, UK)	2	2	2

\*low speed only applies if fan used with FR22/30 controller. If controller not used fan is only single (high) speed

## Models

### PX6

#### Ref. 91300AW

- High performance extract only axial flow ventilation unit
- Operated by remote On/Off switch (not supplied)
- Suitable for installation at any angle in ceilings, voids and wall panels of any thickness
- Totally enclosed motor
- Sealed for life maintenance free bearings, suitable for running at any angle
- Built in silent action electrothermal shutter cassette
- Ultra slim high gloss ABS fascia with integral safety finger guard

### PX9

#### Ref. 91299AW

- High performance intake / extract axial flow ventilation unit
- Choice of optional controllers
- Suitable for installation at any angle in ceilings, voids and wall panels of any thickness
- Balanced external rotor motor and sickle

impeller for quiet efficiency

- Sealed for life maintenance free bearings, suitable for running at any angle
- Built in silent action electrothermal shutter cassette
- Ultra slim high gloss ABS fascia with integral safety finger guard

### PX12

#### Ref. 91298AW

- High performance intake / extract axial flow ventilation unit
- Choice of optional controllers.
- Suitable for installation at any angle in ceilings, voids and wall panels of any thickness
- Balanced external rotor motor and sickle impeller for quiet efficiency
- Sealed for life maintenance free bearings, suitable for running at any angle
- Built in silent action electrothermal shutter cassette
- Ultra slim high gloss ABS fascia with integral safety finger guard

## Controllers

### Single Fan Controller FR22/30

#### Ref. 21868AW

- For use with PX9 and PX12
- On/Off control with neon indicator. Used to select between high and low speed, intake and extract

### Group Fan Controller EC6H

#### Ref. 21854AW

- For use with PX9 and PX12
- On/Off control with neon indicator. Infinitely variable speed selection controls extract and intake air flow. For use with up to four fans (not mixed sizes)

### Group Fan Controller XCC1

#### Ref. 21859AW

- For use with PX9 and PX12
- On/Off control with neon indicator



**Typical Specifications** on page 134.  
**Wiring Diagrams** on page 146.

## Performance

### PX6

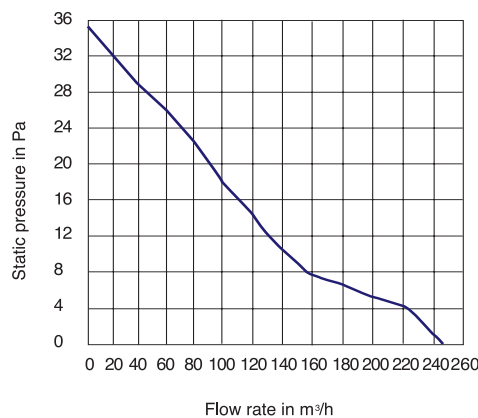

### PX9, PX12

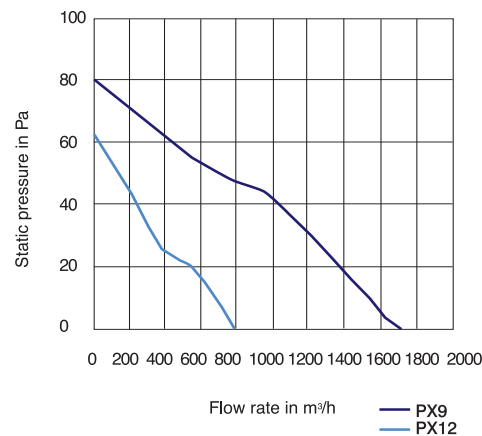

## Dimensions

### PX6

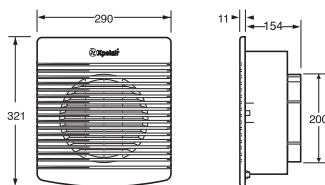

### PX9

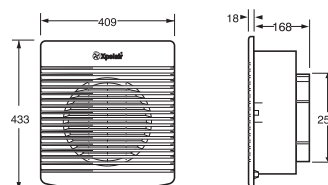

### PX12

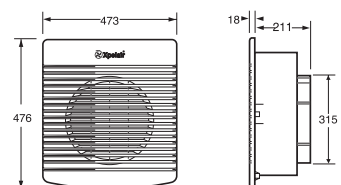



# Xpelair RX6, RX9 & RX12

## Commercial roof fans



### Key features

Type: **Commercial duty roof mount axial ventilation unit with roof cowl**

Application: **Pubs, restaurants, offices, kitchens, factories, squash courts, schools and shops**

Control options: **Extensive range of optional controllers available**

Legislation: **Conforms to Building Regulations**



### The Range

With commercial wall space at a premium, sometimes the only way is up!

Xpelair **RX** models are a neat way of ventilating through glazed and solid roofs and can be used vertically in windows on exposed sites such as coastal areas and high rise buildings. The commercial duty roof fans are particularly suitable for pubs, restaurants, offices, kitchens, factories, and squash courts, schools in areas like changing rooms, and kiln rooms and a wide range of shops.

The contoured high gloss white housing is sleekly styled. For safety, a finger guard is integrated into the ultra slim high gloss ABS fascia. The UV stabilised roof cowl assembly is a generous size to provide weather protection at all angles. They are suitable for single and sealed double glazed windows and panels up to 25mm. Installation in wire cast and sealed double glazed roof lights is rapid using Xpelair's unique metal ladderstrip and screw system, ensuring a secure and weather-

tight compression seal. For flat roofs an optional roof mounting plate allows **RX** models to be fitted to dressed curbs.

Both the **RX9** & **RX12** are reversible. All models offer a passive trickle vent option for background ventilation when the fan is off. On **RX9** & **RX12** units a positive plug and socket assembly provides a means of isolation for service access without the safety risk of accidental disconnection.

**RX9** & **RX12** models feature totally enclosed external rotor motors providing constant volume outputs, even in gusty external conditions. Pre-balanced sickle bladed impellers eliminate 'fan judder' and ensure quiet trouble free operation. Sealed for life maintenance free bearings ensure suitability for running at any angle. Running costs are impressively low, and when not in use the silent electro-thermal shutter cassette closes silently against backdraughts. And cleaning has never been easier. The housing, shutter cassette and impeller are all removed in seconds.

### Select the right product for your application

		RX6	RX9	RX12
Reference number		90818AW	90424AW	90425AW
Remote switch (not supplied)		■	■	■
Extract only		■		
Selectable intake, extract or controller operation			■	■
Speeds		1	2*	2*
Extract performance (FID, m <sup>3</sup> /h)	high	206	511	1100
	low		430	807
Extract performance (FID, l/s)	high	57	142	306
	low		119	224
Intake performance (FID, m <sup>3</sup> /h)	high		438	915
	low		384	709
Intake performance (FID, l/s)	high		122	254
	low		107	197
Sound pressure level (dB(A)@3m)	high	39	52	56
	low		49	48
Electrical power rating (W)		35	41	87
Weight (kg)		3.8	4.5	7.9
Hole size (H x W mm)		184	257	324
Max wall thickness (mm)		25	25	25
Guarantee (years, UK)		3	3	3

\*low speed only applies if fan used with FR22/30 controller. If controller not used fan is only single (high) speed

## Models

### RX6

Ref. 90818AW

- High performance extract only axial flow ventilation unit
- Operated by remote On/Off switch (not supplied)
- Suitable for single and sealed double glazed windows and panels up to 25mm
- Built in electrothermal shutter cassette
- Passive trickle vent option for background ventilation with fan Off
- Easy clean high gloss ABS housing
- Roof cowl assembly in UV stabilised material provides weather protection at all roof angles
- Unique metal ladderstrip/screw connection to external grille for security and weathertight seal
- Supply voltage 220-240V 50Hz

### RX9

Ref. 90424AW

- As RX6
- High performance intake/extract axial flow ventilation unit
- Choice of optional controllers
- Tamper-proof internal connection safety plug and socket

### RX12

Ref. 90425AW

- As RX9

**Typical Specifications** on page 134.  
**Wiring Diagrams** on page 146.

## Controllers

### Single Fan Controller FR22/30

Ref. 21868AW

- For use with RX9 and RX12
- On/Off control with neon indicator. Used to select between high and low speed, intake and extract

### Group Fan Controller EC6H

Ref. 21854AW

- For use with RX9 and RX12
- On/Off control with neon indicator. Infinitely variable speed selection controls extract and intake air flow. For use with up to four fans (not mixed sizes)

## Performance

### RX6 Range

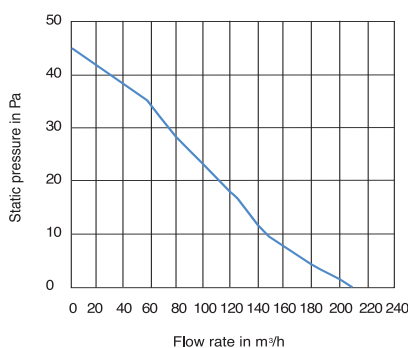

### RX9, RX12 Range

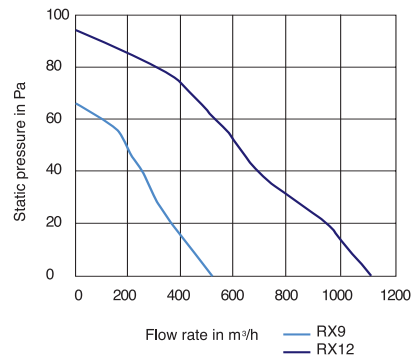

## Dimensions

### RX Range

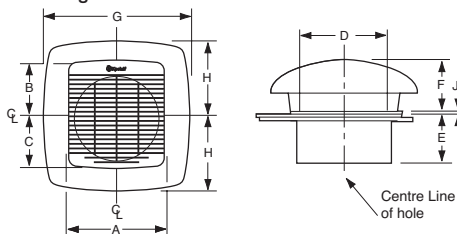

Model	Dimensions (mm)								
	A	B	C	D	E	F	G	H	J
RX6	210	119	107	184	112	127	319	160	4/25
RX9	312	165	147	257	117	159	438	219	4/25
RX12	380	216	192	234	161	197	554	277	4/25

## Installation and Accessories

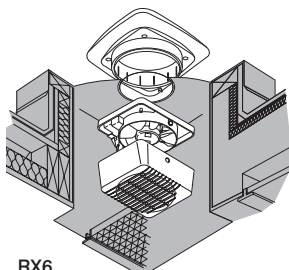

### RX6

Kerb Mounting

Hole diameter: 184mm

### Installation Accessories

Roof Mounting Plate Ref. 00370AK  
Kerb detail see **commercial accessories** on page 79

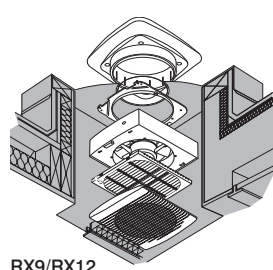

### RX9/RX12

Kerb Mounting

Hole diameter: 257mm (RX9)  
324mm (RX12)

### Installation Accessories

Roof Mounting Plate Ref. 00371AK  
Kerb detail see **commercial accessories** on page 79



### Key features

Type:	<b>Professional kitchen extract</b>
Application:	<b>Kitchen extract</b>
Control options:	<b>Electronic/Transformer speed control</b>
Legislation	<b>Building Regulations</b>



### The Range

A range of kitchen canopies designed for small professional catering and institutional applications.

Suitable for pub food preparation and wash up areas, club kitchens, cafeterias, fast food outlets, smaller commercial kitchens staff kitchenettes, student block kitchens, and a range of commercial applications.

**ChefX** canopies are an all in one solution to a range of standard commercial duty kitchen applications. Built to a professional specification. **ChefX** are designed for continuous heavy use and a more demanding environment.

The three models in the range are manufactured complete with commercial duty filters and built in high pressure centrifugal fans allowing direct discharge to atmosphere or connection to ductwork.

When specifying, as a general guide, the hood should protrude outwards approximately 200mm beyond the working surface with the bottom of the hood 1900mm – 2000mm from the floor.

### Select the right product for your application

	Tempo	Presto	Mezzo
Reference number	91309AA	91310AA	91311AA
Width (mm)	600	1000	1000
Air delivery (m <sup>3</sup> /h@100Pa)	400	2200	2800
Electrical power rating (W)	100	830	940
Electrical current rating (A)	0.45	3.8	4.4
Weight (kg)	6.5	44	43
Washable mesh filters	■	■	■
Guarantee (years, UK)	2	2	2

## Models

### ChefX Tempo Ref. 91309AA

- Robust design for institutional applications such as student block kitchens and staff rest room food preparation areas
- Brushed stainless steel housing
- 400m<sup>3</sup>/h extraction capacity @100Pa
- Washable G.S.M mesh filters
- Built in lighting - 1 x 11W CFL
- Top LH outlet
- Built in isolator and speed control with 'on' light
- Centrifugal fan / scroll assembly

### ChefX Presto Ref. 91310AA

- For cafeterias, fast food outlets, food preparation and wash up areas
- Stainless steel housing with G.S.M support components
- 2200m<sup>3</sup>/h extraction capacity @100Pa
- Washable 25mm G.S.M mesh filters

- Top centre outlet to accept rectangular or circular ductwork
- Centrifugal double inlet fan and scroll assembly
- Speed controllable motor
- IPX4 rated motor
- Max ambient temp 65°C

### ChefX Mezzo Ref. 91311AA

- Higher duty model for cafeterias, fast food outlets, food preparation and wash up areas
- Stainless steel housing with G.S.M support components
- 2800m<sup>3</sup>/h extraction capacity @100Pa
- Washable 25mm baffle filters
- Top centre outlet to accept rectangular or circular ductwork
- Centrifugal double inlet fan and scroll assembly
- Speed controllable motor.
- IPX4 rated motor
- Max ambient temp 65°C

## Controllers

### Electronic Speed controller XCW1.6 Ref. 90408AW

- Compatible with Presto and Mezzo models. Provides On/Off operation with variable speed control.

### Five step auto transformer Ref. 91369AA

- Compatible with Presto and Mezzo models. 6 Amp transformer providing five speed operation. Robust ISO casing and IPX4 rated.

**Wiring Diagrams** on page 146.

## Performance

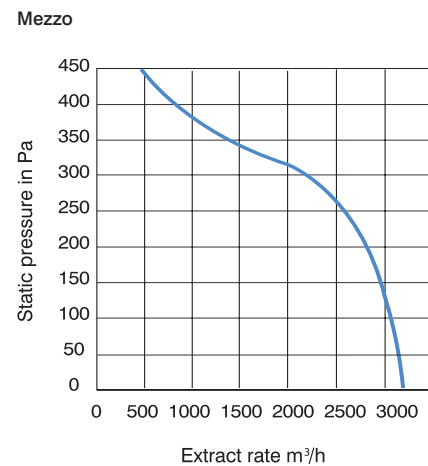
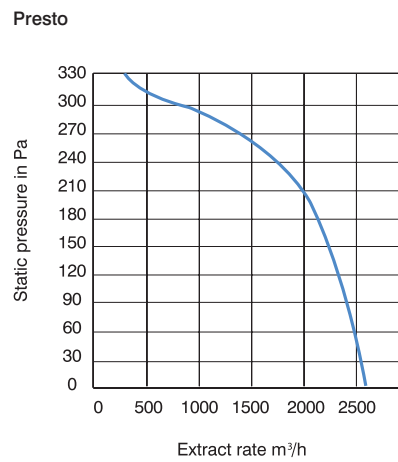
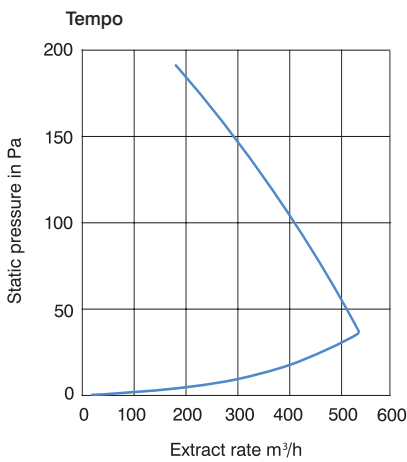

## Dimensions

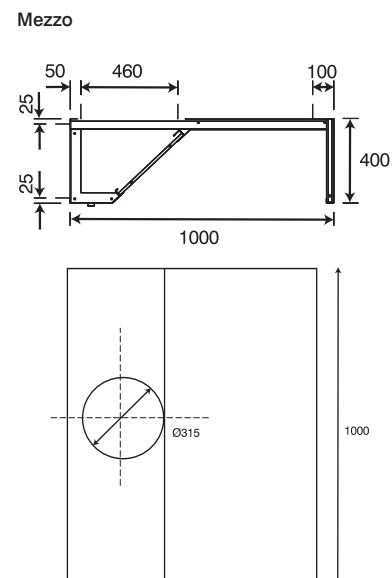
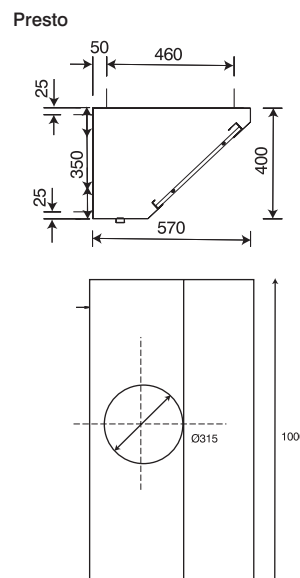
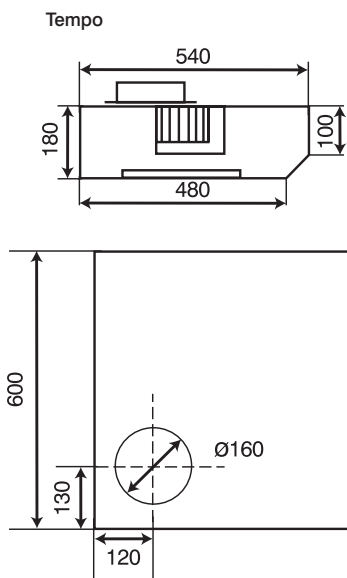

# Xpelair Commercial Sensors and Switches



## Single Fan Controller FR22/30

### Ref. 21868AW

- Sliding switches
- On/Off
- 2 speeds: low- high speed
- Extract - intake airflow
- Power 'on' indicator
- For surface or recess mounting
- 208 x 86 mm
- Supply voltage: 220 -240V 50Hz
- Gloss white
- Use with: GX9, GX12, WX9, WX12, PX9, PX12, RX9, RX12



## Single Direction Group Fan Controller XCC1

### Ref. 21859AW

- Sliding switches and speed control knob
- On/Off
- Infinitely variable speed control
- Single direction: extract or intake selected at installation
- Power 'on' indicator
- For surface or recess mounting
- 160 x 68mm
- Supply voltage: 220 - 240V 50Hz
- Gloss White
- Use with: GX9, GX12, WX9, WX12, PX9, PX12, RX9, RX12

Note: do not mix fan size. For use with up to 4 - size 12 or 6 -size 9 fans units.



## Reversible Group Fan Electronic Controller EC6H

### Ref. 21854AW

- Sliding switches and speed control knob
- On/Off
- Infinitely variable speed control
- Extract - intake airflow
- Power 'on' indicator
- For surface or recess mounting
- 160 x 68mm
- Supply voltage: 220 - 240V 50Hz
- Gloss White
- Use with: GX9, GX12, WX9, WX12, PX9, PX12, RX9, RX12

Note: do not mix fan size. For use with up to 4 - size 12 or 6 -size 9 fans units.



## Remote Humidistat XRH

### Ref. 21856AW

- Stand alone humidistat switches on when RH rises to preset level and Off when it declines
- Fan operation indicator light
- Pullcord operated override switch
- Surface or recess mounting
- 160 x 86mm
- White finish
- Supply voltage 220 - 240V 50Hz
- Use with: GX6, GX9, GX12, WX6, WX9, WX12, PX6, PX9, PX12, RX6, RX9 & RX12



## Time Controller DT20B

### Ref. 21850AW

- Usually connected to the lighting circuit. Fan switches On with the light. Provides continued ventilation run-on period after the light has been switched off
- User adjustable up to 20min
- Surface or recess mounting
- White finish
- Supply voltage 220-240V 50Hz
- 100 x 86mm
- Use with: GX6, GX9, GX12, WX6, WX9, WX12, PX6, PX9, PX12, RX6, RX9 & RX12

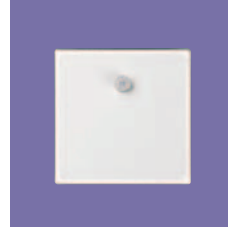

## Passive Infrared Sensor XPIRA

### Ref. 21871AA

- Position to switch the fan on when body movement is detected. Ideal for infrequently used public spaces
- Built in run on timer to avoid nuisance tripping
- For indoor use only
- 86 x 86 mm
- Use with: GX6, GX9, GX12, WX6, WX9, WX12, PX6, PX9, PX12, RX6, RX9 & RX12



## Controller HC301

### Ref. 21877AW

- On/Off switch
- Fan only/fan and heater options
- Variable thermostatic control
- Suitable for surface or recessed installation
- 208 x 86mm
- Colour: White
- Used with WH30 and WHP30



### GX Wall Kits WK

WK6/8	200mm (GX6)	Ref. 89369AA
WK6/11	280mm (GX6)	Ref. 89370AA
WK9/8	200mm (GX9)	Ref. 89371AA
WK9/11	280mm (GX9)	Ref. 89372AA
WK12/8	200mm (GX12)	Ref. 89373AA
WK12/11	280mm (GX12)	Ref. 89374AA

- For bridging cavity walls and lining double brick walls
- Steel wall liner
- Length: 200mm and 280mm
- Set of 508mm ladder strips

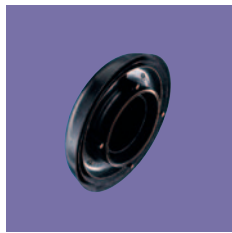

### Darkroom Cowl DC9 Ref. 98409AK

- For use in scientific and photographic applications
- Replaces the outer grille on GX9 and GXC9 models
- Roof, window or wall mounting
- Colour: black
- Use with: GX9, GXC9

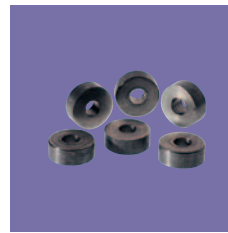

### Distance Piece GXDP Ref. 56708AA

- Allows GX units to be fixed to distorted walls of 38mm minimum thickness
- By spacing the fan unit and outer grille away from the wall or panel, distortion through over tightening is prevented
- Set of 6

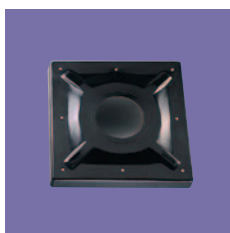

### Roof mounting plates XRP

XRP6 (RX6)	Ref. 00370AK
XRP9 (RX9)	Ref. 00371AK
XRP12 (RX12)	Ref. 00371AK

- Provides effective and secure installation in flat roof applications
- Flame retardant resin bonded fibre glass.
- Requires the installer to build a kerb onto which plate is fixed. Always use sealant to bed in the outer cowl seal for weatherproof joint
- Colour black

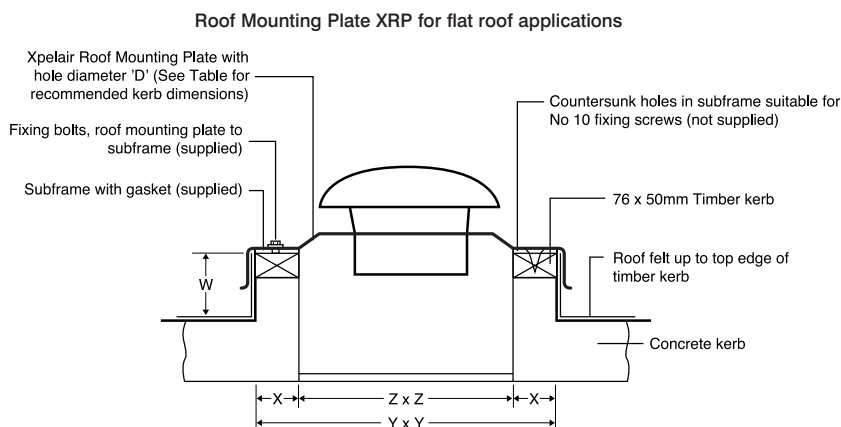

Apply suitable sealing compound between roof mounting plate, subframe, timber kerb and concrete kerb

Model	Dimensions (mm)				
	W(min)	X	Y	Z	D hole
<b>RX6</b>	152	76	527	375	184
<b>RX9</b>	152	76	711	559	257
<b>RX12</b>	152	76	711	559	324



### GX Longer Length Ladder Strips GXL

GXL20	20 pack	Ref. 89382AA
GXL50	50 pack	Ref. 89383AA

- Used when installing GX fans through walls
- Length 508mm
- Easy to cut
- GX6 & GXC6 2 strips
- GX9 & GXC9 3 strips
- GX12 4 strips

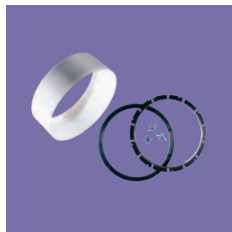

### Double Window Kit GXDW

GXDW6 (GX6 & GXC6)	Ref. 98229AA
GXDW9 (GX9 & GXC9)	Ref. 98228AA
GXDW12 (GX12)	Ref. 98227AA

- For hinged double windows only
- For installation of GX fans into separate double windows spaced between 32mm and 102mm
- Allows inner casement window to be opened without dismantling the fan

# Xpelair Commercial Accessories



## Air-Replacement Grilles ARG

ARG20	200 x 200 mm	Ref. 89833AA
ARG30	300 x 300 mm	Ref. 89834AA

- For use with all commercial fans
- Fitted to doors or partition walls to provide adequate air replacement for a fan
- Can be used in conjunction with FIRE BLOCK FB in fire doors and panels to prevent the breach of protected areas or compartments
- Each set comprises 2 grilles

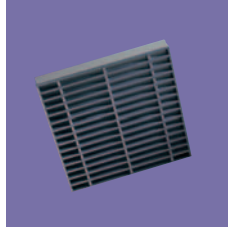

## Fire Block FB

FB20	200 x 200 mm	Ref. 89835AA
FB30	300 x 300 mm	Ref. 89836AA

- For use with air replacement grille (ARG)
- Fitted between two grilles in a fire door or compartment
- Spec fire rated 60 mins to BS478 Part 8

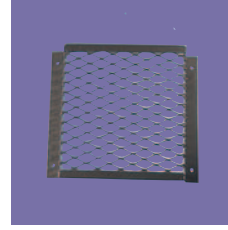

## Protective Wall Grille PG

PG6	(GX6, GXC6, WX6)	Ref. 89375AA
PG9	(GX9, GXC9, WX9)	Ref. 89376AA
PG12	(GX12)	Ref. 89377AA
PGW12	(WX12)	Ref. 90294AA

- For use with GX and WX fans to protect the exterior grille from damage by vandals
- Constructed from steel mesh and finished in black epoxy powder paint
- Surface mounted to exterior wall using fixing screws and wall plugs provided



## Flexible Ducting Xflex FD

	Dia	Length	
FD100	100mm	3m	Ref. 89663AA
		4.5m	Ref. 89910AA
		6m	Ref. 89669AA
FD125	125mm	3m	Ref. 89664AA
		6m	Ref. 89670AA
<b>Commercial Diameters</b>			
FD150	150mm	3m	Ref. 89665AA
		6m	Ref. 89671AA
FD200	200mm	3m	Ref. 89666AA
		6m	Ref. 89672AA
FD250	250mm	3m	Ref. 89667AA
		6m	Ref. 89673AA
FD315	315mm	3m	Ref. 89668AA
		6m	Ref. 89674AA

- Glass fibre fabric on a PVC coated close pitch steel wire helix. 54 minute fire integrity from within as measured to BS 476: Part 20 - (1987)
- Can be interlocked and sealed with duct tape to form an airtight seal
- Attached to spigots using worm drive clips



## New Aluminium Flexible Ducting Xflex ALU

	Dia	Length	
ALU100	100mm	10m	Ref. 91435AA
ALU125	125mm	10m	Ref. 91436AA
ALU150	150mm	10m	Ref. 91437AA
<b>Commercial Diameters</b>			
ALU200	200mm	10m	Ref. 91438AA
ALU250	250mm	10m	Ref. 91439AA
ALU315	315mm	10m	Ref. 91440AA
ALU400	400mm	10m	Ref. 91441AA

- Tough foil construction on a high strength wire helix
- Over 40 minute fire rating BS 476: Part 20 (1987)



## Thermal Flexible Ducting Xflex TFD

	Dia	Length	
TFD100	100mm	5m	Ref. 89847AA
		10m	Ref. 91459AA
TFD125	125mm	5m	Ref. 89848AA
		10m	Ref. 91460AA
TFD150	150mm	5m	Ref. 89849AA
		10m	Ref. 91461AA
<b>Commercial Diameters</b>			
TFD200	200mm	5m	Ref. 89850AA
		10m	Ref. 91462AA
TFD250	250mm	5m	Ref. 89851AA
		10m	Ref. 91463AA
TFD315	315mm	5m	Ref. 89852AA
		10m	Ref. 91464AA

- Double skinned insulated aluminium duct with high density fibreglass insulation to minimise condensation formulation
- 25 minute fire integrity from within as measured to BS 476: Part 20 - (1987)
- Can be interlocked and sealed with duct tape to form an airtight seal
- Attached to spigots using worm drive clips



### Worm Drive Clips WDC

Dia

WDC5 100 -125mm	Ref. 89684AA
WDC8 150 - 200mm	Ref. 89685AA
WDC13 250 - 315mm	Ref. 89686AA

- Steel clips for connecting flexible ductwork to spigots.
- Supplied in packs of 10

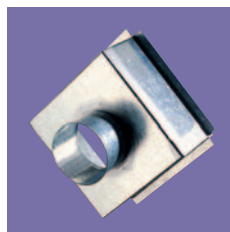

### Grille Box GB

Duct Dia Square

GB20/100	100mm	200mm	Ref. 89676AA
GB20/125	125mm	200mm	Ref. 89677AA
GB20/150	150mm	200mm	Ref. 89678AA
GB30/200	200mm	300mm	Ref. 89679AA
GB30/250	250mm	300mm	Ref. 89680AA
GB45/315	315mm	450mm	Ref. 89681AA
GB50/315	315mm	500mm	Ref. 89828AA
GB60/315	315mm	600mm	Ref. 90296AA

- Used in conjunction with egg-crate ceiling grille and ceiling diffuser grille to connect to ductwork
- Use Xflex FD or TFD to attach to spigot and secure with worm drive dip



### Spigot Plates SP

Duct Dia Square

SP100	100mm	180mm	Ref. 89697AA
SP125	125mm	175mm	Ref. 89698AA
SP150	150mm	200mm	Ref. 89699AA
SP200	200mm	250mm	Ref. 89700AA
SP250	250mm	300mm	Ref. 89701AA
SP315	315mm	365mm	Ref. 89702AA

- Fixes to the interior surface of wall to connect to Xflex ducting
- Connect duct using worm drive clips
- Material: plastic

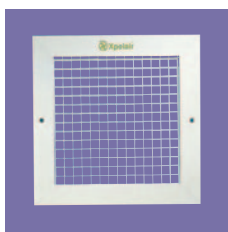

### Egg-Crate Ceiling Grilles CG

	Square	SATIN SILVER
CG20	200mm	Ref. 89675AA
CG30	300mm	Ref. 89532AA
CG45	450mm	Ref. 89533AA
CG50	500mm	Ref. 89827AA
CG60	600mm	Ref. 90295AA
	Square	WHITE
CG20	200mm	Ref. 89823AW
CG30	300mm	Ref. 89824AW
CG45	450mm	Ref. 89825AW
CG50	500mm	Ref. 89826AW

- Can be used on ceilings or internal walls as an air replacement grille with large free area
- Aluminium construction
- Fixing screws provided (not size 600)
- Use with grille boxes and Xflex ducting
- Colours: Satin silver or white



### Ceiling Diffuser Grilles DG

	Square	SATIN SILVER
DG20	200mm	Ref. 89816AA
DG30	300mm	Ref. 89818AA
DG45	450mm	Ref. 89820AA
DG50	500mm	Ref. 89822AA
DG60	600mm	Ref. 90292AA
	Square	WHITE
DG20	200mm	Ref. 89815AW
DG30	300mm	Ref. 89817AW
DG45	450mm	Ref. 89819AW
DG50	500mm	Ref. 89821AW
DG60	600mm	Ref. 90603AW

- For air input systems terminating at ceilings and internal walls
- Adjustable grille vanes to set up direction of airflow for a particular area
- Fixing screws provided (not size 600)
- Use with grille boxes and Xflex ducting
- Aluminium construction
- Colours: Satin Silver or White

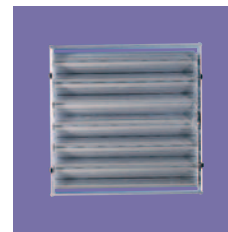

### Air Volume Dampers AVD

	Square	
AVD20	200mm	Ref. 89829AA
AVD30	300mm	Ref. 89830AA
AVD45	450mm	Ref. 89831AA
AVD50	500mm	Ref. 89832AA

- Clips directly to an eggcrate grille or ceiling diffuser grille to adjust the volume of air entering the room
- Lever adjustment
- Depth 44mm
- Used together with Grille Box and Xflex ducting
- Material: Aluminium Mill finish