

Bathroom and shower room fans for wall, window and ceiling installations

More moisture is produced in bathrooms than anywhere else in your home.

Bathrooms and shower rooms are relatively cool areas. Moisture from hot water in showering, bathing and washing is quickly absorbed into the air, which warms rapidly increasing further its capacity to hold water vapour. The hard surfaces of the bathroom – tiling, mirrors, painted surfaces and windows change temperature far more slowly and, being cooler than the air, form water droplets seen as ‘misted up’ mirrors and windows.

This warm ‘wet’ air quickly migrates to adjacent rooms condensing on cooler unventilated surfaces such as the back of wardrobes and increasing the humidity level throughout the house.

Matters can be aggravated if the room is also used for drying clothes.

Today, condensation problems like these are more commonplace as we shower

more and place greater emphasis on air tightness in our homes.

Toilets present a different problem. Unchecked, odours are unpleasant and embarrassing.

The solution is to extract moisture and odours at source. In bathrooms and toilets the most effective position is diagonally opposite the door allowing a gentle flow of air across the room. In showers, it is often best positioned directly over the shower cubicle.

Which solution is best for me?

IEE electrical regulations define bathrooms as areas of increased electrical hazard. The illustrations in the Bathroom Zoning section show the zones in which fans of differing IP rating can be installed. As a rule, look out for IPX4 or higher. For complete peace of mind Xpelair LoVolt models are available which have a separate Safety Extra Low Voltage transformer fitted outside of the splash area and operate the fan at 12V.

For installations that fall within the scope of Building Regulations the extract

requirements are 15 l/s for bathroom and shower rooms, and 6 l/s for toilets.

If the room does not have an opening window then a fan with a built in timer should be selected. This will continue to run for at least 15 minutes after the room has been vacated.

Axial fans are suitable for through the wall or window fitting in most homes. For high-rise and exposed (e.g. coastal) locations, centrifugal fans will cope better with gusty conditions. Centrifugal and mixed flow units have a better pressure characteristic, which makes them more suitable where a ducted solution is required. For showers, Xpelair offers kits for simple above ceiling extract ventilation through a soffit.

Air replacement is particularly important in these rooms as the doors are shut when occupied. A fan can only function if there is an equal flow of air to that being extracted. This can be achieved by maintaining a small gap beneath the door and the floor covering or by fitting a slim air replacement grille to the door.

Bathroom Product selector

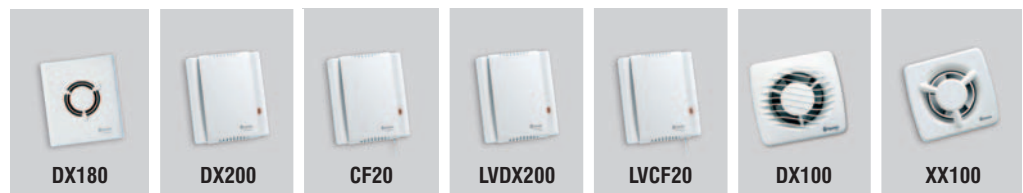

Page Number	10	10	10	12	12	14	14
Fan Type	Centrifugal	Centrifugal	Centrifugal	Centrifugal	Centrifugal	Axial	Axial
Voltage	230V	230V	230V	LoVolt	LoVolt	230V	230V
Positioning	Wall / Window	Wall / Window	Wall / Window	Wall / Window	Wall / Window	Wall / Window	Wall / Window
Max extract rate (m³/h)	94	108	108	108	108	76	76
IP rating	IPX4	IPX5	IPX5	IPX5	IPX5	IPX5	IPX5
Fan only or kit	Fan	Fan	Fan	Fan	Fan	Kit	Fan
Control Options							
Timer	■	■	■	■	■	■	■
Pullcord version		■	■		■	■	■
Humidistat version	■		■		■	■	

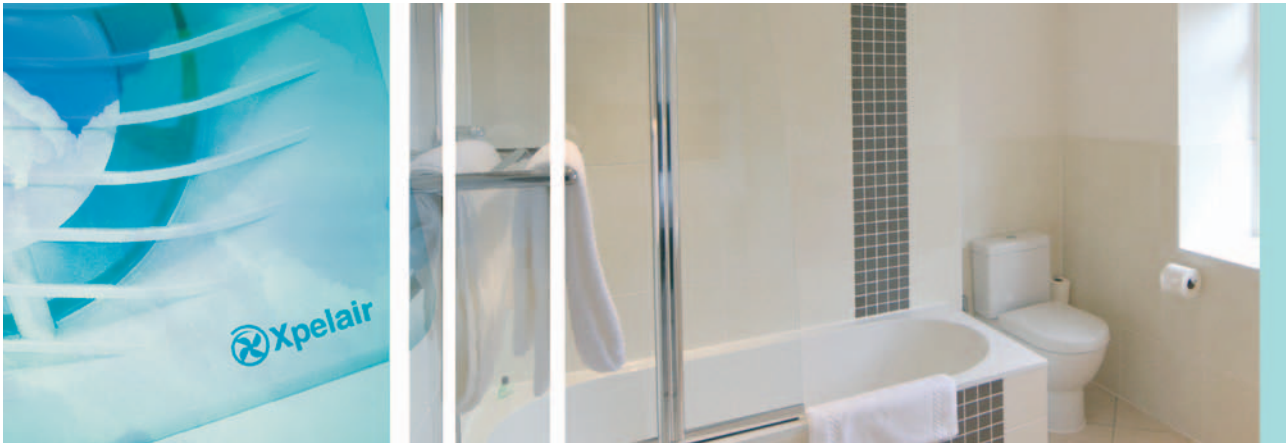

Brochure Builder

Allows you to create your own e-brochure. It is an invaluable tool for specification work or for e-mailing product information. For further details visit www.Xpelair.co.uk and follow the steps outlined below:

www.applied-energy.com



Click here to enter Brochure Builder.

www.Xpelair.co.uk



You can also click on the advertising banner to enter Brochure Builder on the Xpelair homepage.

Brochure Builder

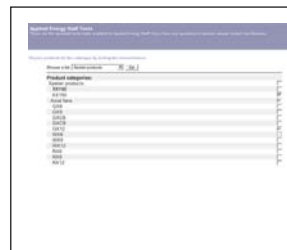

Once you have registered you are able to create your unique product brochure. Simply choose which brand/products you would like to include.

E-brochure



Once you have selected your products the electronic brochure is created so you can either print it yourself or e-mail to a customer.



	LV100	Slimline	CentrX	XIL	XXS	BriteX	BriteX Turbo	XIM
Page Number	16	18	20	22	22	24	24	28
Fan Type	Axial	Axial	Centrifugal	Axial	Axial	Axial	Mixed Flow	Mixed Flow
Voltage	LoVolt	230V	230V	230V	230V	LoVolt	LoVolt	230V
Positioning	Wall / Window	Wall / Window	Wall	Inline	Inline	Inline	Inline	Inline
Max extract rate (m ³ /h)	85	180	169	133	85	56	65	845
IP rating	IPX5	IPX4	IPX4	IPX2	IPX2	IPX4	IPX4	IPX2/4
Fan only or kit	Kit	Fan	Fan	Kit	Fan	Kit	Kit	Fan
Control Options								
Timer	■	■	■	■	■	■	■	■
Pullcord version	■	■	■					
Humidistat version	■	■	■					

Xpelair Premier DX180, DX200 & CF20

Centrifugal extract and condensation control fans



Key features

Type:	DX centrifugal extract and CF condensation control fans
Application:	Domestic bathrooms, shower rooms, toilets and utility rooms
Control options:	Pull cord, timer and humidistat
Legislation:	Conforms to Building Regulations
Hole size:	117mm (wall) 120mm (window)

The Range

The efficient and stylish Premier range of pressure developing fans is designed specifically for domestic applications, including bathrooms, shower rooms, toilets and utility rooms where longer duct runs are required. They are also suitable for commercial applications such as hotel rooms, office toilets, commercial bathrooms, and for coastal installations.

All models have a gloss white casing with clean and sleek appearance. A two part casing means Premier fans can easily be recessed or surface mounted. They can be fitted into ceilings or studwork walls in recesses as little as 50mm deep using the side entry knockout provided, an FDA adaptor and Profile 29 flat duct. Alternatively 100mm circular ducting can be used. All feature an automatic air

operated back draught shutter and the **CF20** range are supplied with a brown 100mm external outlet grille for wall or soffit fixing. All models come complete with a universal mounting kit.

The clip off front cover and removable fan blade on all models allow easy cleaning and maintenance. All also have a neon indicator (except DX180/T).

DX200 and **CF20** models are IPX5 rated where-as the **DX180** models are IPX4. All are BEAB approved. They are all suitable for 220-240Vac 50Hz mains operation. Motors are totally enclosed and maintenance free for life, with self aligning bearings and a thermal cut-out. All electronics and wiring terminals are fully protected.



Select the right product for your application

	DX180	DX180T	DX180H	DX200	DX200T	CF20	CF20T
Reference number	91181AW	91182AW	91183AW	91013AW	91014AW	91015AW	91016AW
Remote switch (supplied separately)	■	■		■	■		■
Integral pullcord						■	■
Integral adjustable run-on timer (30s to 20 mins)					■		■
Integral fixed run-on timer (20 mins)		■					
Humidity sensor (50-90% RH)			■			■	■
Quick visit facility (2 minutes)					■		■
Speeds	1	1	1	2	4	5	5
Trickle ventilation facility					■	■	■
Extract performance (FID, m³/h)							
boost	-	-	-	-	-	108	108
speed 3	-	-	-	-	108	102	102
speed 2	-	-	-	108	79	79	79
speed 1	94	94	94	50	50	50	50
trickle	-	-	-	-	36	36	36
Extract performance (FID, l/s)							
boost	-	-	-	-	-	30	30
speed 3	-	-	-	-	30	28	28
speed 2	-	-	-	30	22	22	22
speed 1	26	26	26	14	14	14	14
trickle	-	-	-	-	10	10	10
Sound pressure level (dB(A)@3m)							
boost	-	-	-	-	-	50	50
speed 3	-	-	-	-	50	48	48
speed 2	-	-	-	50	42	42	42
speed 1	49	49	49	32	32	32	32
trickle	-	-	-	-	26	26	26
Electrical power rating (W)	26	26	26	34	34	34	34
Weight (kg)	2.0	2.0	2.0	1.75	1.75	1.75	1.75
IP rating	IPX4	IPX4	IPX4	IPX5	IPX5	IPX5	IPX5
Guarantee (years, UK)	3	3	3	3	3	3	3

Models

Premier DX180 Ref. 91181AW

- Single speed centrifugal unit
- Operated by remote switch

Premier DX180T Ref. 91182AW

- Single speed centrifugal unit with timer
- Built-in fixed 20mins run On period after the light has been switched Off

Premier DX180H Ref. 91183AW

- Single speed centrifugal unit with humidistat
- On/Off humidistat adjustable 50-90% RH

Premier DX200 Ref. 91013AW

- High performance centrifugal unit
- Choice of 2 set speeds

Premier DX200T Ref. 91014AW

- High performance centrifugal unit with timer
- Room size selector matches extract performance for improved efficiency

- 'QuickVisit' delay feature prevents fan from running should light be switched On/Off again within 2mins
- Mechanical trickle ventilation facility
- Built-in run-on period after light switched Off. User adjustable from 30s-20mins

Premier CF20 Ref. 91015AW

- High performance condensation control centrifugal unit
- Step-speed, user adjustable humidistat
- Room size selector matches extract performance for improved efficiency
- Tricklevent and pull cord manual override
- Includes external wall grille

Premier CF20T Ref. 91016AW

- All the features of CF20 plus:
- Auto run-on after light switched Off
- 'QuickVisit' delay feature prevents fan from running should light be switched On/Off again within 2 mins

Controllers

Manual Override Switch MOS Ref. 90199AW

Provides switching between manual and automatic operation. For use in conjunction with remote humidistat

Remote Humidistat XRH Ref. 21856AW

Stand alone humidistat switches fan On/Off when RH reaches pre-set levels. Complete with pullcord override switch

Remote Time Delay Unit DT20B Ref. 21850AW

User adjustable run-on timer (2-20mins)

Passive Infrared Sensor XPIRA Ref. 21871AA

Activates fan via body movement. Ideal for infrequently used public spaces. Built in timer to prevent nuisance tripping

Typical Specifications on page 126.
Wiring Diagrams on page 142.

Performance

DX180 Range

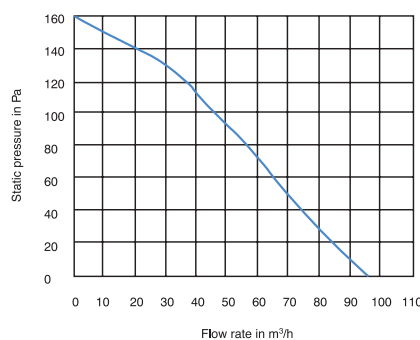

DX200 Range

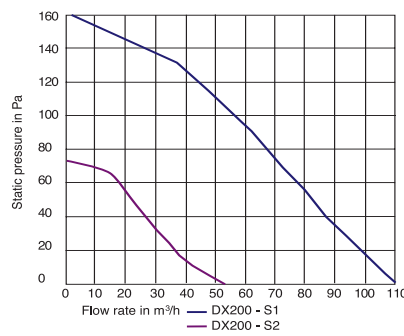

DX200T/CF20

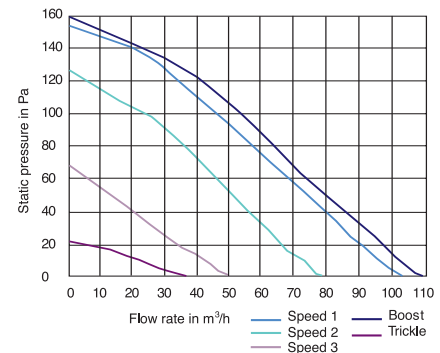

Dimensions

Premier DX180

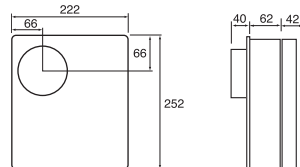

Premier DX200

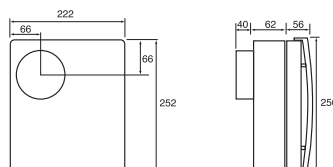

Premier CF20

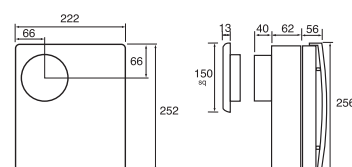

Installation and Accessories

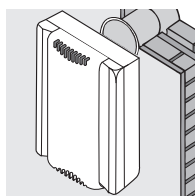

Wall Mounting

Hole diameter: 117mm
Ducting size: 100mm

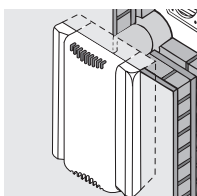

Flush Wall Mounting

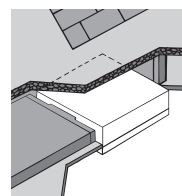

Ceiling Mounting with flat ducting

Hole diameter: 117mm (203 x 233mm flush mounted)
Ducting size: 100mm

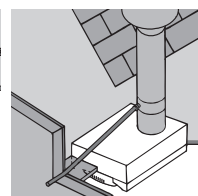

Flush Ceiling Mounted

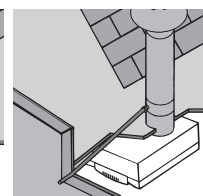

Surface Ceiling Mounted

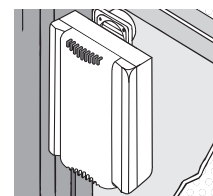

Window Mounting

Hole diameter: 120mm

Installation Accessories

Wall vent kit VK10
Termination ducting kit WT
Wall tube WD100
Easy fit kit EFT

Ref. 89120AW
Ref. 89538AA
Ref. 89543AA
Ref. 90427AA

Installation Accessories

Flat ducting XFP
Flexible ducting FD100
Condensation trap XCT100
Vent cowl VC10
Flat duct adaptor FDA
Ceiling mounting adaptor XCMK

see **Profile 29**
Ref. 89910AA
Ref. 89749AA
Ref. 89531AA
Ref. 90547AA
Ref. 90066AA

Installation Accessories

Glass mounting kit GMK
Ref. 90546AA

Xpelair Premier LoVolt LVDX200 & LVCF20

Safety Extra Low Voltage ventilation



Key features

Type:	LVDX centrifugal extract & LVCF condensation control fans
Application:	Domestic bathrooms, shower rooms, toilets and utility rooms
Control options:	Pull cord, timer & humidistat
Legislation:	Conforms to Building Regulations
Hole size:	117mm (wall) 120mm (window)



Select the right product for your application

	LVDX200	LVDX200T	LVCF20	LVCF20T	
Reference number	91453AW	91040AW	91041AW	91042AW	
Remote switch (not supplied)	■	■		■	
Integral pullcord			■	■	
Integral adjustable run-on timer (30s to 20mins)		■		■	
Humidity sensor (50-90% RH)			■	■	
Quick visit (2 minutes)		■		■	
Speeds	2	2	5	5	
Trickle ventilation facility			■	■	
Extract performance (FID, m ³ /h)	boost		108	108	
	speed 3		102	102	
	speed 2	108	108	79	79
	speed 1	45	45	50	50
	trickle			36	36
Extract performance (FID, l/s)	boost		30	30	
	speed 3		28	28	
	speed 2	30	30	22	22
	speed 1	12.5	12.5	14	14
	trickle			10	10
	boost		50	50	
	speed 3		48	48	
	speed 2	50	50	42	42
	speed 1	30	30	32	32
	trickle			26	26
Electrical power rating (W)	42	42	42	42	
Weight (kg)	2.15	2.15	2.15	2.15	
IP rating	IPX5	IPX5	IPX5	IPX5	
Guarantee (years, UK)	3	3	3	3	

The Range

Splash about with complete peace of mind. The Safety Extra Low Voltage (SELV) versions of the Premier DX200 and CF20 pressure developing centrifugal fans are ideal for use in shower rooms, bathrooms with showers and other zone 1 and zone 2 wet areas. Whilst they are designed specifically for domestic applications, they are also suitable for commercial applications where walls are regularly hosed down. The SELV system consists of a 12V fan unit which can be safely installed in the spray area of a bath or shower, with the transformer located outside the spray area.

Premier models **LVDX200 & LVCF20** conform to Building Regulations covering mechanical ventilation for toilets, bathrooms and utility rooms. Importantly they exceed the IP requirements for zone 1 and zone 2 as defined by IEE Wiring Regulations (16th Edition) BS 7671:2001, and are rated IPX5. The motor is totally enclosed and fitted with self aligning

bearings and thermal overload protection. The motor insulation is class B making them suitable for ambient temperatures up to 40°C.

Premier SELV fans have the same clean and sleek styling as the rest of the Premier range, with a white gloss body and fascia. They are designed for easy installation in walls, ceilings, windows or ducted installation at any angle, and **LVCF20** models come complete with a brown 100mm grille for wall or soffit fixing. All models come complete with a universal mounting kit and an automatic backdraught shutter.

The two part casing permits recessed or surface mounting, and can be fitted into ceilings and studwork wall recesses as little as 50 mm deep using the top entry knockout provided and an FDA adaptor and Profile 29 flat duct. Alternatively 100mm diameter circular duct can be used. A clip-off front and removable fan blade make for easy cleaning.

Models

Premier LVDX200

Ref. 91453AW

- High performance centrifugal unit
- Stylish 2 piece fascia with neon indicator
- Choice of 2 set speeds
- Operated by remote switch eg. lighting circuit

Premier LVDX200T

Ref. 91040AW

- High performance centrifugal unit with timer
- Stylish 2 piece fascia
- Operated by remote switch eg. lighting circuit
- 'QuickVisit' delay feature prevents fan from running should light be switched On/Off again within 2mins
- Built-in run-on period after light switched Off. User adjustable from 30s-20mins
- Neon indicator

Premier LVCF20

Ref. 91041AW

- High performance condensation control centrifugal unit
- Integral condensation controller
- Stylish 2 piece fascia
- User adjustable humidistat (50-90% RH)
- Room size selector matches extract performance for improved efficiency
- Trickle ventilation facility
- Automatic or pull cord manual override
- Includes external wall grille
- Neon indicator

Premier LVCF20T

Ref. 91042AW

- High performance condensation control centrifugal unit with timer (30s-20mins)
- Integral condensation controller
- Stylish 2 piece fascia
- User adjustable humidistat (50-90% RH)
- Room size selector matches extract performance for improved efficiency
- Operated by remote switch eg. lighting circuit
- Trickle ventilation facility
- Automatic or pull cord manual override
- Neon indicator
- Includes external wall grille

Typical Specifications on page 126.
Wiring Diagrams on page 142.

Performance

LVDX200 Range

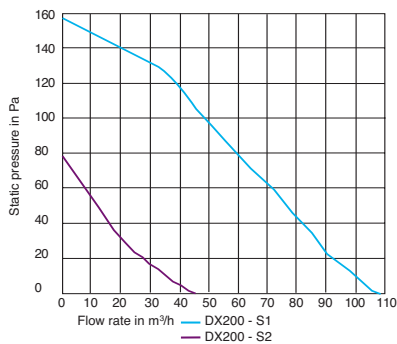

LVCF20 Range

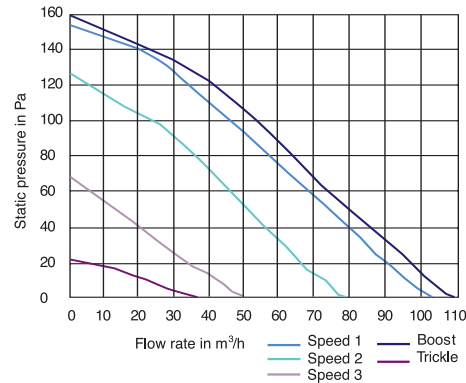

Dimensions

LVDX200 Range

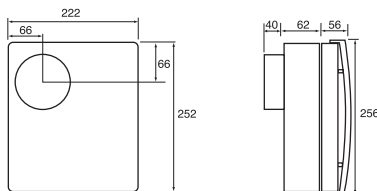

LVCF20 Range

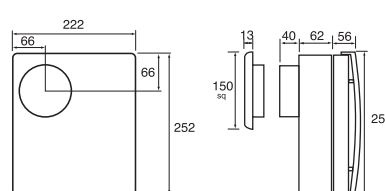

LV transformer

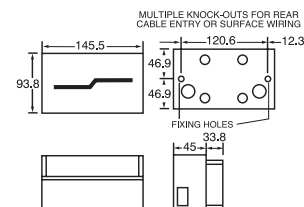

Installation and Accessories

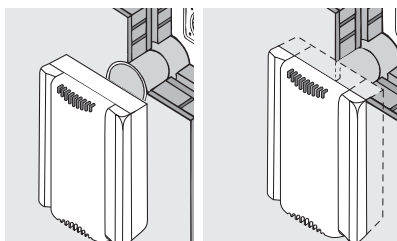

Wall Mounting

Flush Wall Mounting

Hole diameter: 117mm
Ducting size: 100mm

Installation Accessories

Wall tube WD100
Wall vent kit VK10

Ref. 89543AA
Ref. 89120AW

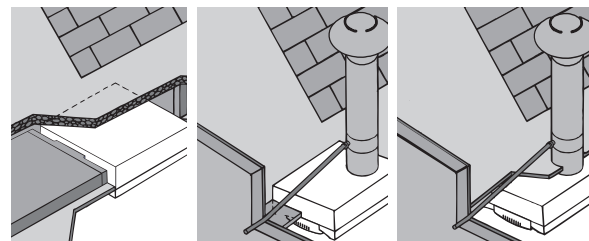

Ceiling Mounting with flat ducting

Flush Ceiling Mounted

Surface Ceiling Mounted

Hole diameter: 117mm (203 x 233mm flush mounted)
Ducting size: 100mm

Installation Accessories

Flat ducting XFP
Flexible ducting FD100
Condensation trap XCT100
Vent cowl VC10
Flat duct adaptor FDA
Ceiling mounting adaptor XCMK

see **Profile 29**
Ref. 89910AA
Ref. 89749AA
Ref. 89531AW
Ref. 90547AA
Ref. 90066AA

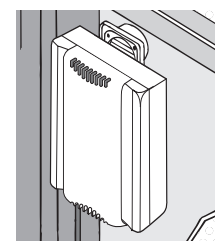

Window Mounting

Hole diameter: 120mm

Installation Accessories

Glass mounting kit GMK
Ref. 90546AA

Xpelair DX100 & XX100

100mm axial extract fans



Key features

Type: **Axial extract fans**

Application: **Domestic bathrooms, shower rooms and toilets**

Control options: **Pull cord, timer, humidistat and PIR**

Legislation: **Conforms to Building Regulations**

Hole dia: **115mm (wall)
125mm (window)**



The Range

A comprehensive range of stylish, compact and easy to install single speed fans. Suitable for a wide range of domestic applications including bathrooms, shower rooms and toilets, including zones 1 & 2. Also suitable for commercial applications such as hotel bathrooms, office toilets and other small rooms.

DX100 models have a softly curved flowline grille design which will blend into wall or ceiling décor, whilst the shallow depth of the outlet spigot ensures compact window installation. All models come complete with a universal mounting kit suitable for wall, ceiling and window mounting (in single glazing up to 6mm) applications. The DX range includes

an air operated backdraught shutter, outer grille and ducting. Control options include integral pull cord and timer; humidistat and PIR options offer automatic control.

XX100 models are supplied without a kit and are ideal for replacement applications or where a suitable outlet already exists.

All models are IPX5 rated (except **DX100PIR**) and BEAB approved, demonstrating accredited levels of safety. They are all suitable for 220-240V 50Hz mains operation, have lubricated for life motors, Class B insulation for operation in ambient temperatures up to 40°C and are fitted with a thermal cut out.

Select the right product for your application

	DX100	DX100PC	DX100T	DX100H	DX100HP	DX100PIR	XX100	XX100P	XX100T
Reference number	90839AW	90840AW	90841AW	90842AW	90843AW	90844AW	90872AW	90873AW	90874AW
Remote switch (supplied separately)	■		■				■		■
Integral pullcord		■			■			■	
Integral timer (adjustable from 2-20 mins)			■	■	■	■			■
Humidity sensor (50-90% RH)				■	■				
Passive infrared sensor						■			
Maximum air flow (m ³ /h)	76	76	76	76	76	76	76	76	76
Maximum air flow (l/s)	21	21	21	21	21	21	21	21	21
Sound pressure level dB(A)@3m	35	35	35	35	35	35	41	41	41
Electrical power rating (W)	12	12	12	12	12	12	12	12	12
Weight (kg)	1.2	1.2	1.2	1.2	1.2	1.2	0.8	0.8	0.8
IP rating	IPX5	IPX5	IPX5	IPX5	IPX5	IPX4	IPX5	IPX5	IPX5
Universal mounting kit	■	■	■	■	■	■			
Guarantee (years, UK)	3	3	3	3	3	3	3	3	3

Models

DX100

Ref. 90839AW

- Single speed axial unit
- Operated by a remote switch. In a bathroom normally a separate pullcord or the lighting circuit
- Includes universal mounting kit
- Colour: White

DX100PC

Ref. 90840AW

- Single speed axial unit with pullcord
- Operated by integral pullcord
- Includes universal mounting kit
- Colour: White

DX100T

Ref. 90841AW

- Single speed axial unit with timer
- Timer triggered by a remote switch - usually the lighting circuit
- Adjustable timer (2-20mins)
- Includes universal mounting kit
- Colour: White

DX100H

Ref. 90842AW

- Single speed axial unit with humidistat
- Automatic On/Off operation by integral humidity sensor, adjustable from 50-90% RH
- Timer function adjustable (2-20mins)
- Includes universal mounting kit
- Colour: White

DX100HP

Ref. 90843AW

- Single speed axial unit with humidistat and pullcord
- Timer function adjustable (2-20mins)

- Automatic On/Off operation by integral humidity sensor, adjustable from 50-90% RH
- Pullcord On feature overrides the auto-humidity sensor function
- Includes universal mounting kit
- Colour: White

DX100PIR

Ref. 90844AW

- Single speed axial unit with PIR detector
- Automatic On/Off operation
- Integral passive infrared sensor
- Includes universal mounting kit
- Colour: White

XX100

Ref. 90872AW

- Single speed axial unit
- Operated by remote switch
- Colour: White

XX100P

Ref. 90873AW

- Single speed axial unit with pullcord
- Operated by integral On/Off pullcord
- Colour: White

XX100T

Ref. 90874AW

- Single speed axial unit with timer
- Normally triggered by a remote switch, for example the lighting circuit
- Colour: White

Typical Specifications on page 126.
Wiring Diagrams on page 142.

Controllers

Remote Humidistat XRH

Ref. 21856AW

- Stand alone humidistat switches fan On/Off when RH reaches pre-set levels. Complete with pullcord override switch

Time Delay Unit DT20B

Ref. 21850AW

- User adjustable run on timer (2-20mins)

Passive Infrared Sensor XPIRA

Ref. 21871AA

- Activates fan via body movement. Ideal for infrequently used public spaces. Built in timer to prevent nuisance tripping

Performance

DX100 / XX100 Range

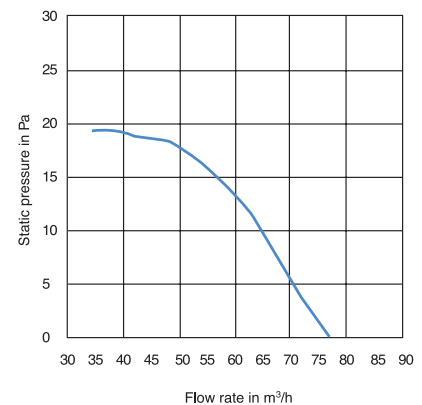

Dimensions

DX100 Range

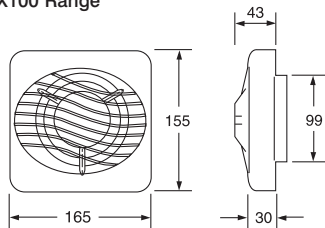

Back draught shutter

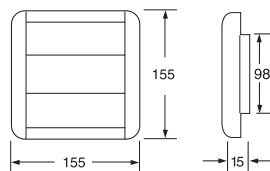

XX100

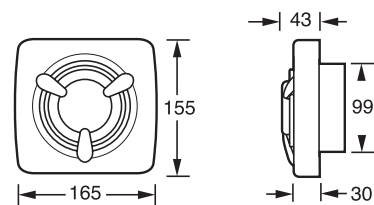

Installation and Accessories

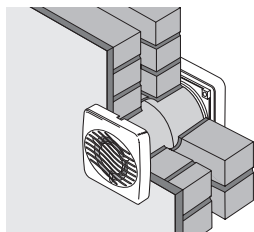

Wall Mounting

Hole diameter: 115mm
Ducting size: 100mm

Installation Accessories

Easy fit kit EFT
Ref. 90427AA
Vent cowl VC10
Ref. 89531AA
Air brick adaptor XAA
Ref. 89777AA

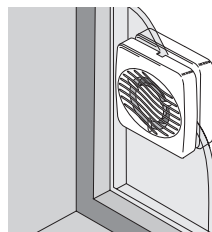

Window Mounting

Hole diameter: 125mm

Installation Accessories

Double glazing kit DXDG
Ref. 07439AA

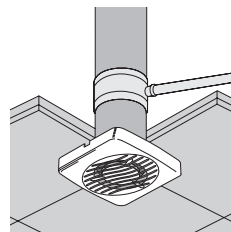

Ceiling Mounting

Hole diameter: 115mm
Ducting size: 100mm

Installation Accessories

Condensation trap XCT100
Ref. 89749AA
Vent cowl VC10
Ref. 89531AA

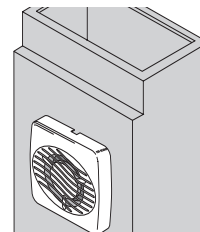

Ventilation Shaft Mounting

Hole diameter: 110mm

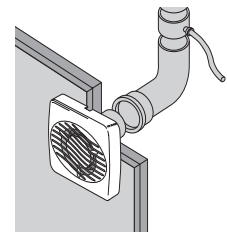

Ducting Application

Hole diameter: 110mm
Ducting size: 100mm

Installation Accessories

Condensation trap XCT100
Ref. 89749AA

Xpelair LoVolt LV100

Safety Extra Low Voltage 100mm axial extract fans



Key features

Type:	Safety Extra Low Voltage axial extract fan
Application:	Domestic bathrooms, shower rooms and toilets
Control options:	Pull cord, timer, humidistat & PIR
Legislation:	Conforms to Building Regulations
Hole dia:	115mm (wall) 125mm (window)



The Range

Water, water everywhere and none in the right place!

Whether you are showering, or leaving the kids splashing in the bath, water gets everywhere. Xpelair **LV100** fans are 12V Safety Extra Low Voltage (SELV) units offering complete peace of mind. These fans are specifically designed to be installed directly in or over the splash area zone 1 in complete safety, with the SELV transformer sited out of reach of any person using the bath or shower.

The front fascia with its softly curved flowline grille design will blend into wall or ceiling décor, whilst the shallow depth of the outlet spigot ensures compact window installation. All models come complete with a universal mounting kit suitable for wall, ceiling and window mounting (in single glazing up to 6mm) applications.

The kit includes an air operated backdraught shutter and all models are supplied with a 12V SELV transformer. Control options include integral pull cord and timer. Humidistat and PIR options offer automatic control.

The **LV100** range conform to Building Regulations mechanical ventilation for toilets and bathrooms. The Xpelair SELV system exceeds the IP requirements for zone1 and zone 2 as defined by IEE wiring Regulations (16th Edition) BS 7671:2001. All models are IPX5 rated and BEAB approved, demonstrating accredited levels of safety. They are all suitable for 220-240V 50Hz mains operation, have lubricated for life motors, Class B insulation for operation in ambient temperatures up to 40°C and are fitted with a thermal cut out.

Select the right product for your application

	LV100	LV100PC	LV100T	LV100H	LV100HP	LV100PIR
Reference number	90845AW	90846AW	90847AW	90848AW	90849AW	90867AW
Remote switch (supplied separately)	■		■			
Integral pullcord		■			■	
Integral timer (adjustable from 2-20 mins)			■	■	■	■
Integral humidity sensor (50-90% RH)				■	■	
Passive infrared sensor						■
Extract performance (FIDm m ³ /h)	85	85	85	85	85	85
Extract performance (FID, l/s)	24	24	24	24	24	24
Sound pressure level (dB(A)@3m)	37	37	37	37	37	37
Electrical power rating (W)	13	13	13	13	13	13
Weight (kg)	2.2	2.2	2.2	2.2	2.2	2.2
IP rating	IPX5	IPX5	IPX5	IPX5	IPX5	IPX5
Guarantee (years, UK)	3	3	3	3	3	3

Models

LV100

Ref. 90845AW

- Single speed 12V SELV axial unit and remote SELV transformer
- Operated by remote switch (in a bathroom normally a separate pullcord or lighting circuit)
- Includes universal mounting kit
- Colour: White

LV100PC

Ref. 90846AW

- Single speed 12V SELV axial unit with pullcord and remote SELV transformer
- Operated by integral pullcord
- Includes universal mounting kit
- Colour: White

LV100T

Ref. 90847AW

- Single speed 12V SELV axial unit with timer and remote SELV transformer
- Timer triggered by a remote switch, for example the lighting circuit. Timer variable from 2-20mins
- Includes universal mounting kit
- Colour: White

LV100H

Ref. 90848AW

- Single speed 12V SELV axial unit with humidistat and remote SELV transformer
- Automatic On/Off operation by integral humidity sensor. Adjustable from 50-90% RH

- Adjustable timer function (2-20mins)
- Includes universal mounting kit
- Colour: White

LV100HP

Ref. 90849AW

- Single speed 12V SELV axial unit with humidistat, pullcord and remote SELV transformer
- Automatic On/Off operation by integral humidity sensor. Adjustable from 50-90% RH
- Adjustable timer function (2-20mins)
- Pullcord On feature overrides the auto-humidity sensor function
- Includes universal mounting kit
- Colour: White

LV100PIR

Ref. 90867AW

- Single speed 12V SELV axial unit with PIR detector and remote SELV transformer
- Automatic On/Off operation
- Integral passive infrared sensor
- Adjustable timer function (2-20mins)
- Includes universal mounting kit
- Colour: White

Typical Specifications on page 127.
Wiring Diagrams on page 142.

Controllers

LoVolt Remote Humidistat LVH

Ref. 21863AW

- Stand alone humidistat switches fan On/Off when the relative humidity reaches pre-set levels. This level is user adjustable to suit each application

Performance

LV100 Range

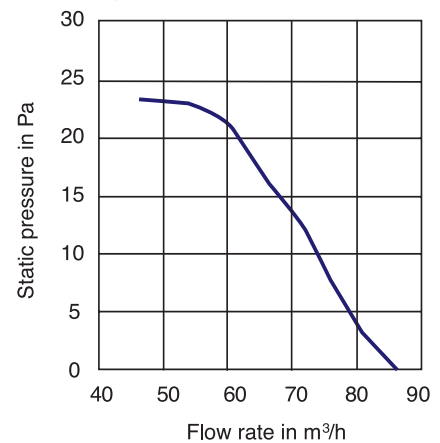

Dimensions

LV100 Range

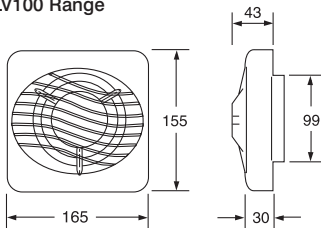

Back Draught Shutter

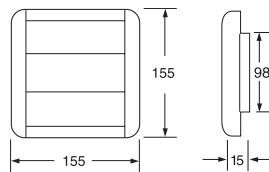

LV100 Transformer

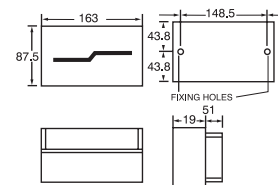

Installation and Accessories

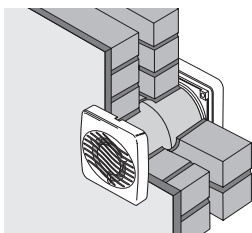

Wall Mounting

Hole diameter: 115mm
Ducting size: 100mm

Installation Accessories

Easy fit kit EFT
Ref. 90427AA
Vent cowl VC10
Ref. 98409AA
Air brick adaptor XAA
Ref. 89777AA

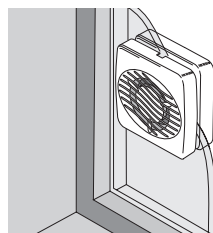

Window Mounting

Hole diameter: 125mm

Installation Accessories

Double glazing kit DXDG
Ref. 07439AA

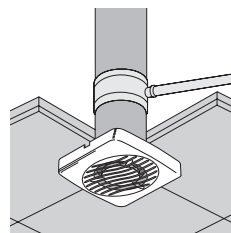

Ceiling Mounting

Hole diameter: 115mm
Ducting size: 100mm

Installation Accessories

Condensation trap XCT100
Ref. 89749AA
Vent cowl VC10
Ref. 89531AA

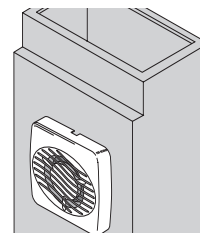

Ventilation Shaft Mounting

Hole diameter: 110mm

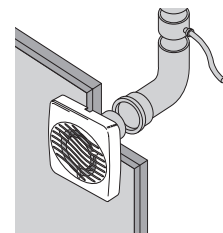

Ducting Application

Hole diameter: 110mm
Ducting size: 100mm

Installation Accessories

Condensation trap XCT100
Ref. 89749AA

Xpelair Slimline SL100 & SL150

Wafer thin axial fans



Key features

Type: **Axial extract fan with wafer thin grille**

Application: **Domestic bathrooms, shower rooms and toilets**

Control options: **Pull cord, timer & humidistat**

Legislation: **Conforms to Building Regulations**

Hole size: **100mm (SL100)
150mm (SL150)**



The Range

Meet the new generation of Xpelair **Slimline SL100** and **SL150** fans, with wall hugging wafer-thin grilles designed for modern living. They are white in colour and are ideal for domestic bathrooms, shower rooms, toilets and other small rooms. With an internal projection of only 15mm, the 100mm Xpelair **Slimline** unit is one of the lowest profile bathroom fans available. For bigger bathrooms **Slimline** is also available in a 150mm size offering performance and style.

For rooms with no opening windows **Slimline SL100** is available with a built-in overrun timer. Humidistat models are available for shower rooms and heavily used bathroom applications. Ordering is straight-forward: simply select the size

and control option required, then add the appropriate window or wall kit.

But the **Slimline** range doesn't just have a pretty face, installation is simple too. All **Slimline** models have two adjustable QuickClamp fixings which make traditional wall plug and screw fixings a thing of the past.

The IPX4 rated units fully meet the requirements of the Building Regulations for bathrooms, toilets and kitchens and the IP requirements for zone 1 and zone 2 as defined by the IEE Wiring Regulations (16th Edition) BS7671:2001. All models are suitable for a supply voltage of 220-240V 50Hz and ambient temperatures up to 40°C.

Select the right product for your application

	SL100	SL100P	SL100T	SL100HT	SL150	SL150P	SL150HT
Reference number	91225AW	91226AW	91227AW	91228AW	91229AW	91230AW	91231AW
Remote switch (supplied separately)	■		■		■		
Integral pullcord		■				■	
Integral timer (adjustable up to 15 mins)			■	■			■
Integral humidity sensor (45-99% RH)				■			■
Extract performance (FID, m ³ /h)	67	67	67	67	180	180	180
Extract performance (FID, l/s)	18.5	18.5	18.5	18.5	50	50	50
Sound pressure level (dB(A)@3m)	39	39	39	39	43	43	43
Electrical power rating (W)	15	15	15	15	25	25	25
Weight (kg)	0.6	0.6	0.6	0.6	0.9	0.9	0.9
IP rating	IPX4	IPX4	IPX4	IPX4	IPX4	IPX4	IPX4
Guarantee (years, UK)	2	2	2	2	2	2	2

Models

SL100

Ref. 91225AW

- Single speed axial fan
- Operated by remote switch (in a bathroom normally a separate pullcord or lighting circuit)
- Colour: White

SL100P

Ref. 91226AW

- Single speed axial fan with pullcord
- Operated by integral On/Off pullcord switch
- Colour: White

SL100T

Ref. 91227AW

- Single speed axial fan with timer
- Timer triggered by remote switch-usually the lighting circuit
- Timer variable from 3-15mins
- Colour: White

SL100HT

Ref. 91228AW

- Single speed axial fan with humidistat and overrun timer
- Built in adjustable humidistat
- Integrated overrun timer eliminates nuisance tripping
- Timer variable from 45s-15mins
- Colour: White

SL150

Ref. 91229AW

- Single speed axial fan
- Operated by a remote switch, usually a lighting circuit
- Colour: White

SL150P

Ref. 91230AW

- Single speed axial fan with pullcord
- Operated by integral On/Off pullcord switch
- Colour: White

SL150HT

Ref. 91231AW

- Single speed axial fan with humidistat and overrun timer
- Built in adjustable humidistat
- Integrated overrun timer eliminates nuisance tripping
- Timer variable from 45s-15mins
- Colour: White

Performance

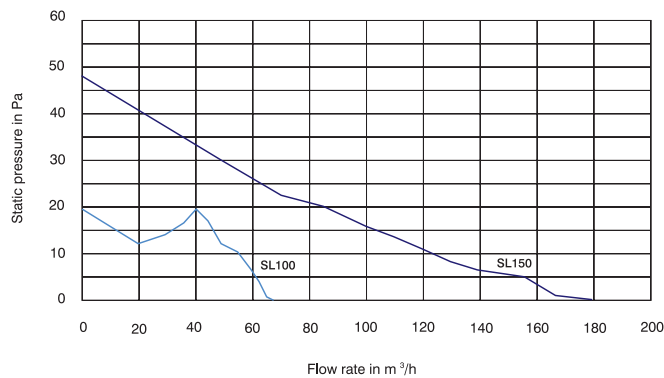

Controllers

Passive Infrared Sensor XPIRA

Ref. 21871AA

- Activates fan via body movement
- Ideal for infrequently used public spaces
- Built in timer to prevent nuisance tripping

Remote Time Controller DT20B

Ref. 21850AW

- User adjustable run-on timer (2-20mins)

Typical Specifications on page 127.
Wiring Diagrams on page 142.

Dimensions

SL100 Range

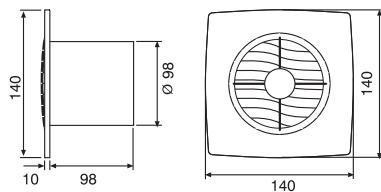

SL150 Range

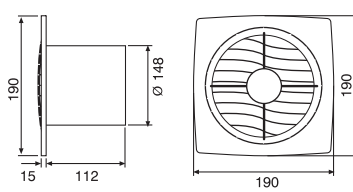

Installation and Accessories

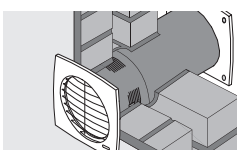

Wall Mounting

Hole diameter: 100mm (SL100)
150mm (SL150)

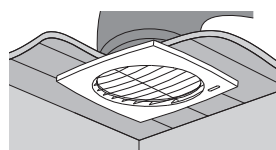

Ceiling Mounting

Hole diameter: 100mm (SL100)
150mm (SL150)

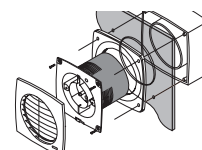

Window Mounting

Hole diameter: 100mm (SL100)
150mm (SL150)

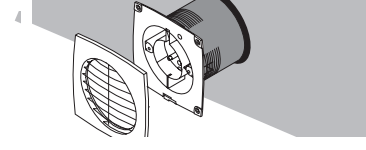

Ducted Applications

Hole diameter: 100mm (SL100)
150mm (SL150)
Duct diameter: 100mm (SL100)
150mm (SL150)

Installation Accessories

SL100 wall kit SLWK
Ref. 91232AW
SL150 wall kit SLWK
Ref. 91233AW

Installation Accessories

Flexible ducting FD100
Ref. 89910AA
Flexible ducting FD150
Ref. 89671AA
Condensation trap XCT100
Ref. 89749AA

Installation Accessories

SL100 window kit
Ref. 91234AW
SL150 window kit
Ref. 91235AW

Installation Accessories

Flexible ducting FD100
Ref. 89910AA
Flexible ducting FD150
Ref. 89671AA

Xpelair CentrX

Centrifugal panel fans



Key features

Type:	Single speed centrifugal panel fans
Application:	Domestic bathrooms, shower rooms, toilets and utility rooms
Control options:	Pull cord, timer & humidistat
Legislation:	Conforms to Building Regulations
Hole size:	150mm (CT100) 100mm (CT100+)

The Range

CentrX is a range of two sizes of pressure developing centrifugal panel fans for ducted or through the wall applications. They are the ideal solution for ducted applications where extra pressure development is required, including toilets, bathrooms, shower rooms, utility rooms and kitchens. They are recommended in place of an axial fan in exposed coastal situations or exposed high rise applications. They are also suitable for commercial applications for the ventilation of small internal rooms.

The slim stylish grille is easily recognisable as Xpelair, with a bellmouth entry and finger guard through which air is drawn directly into the eye of the high performance centrifugal fan. The spigot outlet on both sizes of unit is only 100mm reducing space requirements for flexible ducting or Profile 60 rigid flat ductwork.

For simplified installation models are available with a built-in overrun timer and humidistat. They can be installed at any angle. All have an 'On' indicator light and a maintenance free motor with sealed for life bearings and safety thermal overload protection.



Select the right product for your application

	CT100	CT100T	CT100HT	CT100+	CT100+P	CT100+HT
Reference number	91236AW	91237AW	91238AW	91239AW	91240AW	91241AW
Remote switch (supplied separately)	■			■		
Integral pullcord					■	
Integral timer (adjustable)		■	■			■
Integral humidity sensor			■			■
Extract performance (FID, m ³ /h)	62	62	62	169	169	169
Extract performance (FID, l/s)	17	17	17	47	47	47
Sound pressure level (dB(A)@3m)	49	49	49	52	52	52
Electrical power rating (W)	25	25	25	45	45	45
Weight (kg)	0.98	0.98	0.98	1.64	1.64	1.64
IP rating	IPX4	IPX4	IPX4	IPX4	IPX4	IPX4
Guarantee (years, UK)	2	2	2	2	2	2

Models

CT100

Ref. 91236AW

- Centrifugal panel fan
- Can be installed at any angle
- Operated by remote switch. In a bathroom usually a pullcord or wired to the lighting circuit
- On indicator light
- Slim fascia with bellmouth and fingerguard
- 100mm duct spigot
- Maintenance free motor with sealed for life bearings and safety thermal overload protection
- Colour: White

CT100T

Ref. 91237AW

- Centrifugal panel fan with timer
- Connected to the room wiring circuit.
- Provides a preset timed overrun (3-15mins) after the light has been switched off
- Can be installed at any angle.
- On indicator light.
- Slim fascia with bellmouth and fingerguard
- 100mm duct spigot
- Maintenance free motor with sealed for life bearings and safety thermal overload protection
- Colour: White

CT100HT

Ref. 91238AW

- Centrifugal panel fan with humidistat and timer
- Auto humidity control switches the fan on with a rise in humidity above the preset level.
- Overrun timer (adjustable from 45s-15min) ensures the absence of nuisance tripping
- Can be installed at any angle
- On indicator light
- Slim fascia with bellmouth and fingerguard
- 100mm duct spigot
- Maintenance free motor with sealed for life bearings and safety thermal overload protection
- Colour: White

CT100+

Ref. 91239AW

- High output centrifugal panel fan
- For larger bathrooms, utility rooms and kitchens
- Can be installed at any angle
- Operated by proprietary remote switch
- With bellmouth and fingerguard
- 100mm duct spigot
- Maintenance free motor with sealed for life bearings and safety thermal overload protection
- Colour: White

CT100+P

Ref. 91240AW

- Integral pullcord operation
- With bellmouth and fingerguard
- 100mm duct spigot
- Maintenance free motor with sealed for life bearings and safety thermal overload protection
- Colour: White

CT100+HT

Ref. 91241AW

- With humidistat
- Auto humidity control switches the fan on with a rise in humidity above the preset level.
- Overrun timer (adjustable from 45s-15min) prevents nuisance tripping
- Can be installed at any angle
- With bellmouth and fingerguard
- 100mm duct spigot
- Maintenance free motor with sealed for life bearings and safety thermal overload protection
- Colour: White

Typical Specifications on page 127.
Wiring Diagrams on page 143.

Performance

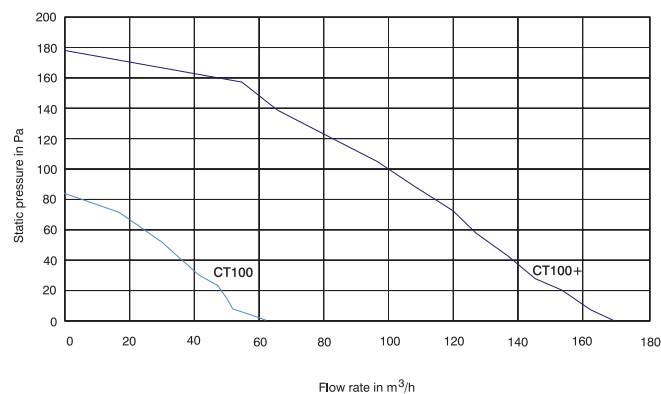

Controllers

Remote Humidistat XRH

Ref. 21856AW

- Stand alone humidistat switches fan On/Off when RH reaches pre-set levels. Complete with pullcord override switch

Remote Time Controller DT20B

Ref. 21850AW

- User adjustable run on timer (2-20mins)

Passive Infrared Sensor XPIRA

Ref. 21871AA

- Activates fan via body movement. Ideal for infrequently used public spaces. Built in timer to prevent nuisance tripping

Dimensions

CentrX 100 Range

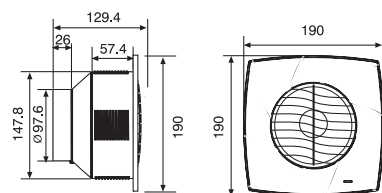

CentrX 100+ Range

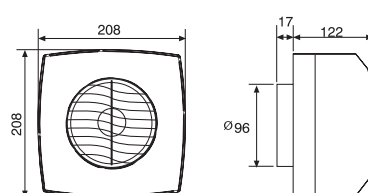

Installation and Accessories

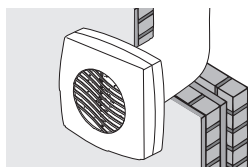

Wall Mounting

Hole diameter: CT100 150mm
CT100+ 100mm
Ducting size: 100mm

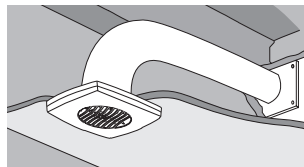

Ceiling mounting with ducting

Hole diameter: CT100 150mm
CT100+ 100mm
Ducting size: 100mm

Installation Accessories

Wall Mounting

Wall tube WD100

Ref. 89543AA

Telescopic wall vent kit VK10

Ref. 89120AW

Ceiling Mounting

Flexible ducting FD100

Ref. 89663AA

Ceiling mounting adaptor

Ref. 90066AA

Condensation trap XCT100

Ref. 89749AA

Weather cowl VC10

Ref. 89531AA

Xpelair XIL Inline shower fan systems

Axial extract fans for shower cubicle applications



Key features

Type:	Inline single speed axial extract fans and systems
Application:	Domestic bathrooms and shower rooms
Control options:	Standard or timer
Legislation:	Conforms to Building Regulations
Hole size:	115mm (XIL100/XXS100) 140mm (XIL125) 165mm (XIL150)



The Range

Step out of the shower cubicle. Is the mirror 'steamed over'?...

There is another way.

Remove the cause of condensation at source with an Xpelair inline shower fan system.

With a neat grille installed directly over the shower, humid or moist air will be ducted away by a fan above the ceiling and onwards to a grille installed outside, typically in the soffit.

Will I be standing in a draught? No, air will not be pulled into a normal cubicle, only flow over it.

XXS100 fans are available on their own.

XIL fans are available in sizes of 100, 125 & 150mm and are only available as fan systems. The systems contain all the components necessary for a normal installation, comprising:

- inline fan
- 3m of flexible duct
- Four worm drive clips
- inline backdraught shutter (XIL100)
- Internal ceiling grille with sleek styling in white
- Outside soffit/wall grille

Xpelair inline shower fan systems exceed the IP requirements for zone 1 and zone 2 as defined by IEE wiring Regulations (16th Edition) BS 7671:2001. All electronics circuits and wiring terminals are fully protected. Motors are Class B lubricated for life, fitted with safety thermal overload protection and suitable for ambient temperatures up to 40°C.

Xpelair **XIL** systems conform to Building Regulations mechanical ventilation for toilets shower rooms and bathrooms.

Select the right product for your application

	XIL100	XIL100T	XIL125	XIL125T	XIL150	XIL150T	XXS100	XXS100T
Reference number	90329AW	90330AW	91242AW	91243AW	91244AW	91245AW	90331AW	90332AW
Fan only							■	■
Fan system (installation pack)	■	■	■	■	■	■		
Remote switch (not included)	■	■	■	■	■	■	■	■
Integral timer (adjustable)		■		■		■		■
Extract performance (m ³ /h*)	46	46	63	63	133	133	85	85
Extract performance (l/s*)	13	13	18	18	37	37	24	24
Sound pressure level (dBA)@3m)	30	30	43	43	45	45	33	33
Electrical power rating (W)	12	12	20	20	25	25	12	12
Weight (kg)	0.9	0.9	1.83	1.83	2.1	2.1	0.8	0.8
Duct diameter (mm)	100	100	125	125	150	150	100	100
Hole size (mm)	115	115	140	140	165	165	115	115
IP rating	IPX2	IPX2	IPX2	IPX2	IPX2	IPX2	IPX2	IPX2
Guarantee (years, UK)	3	3	2	2	2	2	2	2

*XXS fan only performance measured FID, XIL fan systems measured in typical installation (comprising 90° bend on the inlet & outlet plus 3m of duct).

Models

XIL100

Ref. 90329AW

- Single speed Inline showerfan system.
- Operated by remote switch (in a bathroom whether by remote pullcord switch or wired to the lighting circuit)
- Can also be wired to a water flow switch fitted in the pipework to the shower control to switch On/Off when the shower is in use

XIL100T

Ref. 90330AW

- Single speed inline showerfan system
- Built-in overrun timer (adjustable at installation from 2-20mins)
- Operated by remote switch (in a bathroom wired to the lighting circuit)
- Can also be wired to a water flow switch, fitted in the pipework to the shower control, to switch On/Off when the shower is in use

XIL125

Ref. 91242AW

- Single speed inline showerfan system
- Operated by remote switch (in a bathroom either by a remote pullcord

switch or wired to the lighting circuit)

Can also be wired to a water flow switch fitted in the pipework to the shower control to switch On/Off when the shower is in use

XIL125T

Ref. 91243AW

- Single speed inline showerfan system
- Built-in overrun timer (adjustable at installation from 3-15mins)
- Operated by remote switch (in a bathroom wired to the lighting circuit)
- Can also be wired to a water flow switch, fitted in the pipework to the shower control, to switch On/Off when shower is in use

XIL150

Ref. 91244AW

- Single speed inline showerfan system
 - Operated by remote switch (in a bathroom either by a remote pullcord switch or wired to the lighting circuit)
- Can also be wired to a water flow switch fitted in the pipework to the shower control to switch On/Off when the shower is in use

XIL150T

Ref. 91245AW

- Single speed inline showerfan system
- Built-in overrun timer (adjustable at installation from 3-15mins)
- Operated by remote switch (in a bathroom wired to the lighting circuit)
- Can also be wired to a water flow switch, fitted in the pipework to the shower control, to switch On/Off when shower is in use

XXS100

Ref. 90331AW

- Single speed inline fan
- Operated by remote switch

XXS100T

Ref. 90332AW

- Single speed inline fan
- Integral timer operated by remote switch (adjustable from 2-20mins)

Typical Specifications on page 128.
Wiring Diagrams on page 143.

Performance

XXS100/XIL100

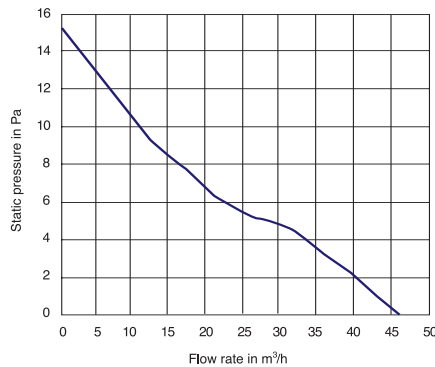

XIL125/150

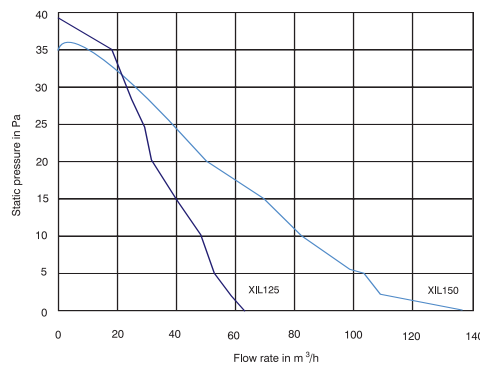

Dimensions

XIL range

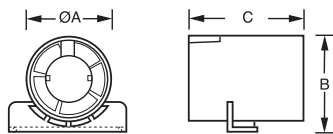

Dimensions (mm)			
Model	ØA	B	C
XIL100/T	100	108	109
XIL125/T	118	118	96
XIL150/T	148	177	108
XXS100/T	100	108	109

Installation and Accessories

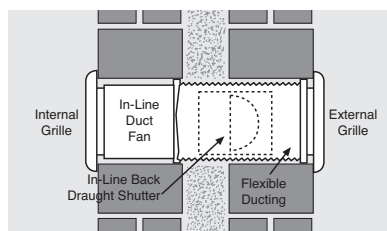

Wall Mounting

Hole diameter: 115/140/165mm*
Ducting size: 100/125/150mm*

*refer to table opposite

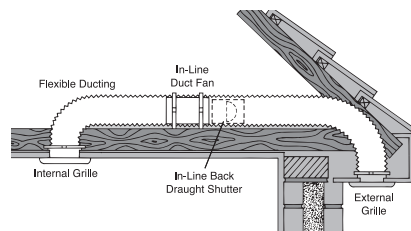

Loft Mounting

Hole diameter: 115/140/165mm*
Ducting size: 100/125/150mm*

*refer to table opposite

Xpelair BriteX LoVolt & BriteX Turbo

Shower fan and light systems



Key features

Type:	Inline single speed axial extract fans and systems
Application:	Domestic toilets, bathrooms & shower rooms
Control options:	Standard or timer
Legislation:	Conforms to Building Regulations



The Range

Brighten up your showering experience.

Shut the door on your shower and you are probably standing in the darkest part of your bathroom. Xpelair **BriteX** range is designed to extract condensation laden air directly from above the shower whilst bathing the cubicle in warm light.

Xpelair **BriteX** kits include everything needed for a standard installation including a stylish ceiling inlet complete with bezel and 12V 50W sealed dichroic lamp, an inline extract fan, 12V Safety Extra Low Voltage (SELV) transformer, flexible ducting, duct ties and a soffit/wall grille. The kits are available in a choice of white or chrome bezel.

BriteX LoVolt is suitable for shorter duct runs (3m duct supplied) in shower cubicles, bathrooms and toilets. For larger shower rooms and longer ducts choose **BriteX Turbo** which comes complete with 6 meters of flexible ducting. For bathrooms without windows versions with an adjustable timer overrun are available, adjustable from 1-20 minutes. The fan is typically connected to the bathroom lighting, and it continues to run after the light has been switched off.

The motor housing is made from ABS and has a detachable mounting foot. All **BriteX** systems can be installed in zone 1 in accordance with IEE Regulations 16th Edition. All versions are IPX4 rated and suitable for use with a supply voltage of 220-240V 50Hz. The fan motor is sealed for life maintenance free and is fitted with safety thermal overload protection.

Select the right product for your application

	BX100W	BX100WT	BX100C	BX100CT	BX100+W	BX100+WT	BX100+C	BX100+CT
Reference number	91184AW	91185AW	91186AW	91187AW	91248AW	91250AW	91249AW	91251AW
Colour	white	white	chrome	chrome	white	white	chrome	chrome
Performance	standard	standard	standard	standard	turbo	turbo	turbo	turbo
Lamp voltage (V)	LoVolt	LoVolt	LoVolt	LoVolt	LoVolt	LoVolt	LoVolt	LoVolt
Remote switch (supplied separately)	■	■	■	■	■	■	■	■
Integral timer (adjustable from 1-20 mins)	■	■	■	■	■	■	■	■
Extract performance (m ³ /h)	56*	56*	56*	56*	74	74	74	74
Duct length (supplied)	3m	3m	3m	3m	6m	6m	6m	6m
Sound pressure level (dB(A)@3m)	36	36	36	36	55	55	55	55
Electrical power rating (W)	15	15	15	15	25	25	25	25
Weight (kg)	0.5	0.5	0.5	0.5	2.1	2.1	2.1	2.1
IP rating	IPX4	IPX4	IPX4	IPX4	IPX4	IPX4	IPX4	IPX4
Guarantee (years, UK)	3	3	3	3	2	2	2	2

*fan only performance for the BX100 range

Models

BriteX LoVolt

BX100W white bezel

Ref. 91184AW

BX100C chrome bezel

Ref. 91186AW

- Suitable for shower cubicles, bathrooms and toilets
- Stylish SELV rated air inlet with 50W sealed dichroic lamp
- SELV transformer
- IPX4 rated double insulated fan
- ABS housing with detachable mounting foot
- Sealed for life maintenance free motor
- Safety thermal overload protection
- 3m of flexible ducting
- Duct ties
- Soffit/wall grille colour brown

BriteX LoVolt T

BX100WT white bezel

Ref. 91185AW

BX100CT chrome bezel

Ref. 91187AW

- Fan fitted with overrun timer adjustable from 1-20mins
- Fan is typically connected to the bathroom lighting. Fan continues to run after the light has been switched off
- Suitable for shower cubicles, bathrooms and toilets

- Stylish SELV rated air inlet with 50W sealed dichroic lamp
- SELV transformer
- IPX4 rated double insulated fan. ABS housing with detachable mounting foot
- Sealed for life maintenance free motor
- Safety thermal overload protection
- 3m of flexible ducting
- Duct ties
- Soffit / wall grille colour brown

BriteX Turbo

BX100+W white bezel

Ref. 91248AW

BX100+C chrome bezel

Ref. 91249AW

- Suitable for longer duct runs and larger bathrooms
- Stylish SELV rated air inlet with 50W sealed dichroic lamp
- SELV transformer
- IPX4 rated double insulated mixed flow inline fan. ABS housing with detachable mounting foot
- Sealed for life maintenance free motor
- Safety thermal overload protection
- 6m of flexible ducting
- Duct ties
- Soffit/wall grille colour brown

BriteX Turbo T

BX100+WT white bezel

Ref. 91250AW

BX100+CT chrome bezel

Ref. 91251AW

- Fan fitted with overrun timer adjustable from 3-15mins
- Fan typically connected to the bathroom lighting. Fan continues to run after the light has been switched Off
- Stylish SELV rated air inlet with 50W sealed dichroic lamp
- SELV transformer
- IPX4 rated double insulated mixed flow inline fan.
- ABS housing with detachable mounting foot
- Sealed for life maintenance free motor
- Safety thermal overload protection
- 6m of flexible ducting
- Duct ties
- Soffit / wall grille colour brown

Typical Specifications on page 128.
Wiring Diagrams on page 143.

Performance

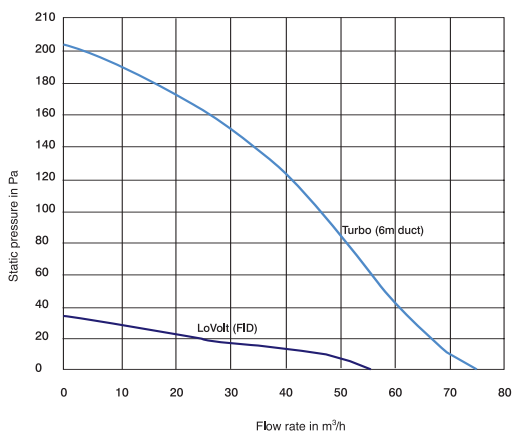

Dimensions

BriteX Range

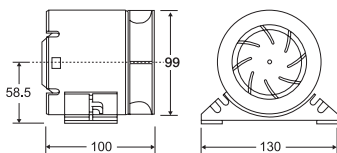

SELV Ceiling Bezel

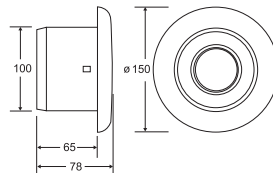

BriteX Turbo Range

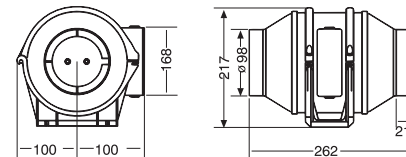

Installation

BriteX units can be installed with the inlet located in Zone 1 of a bath or shower in accordance with IEE regulations. The inlet bezel/light assembly fits flush to the ceiling. The fan is installed at the highest point in the duct run using the bracket provided to avoid a possible build up of condensation in the duct. It is good practice to cut off any surplus duct. Extended duct and radiused bends improve performance. The grille provided can be installed in the soffit of the roof or in a gable end wall.

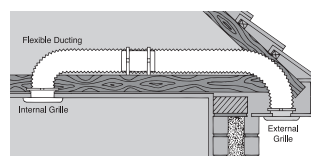

BriteX LoVolt Installation

Hole diameter: 102mm
Ducting size: 100mm

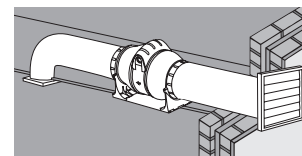

BriteX Turbo Installation

Hole diameter: 102mm
Ducting size: 100mm

Xpelair Profile 29 & Profile 25M

Flat duct systems



Key features

Type:	Low profile flat plastic & metal ducting
Application:	Particularly suitable for use with Premier DX180, DX200/400 & CF20/40 models.
Size options:	29mm plastic & 25mm metal
Installation:	Simple push fit & easily concealed

The Range

The ideal ducting solution for a variety of domestic installations where ceiling or wall space is limited.

In many refurbishment projects walls or ceilings are battened to provide a narrow space for services such as plumbing electrical wiring and ventilation. Where space is limited **Profile** duct is ideal above kitchen wall units, in cavity walls and even under floors.

Xpelair **Profile 29** is an easy to assemble, push fit, modular ventilation duct system designed for flush mounted fan installation within a minimum gap of 50mm ceiling void. It is lightweight and easy to cut to length using a cross-cut saw. **Profile 29** systems are non reverberant and will not deteriorate in applications where high humidity is present.

The system includes a full range of vertical and horizontal bends including special adaptors for connection to the top and rear of Premier DX200 & CF20 centrifugal fans. The extensive range of accessories offers the flexibility to achieve almost any ducting configuration in particularly tight spaces.

Assembly is easy using push fit flat channel connectors and the system is held to the wall or ceiling using quick-fit support clips. The ducting can be terminated in a conventional wall grille or a choice of horizontal or soldier course airbricks, and is then simply concealed behind plasterboard.

Some applications call for traditional galvanised sheet steel ducting. For these applications **Profile 25M** metal flat ducting can be used. **Profile 25M** measures 230 x 25mm and is also available in an extensive range of interconnecting components. With a depth of only 25mm it is ideal for installation between the floor/ceiling slab and the plasterboard finish. It can be fixed to the ceiling/wall by suitable fixings through the continuous flange on either side. All joints should be sealed with a sealing compound.

Profile 60 flat plastic duct system is also available for installations where a particularly low profile duct is not required, or where longer duct runs are required.

Exploded diagram of flush mounted Premier DX200 installation

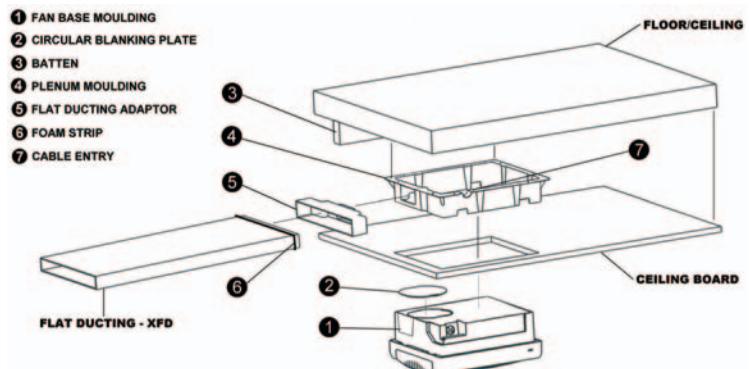

Profile 29 Flat Plastic Ducting - 234 x 29mm

Product	Product Ref	Description	Dimensions	Ref. No.
	XFD	Flat channel duct 1m	234 x 29	91104AA
		Flat channel duct 1.5m	234 x 29	91105AA
		Flat channel duct 2m	234 x 29	91106AA
	XFC	Flat channel connector	234 x 29	91107AA
	XFH90	Horizontal 90° bend	234 x 29	91108AA
	XFH45	Horizontal 45° bend	234 x 29	91109AA
	XFV90	Vertical 90° bend	234 x 29	91110AA
	XFV45	Vertical 45° bend	234 x 29	91111AA
	XFEP	Elbow bend/plenum 100mm spigot	234 x 29	91112AA
	XFRRRA	Round to rectangular adaptor 100mm spigot	234 x 29	91113AA
	XFS	Universal support clip		91114AA
	FDA	Flat ducting adaptor kit		90547AA
	XFLAA	Long airbrick adaptor	234 x 65	91102AA
	XFAF	Airbrick fascia terracotta	205 x 62	91103AA
		Airbrick fascia white	205 x 62	91126AA
		Airbrick fascia brown	205 x 62	91127AA
		Airbrick fascia cotswold stone	205 x 62	91128AA
	XFAS	Airbrick soldier course		91246AA
	XFWT	100mm telescopic wall tube		91247AA

Typical Specifications on page 128.

Dimensions

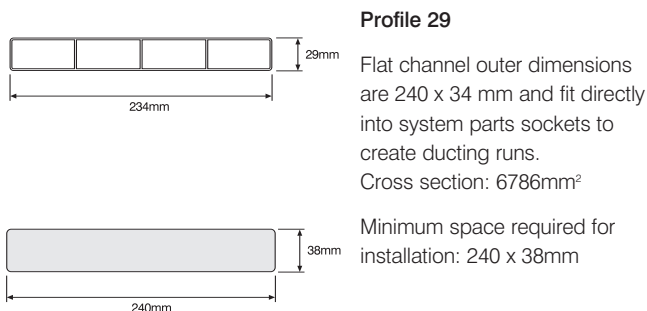

Profile 25M Flat Metal Ducting - 230x 25mm

Product	Product Ref	Description	Dimensions	Ref. No.
	FMD	Flat ducting 2.4 metre length	230 x 25	89758AA
	FMH90	Horizontal 90° bend	230 x 25	89759AA
	FMTB	Transition/air brick	230 x 25	89760AA
	FMP	Plenum box	230 x 25	89761AA
	FMV90	Vertical 90° bend	230 x 25	89762AA
	FMH45	Horizontal 45° bend	230 x 25	89763AA
	FMC	Coupling (boxed in 6's)	230 x 25	89764AA

Typical installation of Premier DX200 with Profile 29 ducting

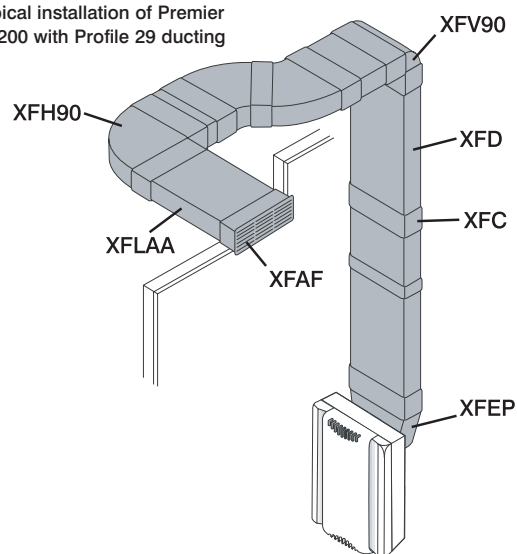

Profile 25M

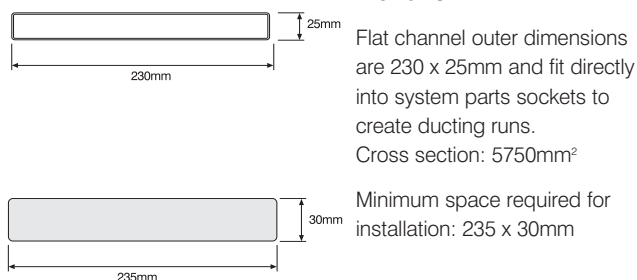

Xpelair XIM

Domestic inline mixed flow extract fans



Key features

Type:	Inline one or two speed mixed flow extract fans
Application:	Domestic bathrooms, shower rooms kitchens
Control options:	Standard or timer
Legislation:	Conforms to Building Regulations



The Range

Traditionally centrifugal ducted systems have been bulky and noisy. Well not any more. The new low profile Xpelair **XIM** units provide plenty of useable power for domestic ducted applications and save on space too. The seven models in the range are ideal for ducted applications where space is limited, such as in bathrooms, shower rooms, kitchens and other internal rooms without opening windows.

Available in four sizes, the new Xpelair **XIM** range of plastic mixed flow units offers duties for a wide range of ducted applications. They are dimensionally smaller than centrifugal units and with lower sound levels these units can often eliminate the need for a silencer. The two T models have a timer overrun adjustable from 3 to 15 minutes. Larger units have two speeds.

All models come complete with a convenient mounting cradle which makes installation or subsequent inspection simple. The terminal box is easily accessible simplifying the electrical connection. **XIM** units are either IPX2 or IPX4. Those rated IPX4 can be used in wet room ducted applications. Their plastic construction will not deteriorate in high humidity conditions. They are double insulated and suitable for operation on a supply voltage 220 - 240V 50Hz. All motors are maintenance free with greased for life bearings, and have safety overload protection.

Select the right product for your application

	XIM100	XIM100T	XIM100+	XIM125	XIM150	XIM150T	XIM200
Reference number	91252AW	91253AW	91254AW	91255AW	91256AW	91257AW	91258AW
Speeds	1	1	2	2	2	2	2
Remote switch (supplied separately)	■		■		■		■
Integral timer (adjustable from 3-15 mins)		■		■		■	
Max extract performance (FID m ³ /h)	77	77	251	265	476	476	845
Min extract performance (FID m ³ /h)			190	198	358	358	599
Max extract performance (FID l/s)	21	21	70	74	132	132	235
Min extract performance (FID l/s)			53	55	99	99	166
Sound pressure level (dB(A)@3m)	55	55	55	55	56	56	58
Electrical power rating (W)	25	25	25	25	80	80	75
Weight (kg)	1.2	1.2	2.1	2.1	3.2	3.2	4.5
Duct size (mm)	100	100	100	125	150	150	200
IP rating	IPX2	IPX2	IPX4	IPX4	IPX4	IPX4	IPX4
Guarantee (years, UK)	2	2	2	2	2	2	2

Models

XIM100

Ref. 91252AW

- Single speed inline fan
- Mixed flow impeller/guide vanes
- Integral mounting cradle
- Rated at IPX2

XIM100T

Ref. 91253AW

- Single speed inline fan with adjustable overrun timer from 3-15mins
- Timer located in the terminal box
- Triggered by lighting circuit
- Mixed flow impeller/ guide vanes
- Integral mounting cradle
- Rated at IPX2

XIM100+

Ref. 91254AW

- High performance 2 speed inline fan
- Mixed flow impeller/guide vanes
- Integral mounting cradle
- Rated at IPX4

XIM125

Ref. 91255AW

- 2 speed inline fan
- Mixed flow impeller/guide vanes
- Integral mounting cradle
- Rated at IPX4

XIM150

Ref. 91256AW

- 2 speed inline fan
- Mixed flow impeller/guide vanes
- Plastic construction
- Integral mounting cradle
- Rated at IPX4

XIM150T

Ref. 91257AW

- Adjustable overrun timer from 3-15mins
- 2 speed inline fan
- Timer located in the terminal box
- Timer triggered by lighting circuit
- Mixed flow impeller/guide vanes
- Integral mounting cradle
- Rated as IPX4

XIM200

Ref. 91258AW

- 2 speed inline fan
- Mixed flow impeller/guide vanes
- Integral mounting cradle
- Rated as IPX4

Performance

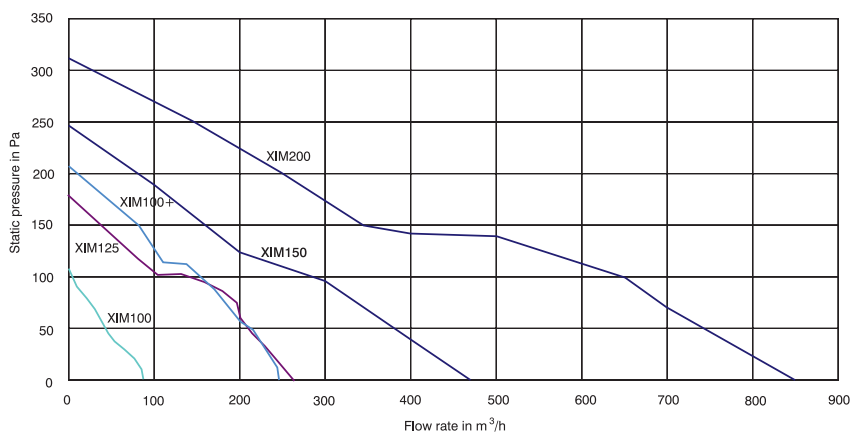

Controllers

Change Over Switch COS

Ref. 90108AW

- Provides High-Low speed operation
- Surface or recess mounting
- 85 x 85mm

Typical Specifications on page 129.
Wiring Diagrams on page 143.

Dimensions

XIM100/100+/125

XIM150/200

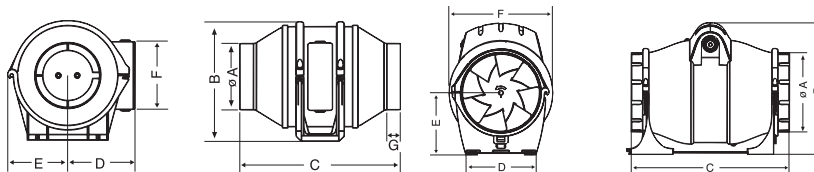

Model	Dimensions (mm)						
	ØA	B	C	D	E	F	G
XIM100	98	177	238	99.5	89.2	100	20
XIM100+	98	217	262.4	100	100	168.3	21.3
XIM125	122	217	262.4	100	100	168.3	21.3
XIM150	147	244	293.4	130	115	192.3	21.3
XIM200	197	278.5	363.6	142	140	230.2	51.5

Installation and Accessories

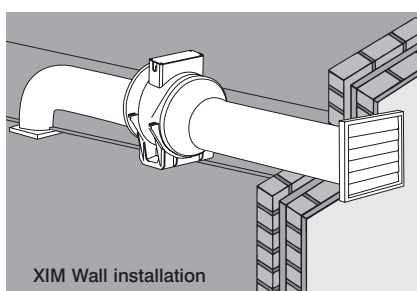

XIM Wall installation

Installation Accessories

Wall Mounting

- Flexible Ducting Xflex FD100 (3m) Ref. 89663AA
- Flexible Ducting Xflex FD125 (3m) Ref. 89664AA
- Flexible Ducting Xflex FD150 (3m) Ref. 89665AA
- Flexible Ducting Xflex FD200 (3m) Ref. 89666AA
- Wall grille CFWG100 Ref. 89742AW
- Wall grille CFWG150 Ref. 89857AW

Xflex FD also available in longer length (see page 45)
Wall grille CFWG also available in grey