



E3 Clad for Composite Doors

CONTENTS

E3 Clad – Special Design .....	1
Architectural Detail .....	2
Hardware Selection .....	6
Surelock Adjustment .....	15

# ADDRESSES THE UNIQUE REQUIREMENTS OF COMPOSITE DOORS



## E3 CLAD – EXTRAORDINARY POTENTIAL

Created to address the unique requirements of composite door manufacturers and fabricators, E3 CLD brings the extraordinary potential of Centor's surface-mounted folding hardware to the rapidly expanding market for aluminum-clad timber doors.

Specifically designed for composite door panels with hinges and carriers fastened directly to the door panel edges, E3 CLD rethinks screw-hole position, offsets and panel gap allowances from the versatile E3 system to optimize use of this ground-breaking technology in mixed-material applications.

Retaining each of E3's acclaimed features, E3 CLD gives specifiers and door manufacturers complete freedom in door set design; inward or outward opening, any odd or even combination of identically-sized panels, all with unparalleled performance from a super-smooth, top-hung system.

E3 Clad Specifications	
<b>max opening</b>	
<b>max panel weight</b>	
<b>max panel height</b>	
<b>max panel width</b>	
<b>max panel thickness</b>	18mm
<b>max number of panels</b>	

## TECHNICAL DETAIL

### CLADDING DETAILS

These hinges are made for cladding with a maximum thickness of 18mm. This includes the offset from panel to cladding.

1. panel gaps – 8mm
2. offset distance – 8.8mm
3. minimum panel size – 57mm
4. seal recommendations – AQ33, AQ63, AQ21, QEZ345 and AQ109 (access panel only)
5. hinge leaf extension – 55.35mm

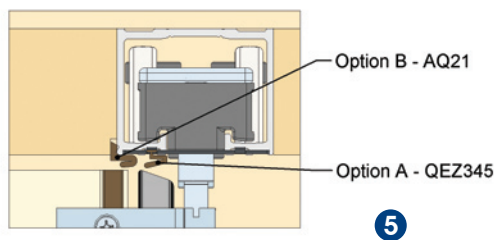
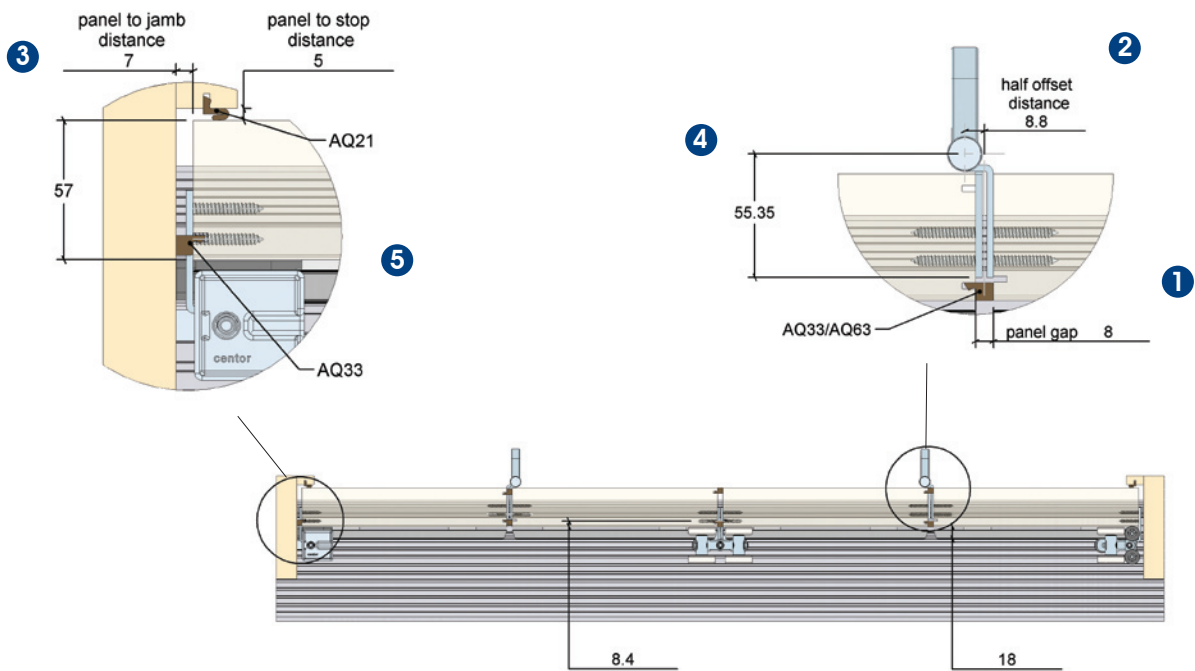

Two head sealing options are offered for the clad hinges.  
 Option A – QEZ345 in track seal provision.  
 Option B – AQ21 in timber slot next to track.

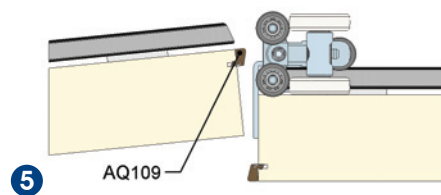

AQ109 is to be used on a meeting panel. The shape of this seal stops the incoming door from pushing the seal out of shape.

TECHNICAL DETAIL – SCREW HOLE POSITIONS

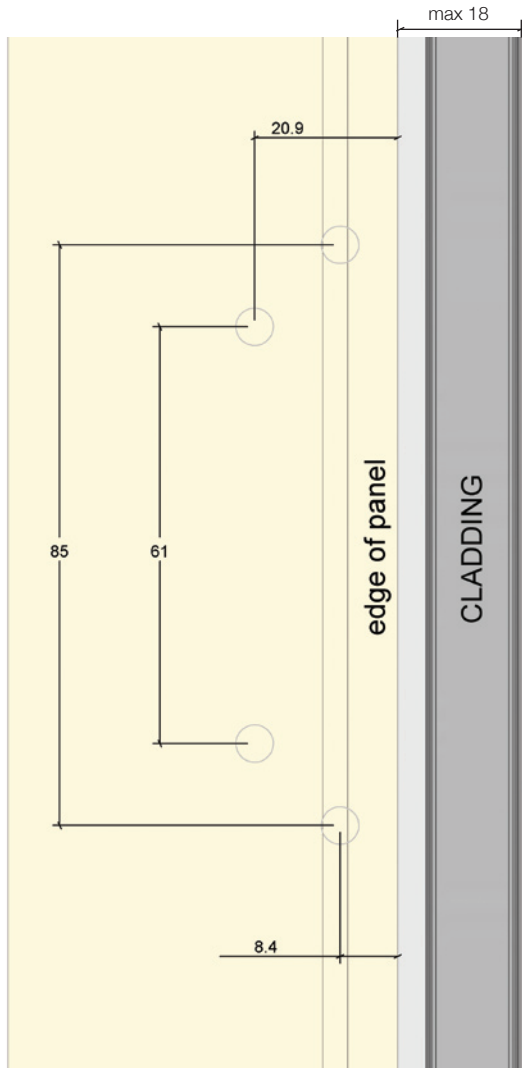

**CARRIERS AND PIVOTS**  
(shown for outward opening configurations)

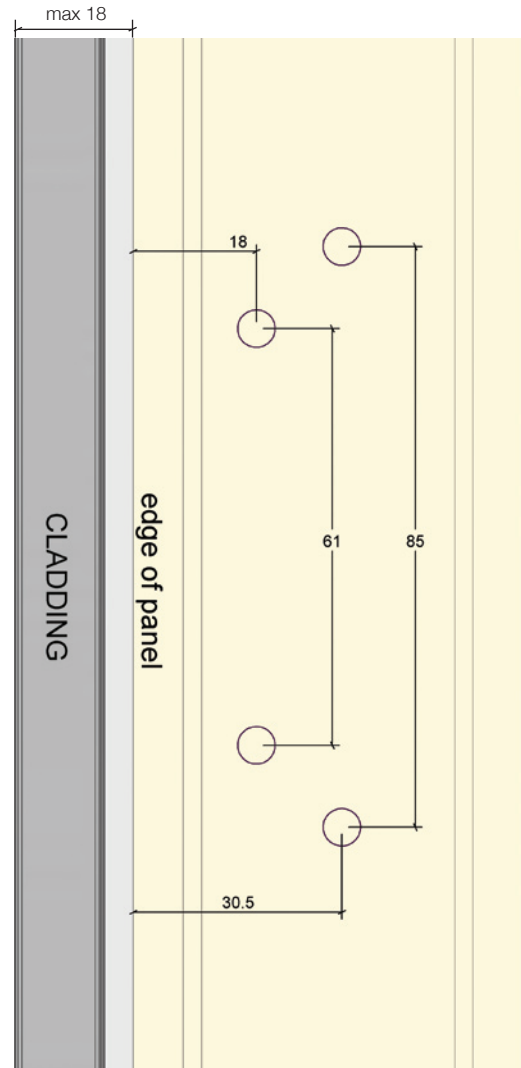

**HINGES**  
(shown for outward opening configurations)

The screw hole positions are the same as E3 relative to the timber panel.

ARCHITECTURAL DETAIL

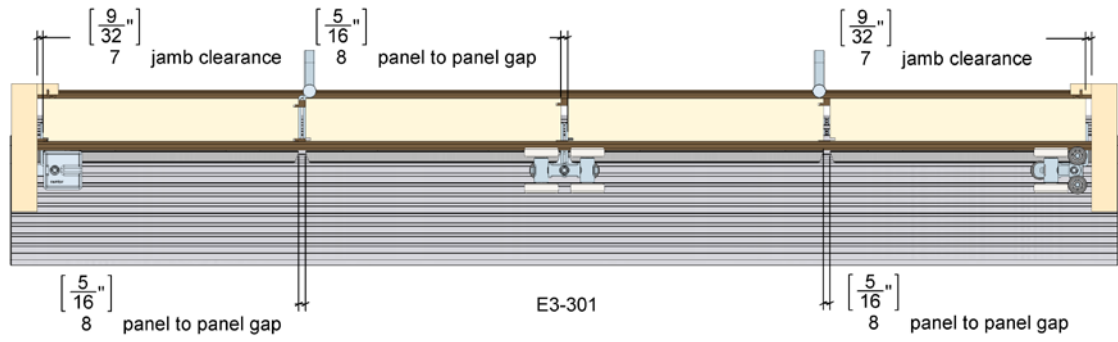

ARCHITECTURAL DETAIL

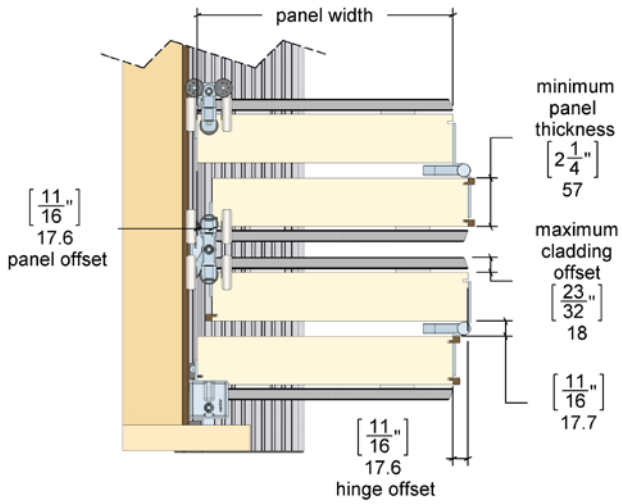

E3-303

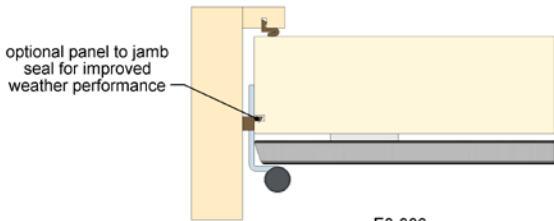

E3-306

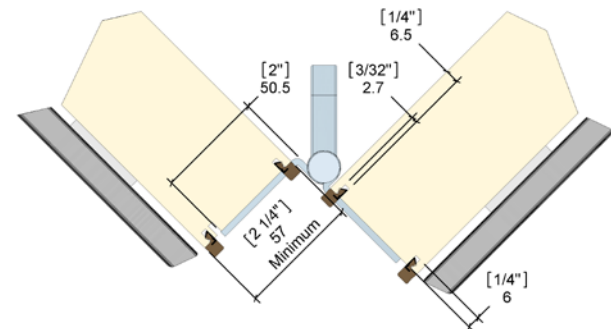
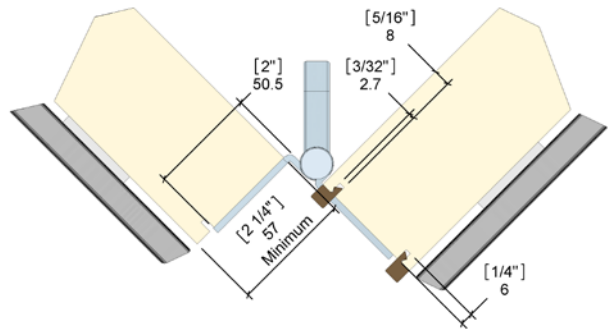

E3-307

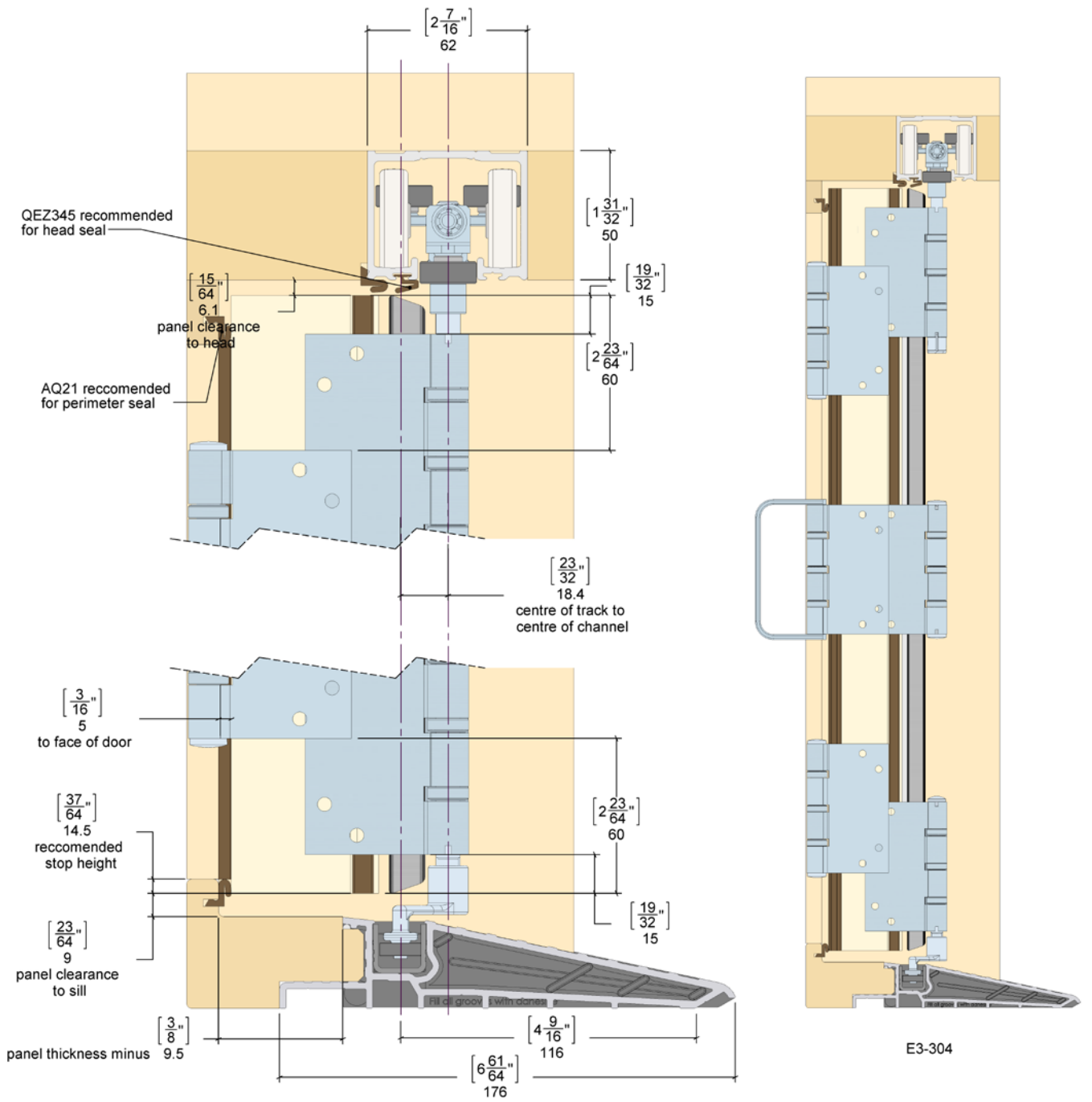



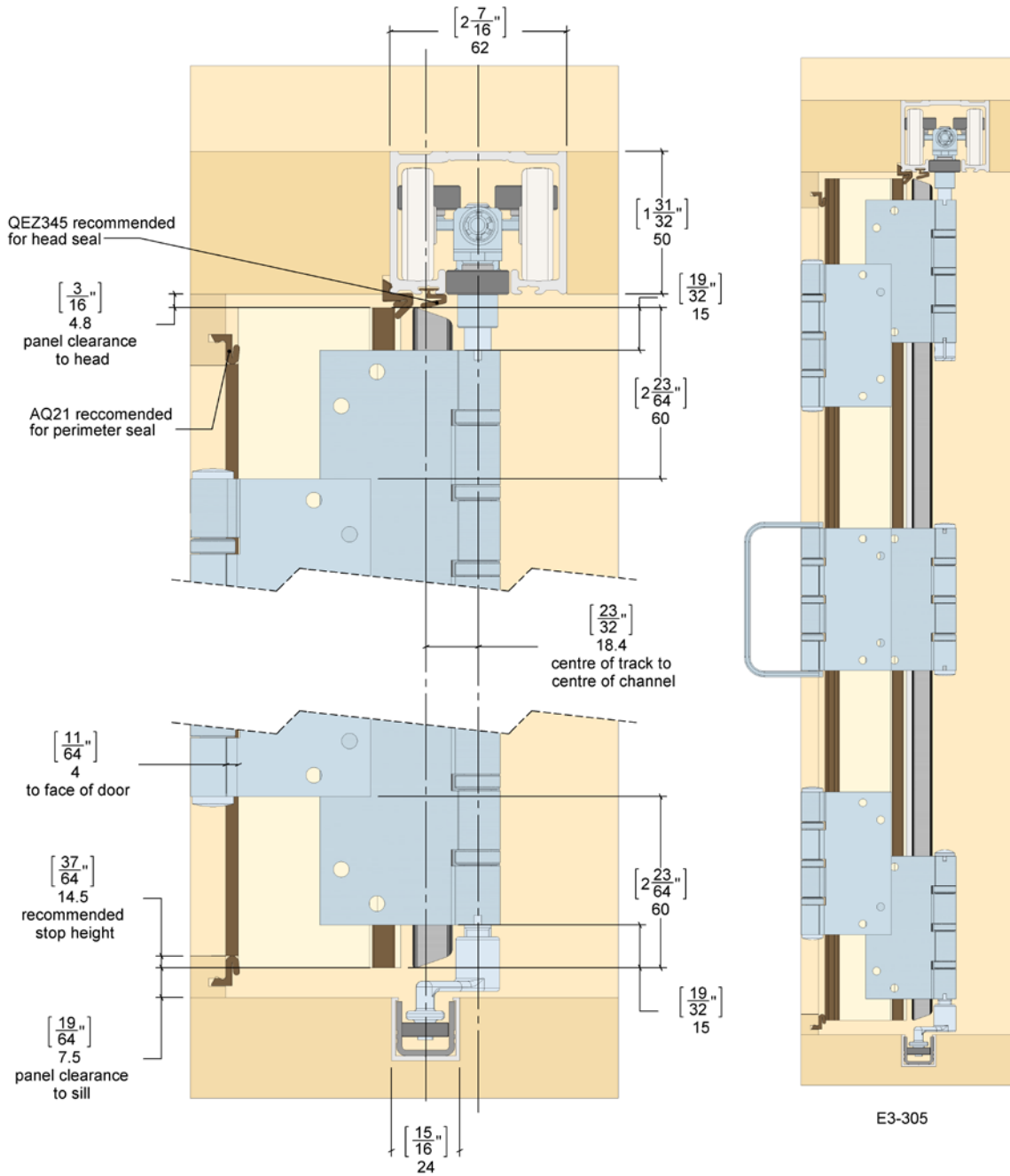

## HARDWARE SELECTION

E3 Clad is specified with 5 separate groups:

- 1 track
- 2 sill with channel
- 3 hardware
- 4 weathersealing
- 5 dropbolts

Components are required from all 5 groups to build an E3 Clad folding door system.

### TRACK

Track lengths up to 5.7m. Cut to length on application.

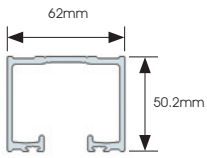
PART	TRACK	PRODUCT CODE	DESCRIPTION
	Aluminium track, machined	E3TAM18N	1730mm machined track, natural anodised
		E3TAM21N	2030mm machined track, natural anodised
		E3TAM24N	2330mm machined track, natural anodised
		E3TAM30N	2930mm machined track, natural anodised
		E3TAM36N	3530mm machined track, natural anodised
		E3TAM4N	4000mm machined track, natural anodised
		E3TAM42N	4130mm machined track, natural anodised
		E3TAMM57N	5700mm machined both ends track, natural anodised
		E3TAM24G	2330mm machined track, gold anodised
		E3TAM30G	2930mm machined track, gold anodised
		E3TAM4G	4000mm machined track, gold anodised
		E3TAMM57G	5700mm machined both ends track, gold anodised
		E3TAM30R	3000mm machined track, bronze anodised
		E3TAM4R	4000mm machined track, bronze anodised
		E3TAMM57R	5700mm machined both ends track, bronze anodised

### OUTWARD CONCEALED SILL

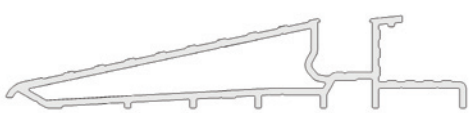
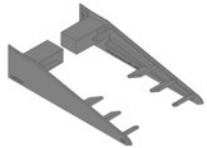
PARTS	PRODUCT CODE	DESCRIPTION
	E3CDSM36N	3600mm concealed sill, machined, natural anodised
	E3CDSM42N	4200mm concealed sill, machined, natural anodised
	E3CDSM57N	5700mm concealed sill, machined, natural anodised
	E3CDSM36R	3600mm concealed sill, machined, bronze anodised
	E3CDSM42R	4200mm concealed sill, machined, bronze anodised
	E3CDSM57R	5700mm concealed sill, machined, bronze anodised
	E3CDSEC	end cap set (left and right)





## HARDWARE SELECTION

### CHANNEL

PARTS	CHANNEL	PRODUCT CODE	DESCRIPTION
	Concealed channel 21mm, poly channel	E22FCP18	1800mm floor channel, polypropylene
		E22FCP21	2100mm floor channel, polypropylene
		E22FCP24	2400mm floor channel, polypropylene
		E22FCP30	3000mm floor channel, polypropylene
		E22FCP36	3600mm floor channel, polypropylene
		E22FCP4	4000mm floor channel, polypropylene
		E22FCP42	4200mm floor channel, polypropylene
		E22FCP57	5700mm floor channel, polypropylene
	Concealed channel 24mm, retainer	E22FCR24N	2400mm floor channel retainer, natural anodised
		E22FCR3N	3000mm floor channel retainer, natural anodised
		E22FCR36N	3600mm floor channel retainer, natural anodised
		E22FCR4N	4000mm floor channel retainer, natural anodised
		E22FCR57N	5700mm floor channel retainer, natural anodised
		E22FCR24G	2400mm floor channel retainer, gold anodised
		E22FCR3G	3000mm floor channel retainer, gold anodised
		E22FCR36G	3600mm floor channel retainer, gold anodised
		E22FCR4G	4000mm floor channel retainer, gold anodised
		E22FCR57G	5700mm floor channel retainer, gold anodised
		E22FCR3R	3000mm floor channel retainer, bronze anodised
		E22FCR4R	4000mm floor channel retainer, bronze anodised
		E22FCR57R	5700mm floor channel retainer, bronze anodised



## HARDWARE SELECTION

### WEATHERSEAL

PART	PRODUCT CODE	PART DESCRIPTION
Perimeter 	AQ21B	Aquamac 21 Schlegel Kerf seal, brown
	AQ21L	Aquamac 21 Schlegel Kerf seal, black
	AQ21W	Aquamac 21 Schlegel Kerf seal, white
Panel to panel 	AQ63B	Aquamac 63 Schlegel Kerf seal, brown
	AQ63L	Aquamac 63 Schlegel Kerf seal, black
	AQ63W	Aquamac 63 Schlegel Kerf seal, white
Access panel 	AQ109B	Aquamac 109 Schlegel Kerf seal, brown
	AQ109L	Aquamac 109 Schlegel Kerf seal, black
	AQ109W	Aquamac 109 Schlegel Kerf seal, white
Head 	QEZ345B	Aquamac 345, head seal, brown
	QEZ345L	Aquamac 345, head seal, black
	QEZ345W	Aquamac 345, head seal, white
		

## HARDWARE SELECTION

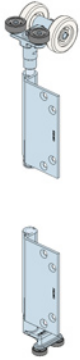
### RIGHT CARRIER SET



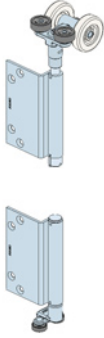
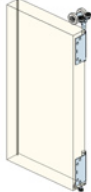

PARTS	PARTS ON PANELS	PRODUCT CODE	DESCRIPTION
		E3CRCSS	concealed right hand carrier set, stainless steel
		E3CRCSTG	concealed right hand carrier set, PVD brass
		E3CRCSQ	concealed right hand carrier set, oil rubbed bronze powdercoat

### LEFT CARRIER SET

PARTS	PARTS ON PANELS	PRODUCT CODE	DESCRIPTION
		E3CLCSS	concealed left hand carrier set, stainless steel
		E3CLCSTG	concealed left hand carrier set, PVD brass
		E3CLCSQ	concealed left hand carrier set, oil rubbed bronze powdercoat

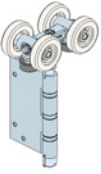
## HARDWARE SELECTION

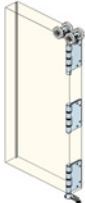
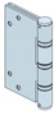
### INTERMEDIATE CARRIER SET (FOURTH HINGE RECOMMENDED FOR DOORS OVER 2250MM)

PARTS		PARTS ON PANELS	PRODUCT CODE	DESCRIPTION
a)	b)	a)	E3CICSS	concealed intermediate set, stainless steel
			E3CICSTG	concealed intermediate set, PVD brass
			E3CICSQ	concealed intermediate set, oil rubbed bronze powdercoat
			<b>Fourth Hinge</b>	
		b)	E3HNHS	single straight hinge, stainless steel
			E3HNHTG	single straight hinge, PVD brass
			E3HNHQ	single straight hinge, oil rubbed bronze powdercoat



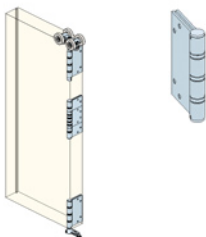



a) intermediate carrier set with concealed bottom guide  
 b) fourth hinge recommended for doors over 2250mm

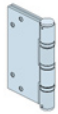

where do these drawings go?

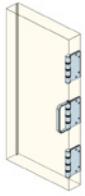
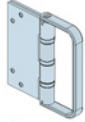
## HARDWARE SELECTION

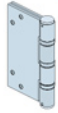
### STRAIGHT HINGE SET

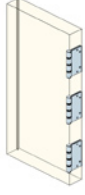
PARTS		PARTS ON PANELS	PRODUCT CODE	DESCRIPTION
a)	b)	a)	E3HSS	hinge set with handle, stainless steel
			E3HSTG	hinge set with handle, PVD brass
			E3HSQ	hinge set with handle, oil rubbed bronze powdercoat
		b)	E3HNHSS	hinge set no handle, stainless steel
			E3HNHSTG	hinge set no handle, PVD brass
			E3HNHSQ	hinge set no handle, oil rubbed bronze powdercoat





a) hinge set with handle for outward opening doors  
 b) hinge set no handle for inward opening doors

### SINGLE HINGE (FOURTH HINGE RECOMMENDED FOR DOORS OVER 2250MM)

PARTS	PRODUCT CODE	DESCRIPTION
	E3HNHS	single straight hinge, stainless steel
	E3HNHTG	single straight hinge, PVD brass
	E3HNHQ	single straight hinge, oil rubbed bronze powdercoat

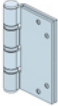
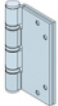
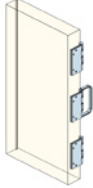
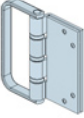
## HARDWARE SELECTION

### STRAIGHT HINGE SET

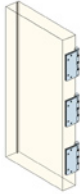
PARTS		PARTS ON PANELS	PRODUCT CODE	DESCRIPTION
a)	b)	a)	E3HSS	hinge set with handle, stainless steel
			E3HSTG	hinge set with handle, PVD brass
			E3HSQ	hinge set with handle, oil rubbed bronze powdercoat
		b)	E3HNHSS	hinge set no handle, stainless steel
			E3HNHSTG	hinge set no handle, PVD brass
			E3HNHSQ	hinge set no handle, oil rubbed bronze powdercoat

a) hinge set with handle for outward opening doors  
b) hinge set no handle for inward opening doors

### SINGLE HINGE (FOURTH HINGE RECOMMENDED FOR DOORS OVER 2250MM)

PARTS	PRODUCT CODE	DESCRIPTION
	E3HNHS	single straight hinge, stainless steel
	E3HNHTG	single straight hinge, PVD brass
	E3HNHQ	single straight hinge, oil rubbed bronze powdercoat



## SURELOCK™ ADJUSTMENT

### PIVOT SET / WALL PIVOT

Wall pivots are mandatory on door panels over 2150mm. Wall pivots are strongly recommended on all door panels in wet or humid climates, exposed locations, inward opening applications and unstable timber doors. A second pivot can be used on door panels over 2250mm to match the additional row of hinges.

PARTS	PARTS ON PANELS	PRODUCT CODE	DESCRIPTION
	a)	E3CPSS	concealed pivot set, stainless steel
		E3CPSTG	concealed pivot set, PVD brass
		E3CPSQ	concealed pivot set, oil rubbed bronze powdercoat
	b)	E3WPSS	wall pivot set, stainless steel
		E3WPSTG	wall pivot set, PVD brass
		E3WPSQ	wall pivot set, oil rubbed bronze powdercoat
	c)		

a) pivot set

b) pivot set and jamb mounted middle wall pivot mandatory on door panels over 2150mm to prevent/control deflection and bowing

c) pivot set and two wall pivots to match hinge pattern on door panels over 2250mm

## SURELOCK™ ADJUSTMENT

Surelock™ is Centor's patented carrier pin locking system which ensures that once door heights are set at the top pivots, intermediate and end carriers, they stay set!

- 1 Components come supplied with a plastic shipping clip installed.
  - 2 Insert a flat-bladed screwdriver into the slot and rotate the pin.
  - 3 When correct adjustment is reached remove the shipping clip.
  - 4 Surelock™ will snap into place when the blade and slot are aligned.
  - 5 To readjust pull the blade down to disengage it from the slot, replace the shipping clip and rotate the pin.
- Remove shipping clip after final installation adjustment.

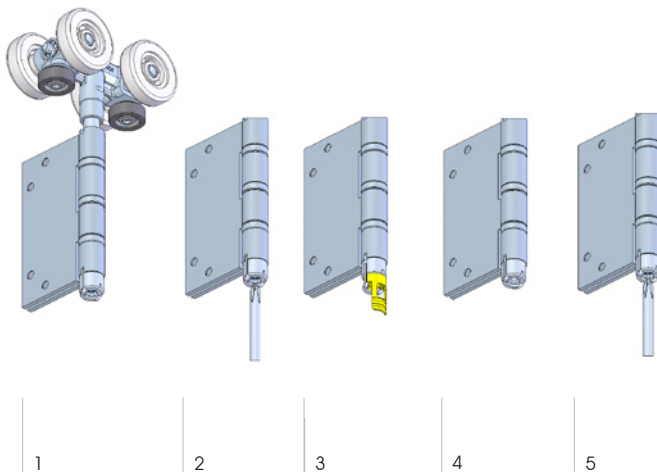

## LATERAL ADJUSTMENT

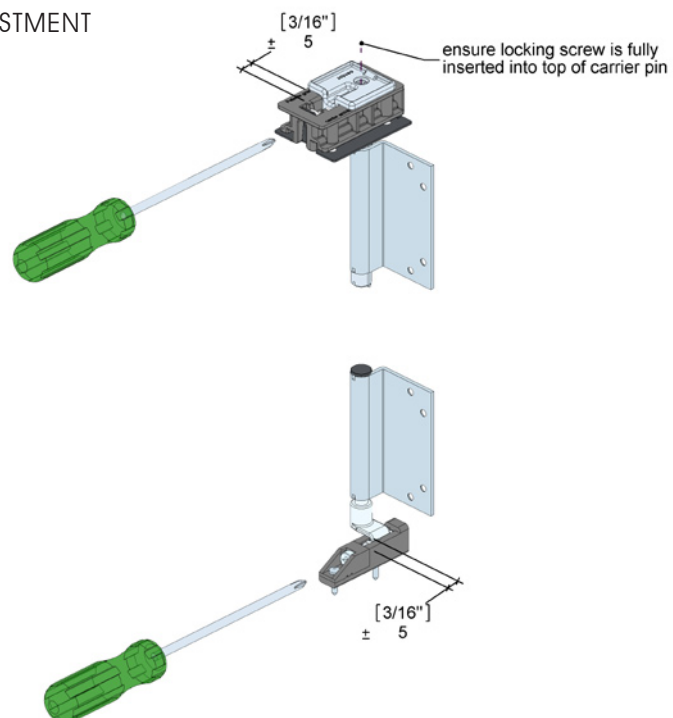





**Centor Europe**

Unit 10 Monkspath Business Park  
Highlands Road  
Solihull  
B90 4NY  
United Kingdom  
telephone +44 (0)121 701 2500  
facsimile +44 (0)121 701 2515  
mail@centor.eu  
www.centor.eu

