

O₂MAX SURFACE AERATORS

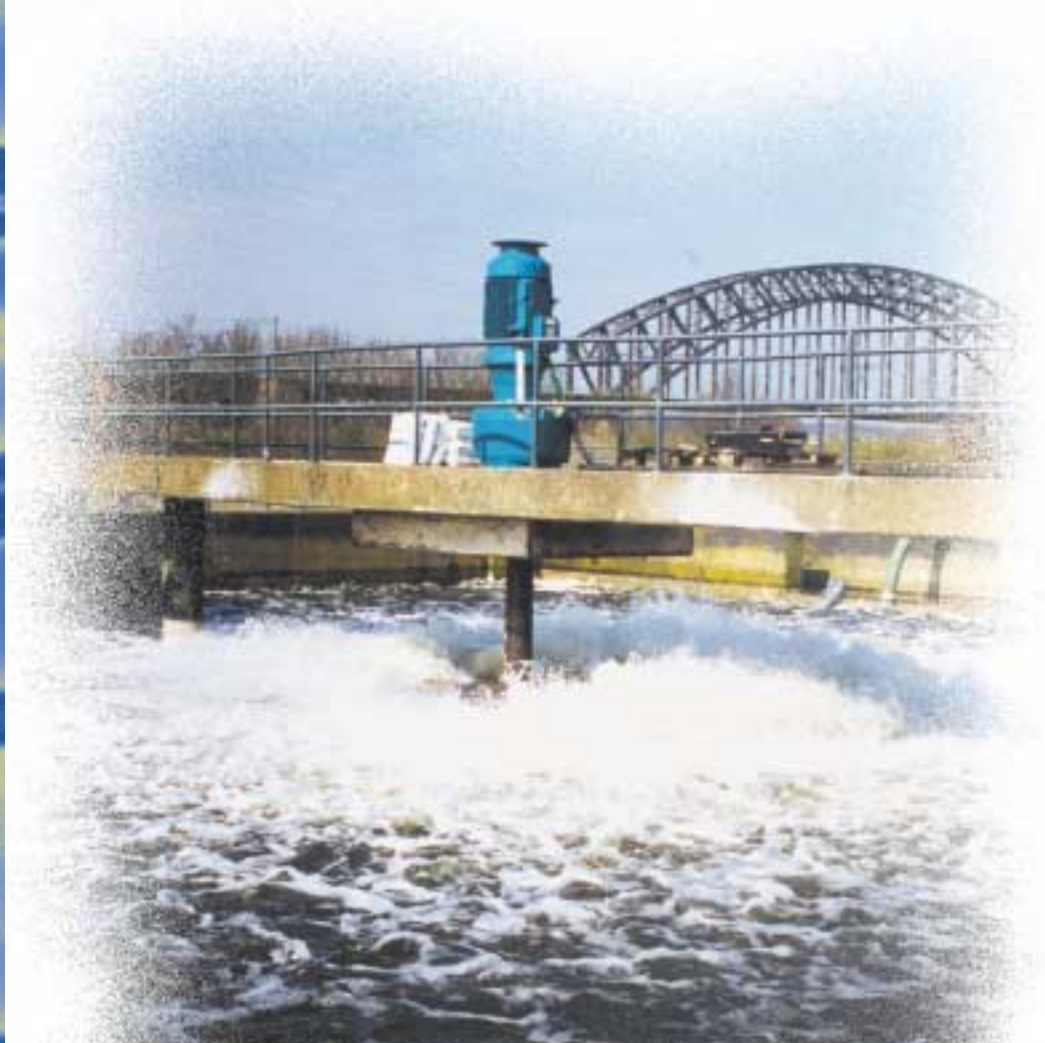

Spaans Babcock

Surface aerators

Spaans Babcock introduced the O2Max in 1999. This new generation of energy saving surface aerator is capable of optimising the biological treatment phase of the waste water treatment process.

Performance

The design of the O2Max guarantees a very high aeration efficiency which, depending on the diameter and the tank shape can be up to 3 kg O₂/kWh nett. The unique shape of the O2Max gives energy savings up to 20% compared with existing mechanical low speed surface aerators.



Design

The design of the impeller reduces the forces exerted by the water, the related frictional forces are therefore very low compared to traditional cone shaped surface aerators. The up-thrust is substantially lower than the weight of the impeller. This ensures a quiet and vibration free operation which results in a longer life time of the drive unit and a reduction of the forces on the civil structure.

The blade is designed such that it is non-clogging. This prevents particulate build-up on the aerator blade thereby reducing maintenance costs.

Whilst maintaining a high efficiency the oxygen versus power input are adjustable over a full range of immersion depths and speed.

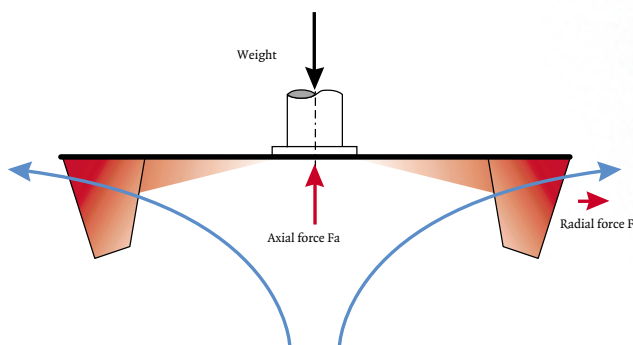

Splash pattern

The splash pattern of the O2Max is very fine and smooth with a relatively low height and small diameter. For new installations this will reduce initial investment in the civil construction.

O2Max type / diameter (cm)	maximum splash pattern (m)	
	height	diameter
100 - 120	0.8	8
130 - 180	0.9	9
190 - 240	1	10
250 - 280	1.1	11
290 - 340	1.2	12

*splash pattern
O2Max aerator*



Flexibility

The excellent mixing and propulsion capacity allows the O2Max to be applied in all types of aeration systems such as complete mix, SBR, oxidation ditches and lagoons. The O2max can be supplied in 2 different options: either as a fixed arrangement for mounting on a concrete or steel bridge or as a floating unit.

Advantages

- High aeration efficiency
- Energy savings possible
- Cost savings possible
- Fine and smooth splash pattern
- Very low reaction forces
- Quiet and vibration free operation
- Interchangeable with all other types of low speed aerators



oxidation ditch

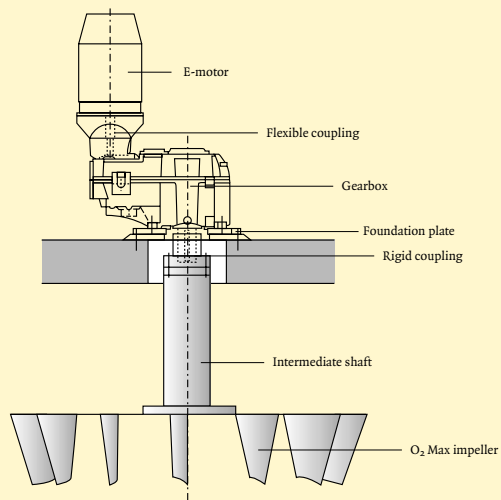
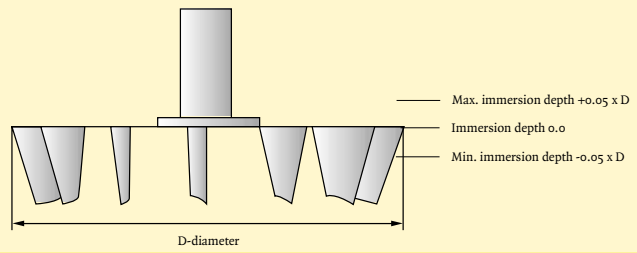

Selection

A wide range of diameters ensures that for every oxygen demand the most optimal and efficient aerator configuration can be selected. This means that for every application a suitable solution is available.

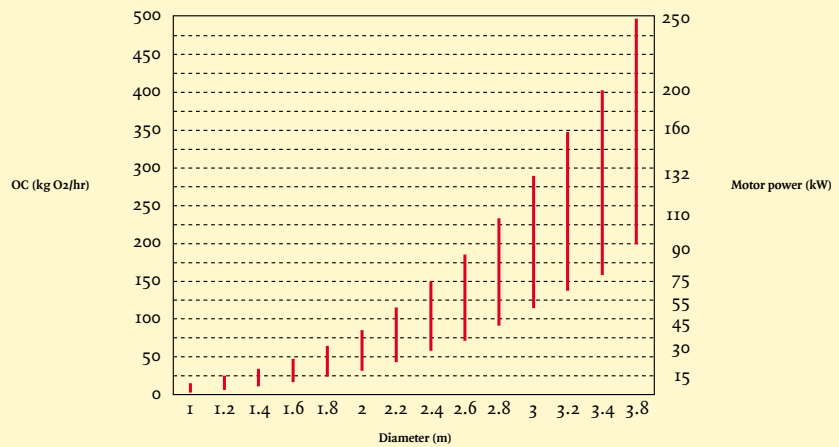

Spaans Babcock bv

P.O. Box 79
8560 AB Balk
The Netherlands

Meerweg 26
8561 AV Balk
The Netherlands

Tel. +31 (0)514 60 82 82
Fax +31 (0)514 60 44 85

E-Mail
sales@spaansbabcock.nl
Internet
www.spaansbabcock.com

Commercial register
Amsterdam 34004868

