

THORN

Qba

Compact projector for discreet facade illuminations



Qba

A compact discharge projector for the feature lighting of building facades, architectural details, monuments and statues



Qba is a simple yet modern floodlight, available in two sizes and featuring precision reflector systems which can provide intensive or extensive, disymmetrical or asymmetrical beam patterns. The luminaire itself is designed to blend discreetly into modern or traditional building surroundings and is mounted using a cleverly concealed stirrup.

Qba is available as standard in grey powder coated finish or to order in brick red or pale sand finishes where a visual blend with the building is important. All other RAL colours are also available on request.

In addition to the lighting effect choices offered by the reflectors, accessories such as colour filters, louvre, visor and barndoors further extend the possibilities for lighting design.



Definition

Performance

Reflector Beam shape

Radially Symmetric (Intensive)



Radially Symmetric (Extensive)



Disymmetric



Asymmetric

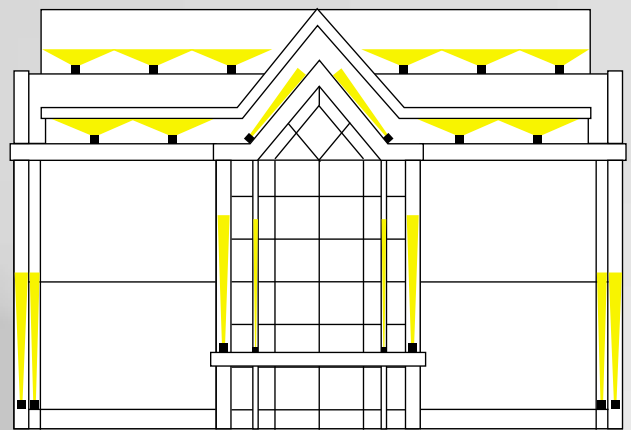
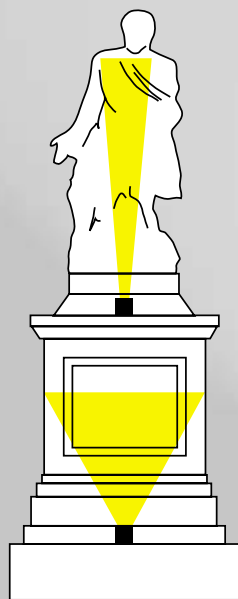
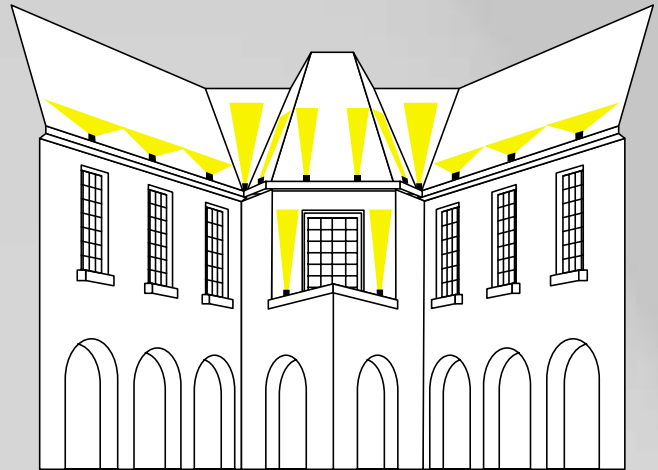
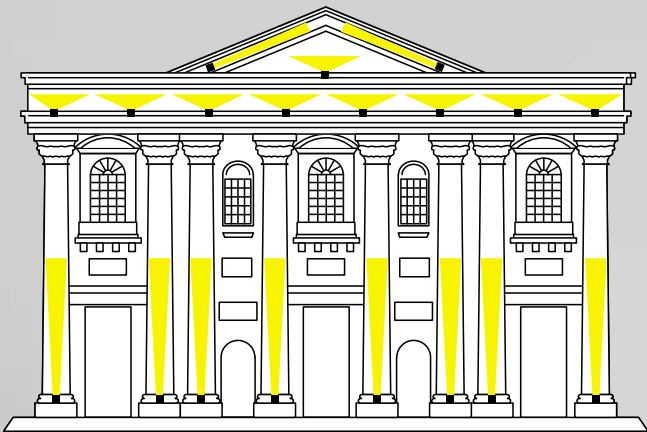



Lamps

- ☛ 35/70W/150W HIT metal halide (MT), cap: G12 or HIT-CE (MT//C), cap: G12
- ☛ 70W/150W HIT-DE double ended metal halide (MD) or HIT-DE-CE (MD//C), cap: Rx7s
- ☛ 70W/150W HST-DE high pressure sodium (SD), cap: Rx7s

Materials/Finish

Body: Die-cast aluminium, grey powder coated finish. Brick red and pale sand colour versions on request.
 Body screws: stainless steel
 Front lens: 4mm toughened glass
 Attachment retaining screws: Nickel plated brass
 Accessory frames: die cast aluminium

- Robust, die-cast aluminium body
- Two body sizes:
Size 1: 35 & 70W Size 2: 150W
- Choice of radial reflectors with intensive or extensive symmetrical beam, or cylindrical parabolic reflector with asymmetrical or disymmetrical distribution
- Choice of metal halide or high pressure sodium lamps, 35W to 150W



- Rectangular compact projector provides anonymity in building facade applications
- Rounded edges and concealed stirrup for contemporary and functional styling
- Alternative colours available to order for use on buildings where a visual blend is important

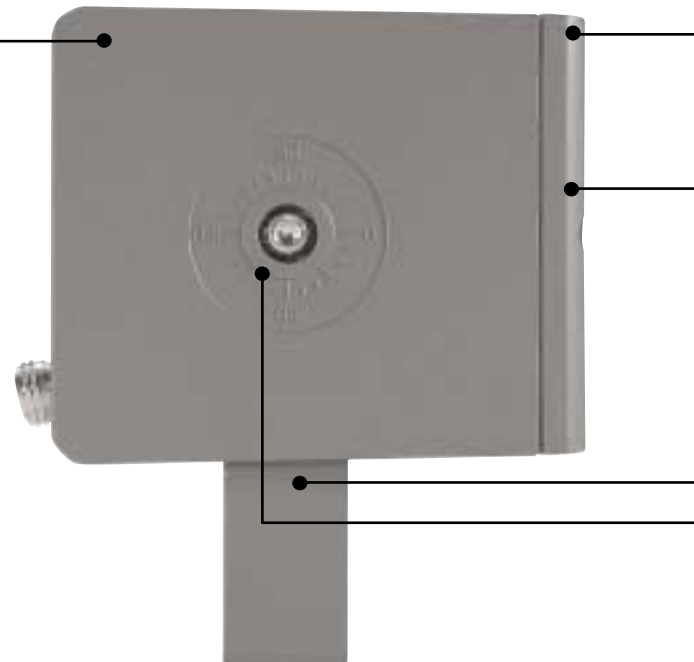
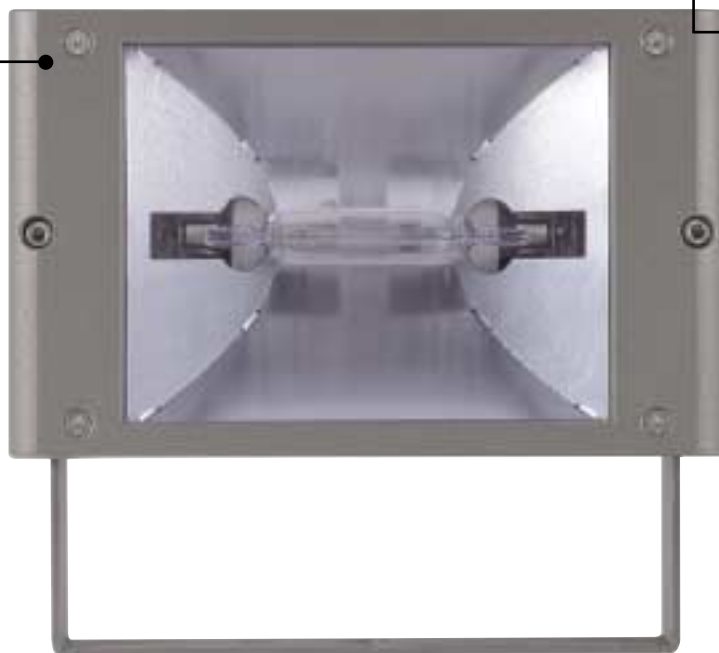

Installation/Mounting

Floodlight is adjustable on a short stirrup. Aiming simplified by indicator on stirrup, locked via central 8mmØ Allen screw. Easy access to lamp via 2 Allen screws. Lamp replacement possible without removing attachments. Control gear compartment, with rear access panel, entry via two Allen screws. Cable gland for 7.5-13mm² cable. Additional knock out provided for through wiring.

Standards

Designed and manufactured to comply with EN 60598.
 ⚡⚡⚡ IP65 CE
 IK08 (6 joules)
 850° hot wire. Ta (max) 25°C
 Electrical Class 1

Specification

To specify state:
 Rectangular compact projector in die-cast aluminium with concealed stirrup and asymmetrical/dissymmetrical/radially intensive/radially extensive optical system for HIT, HIT-DE or HPS-DE lamps.
 As Thorn Qba



- Easy access to lamp without removing accessories
- Accessory frame integrates into the body's round edges for design continuity
- Through wiring facility

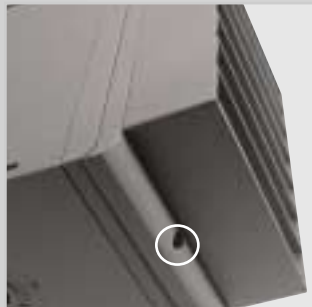

- Wide selection of accessories which can be "stacked" to provide a variety of lighting effects including:

- Visor
- Wire guard
- Barndoor
- Louvre
- Colour filters



- Concealed stirrup
- Aiming simplified by indicator on stirrup

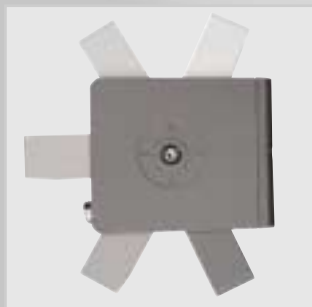

Ordering guide

Dimensions

Accessories



Size 1

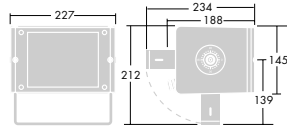

Size 2

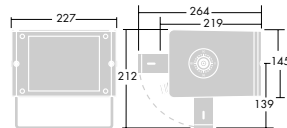

Ordering Guide Lamps to be ordered separately

Description	Ilcos Code	Socket	Wt (Kg)	EAN Code 230V	EAN Code 240V
Size 1					
Qba1 R EXT HIT 35	MT35	G12	4.7	3413832153665	3413832153658
Qba1 R INT HIT 35	MT35	G12	4.7	3413832153689	3413832153672
Qba1 R EXT HIT 70	MT70	G12	4.9	3413832153627	3413832153610
Qba1 R INT HIT 70	MT70	G12	4.9	3413832153641	3413832153634
Qba1 ASYM HPS/DE 70	SD70	RX7s	4.9	3413832153542	3413832153535
Qba1 SYM HPS/DE 70	SD70	RX7s	4.9	3413832153566	3413832153559
Qba1 ASYM HIT/DE 70	MD70	RX7s	4.9	3413832153580	3413832153573
Qba1 SYM HIT/DE 70	MD70	RX7s	4.9	3413832153603	3413832153597

Size 2					
Qba2 R EXT HIT 150	MT150	G12	6.3	3413832153795	3413832153788
Qba2 R INT HIT 150	MT150	G12	6.3	3413832153818	3413832153801
Qba2 ASYM HIT/HPS/DE 150	MD/SD70	RX7s	6.3	3413832153702	3413832153696
Qba2 SYM HIT/HPS/DE 150	MD/SD70	RX7s	6.3	3413832153726	3413832153719

Accessories	Wt	EAN Code
Qba Visor	0.5	3413832154891
Qba Wire guard	0.5	3413832154907
Qba Barndoors (set of 4)	0.6	3413832154914
Qba Louvre	0.7	3413832154921
Qba Colour filter, blue	0.4	3413832154874
Qba Colour filter, red	0.4	3413832154881
Qba Colour filter, green	0.4	3413832154898
Qba Colour filter, yellow	0.4	3413832154904
Qba Short stirrup for close wall mounting	0.5	3413832158141

R: Round EXT: Extensive, INT: Intensive, ASYM: Asymmetryic, SYM: Disymmetric



Visor



Wire guard

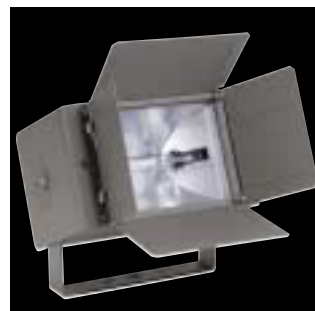

Barndoors



Louvre



Colour filter, blue



Colour filter, green



Colour filter, yellow



Colour filter, red

Photometric data

Technical

Fixing

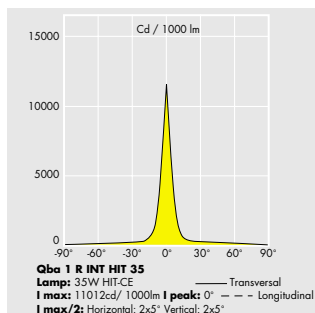
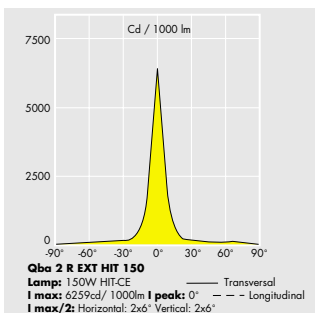
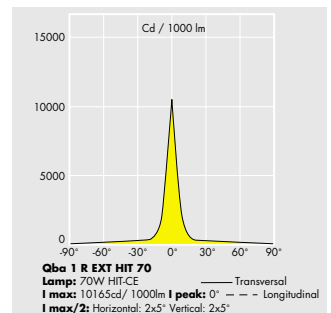
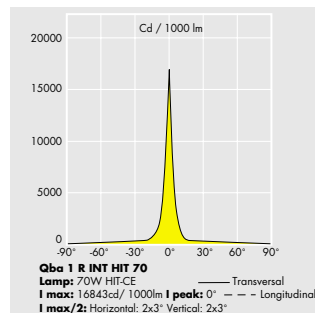
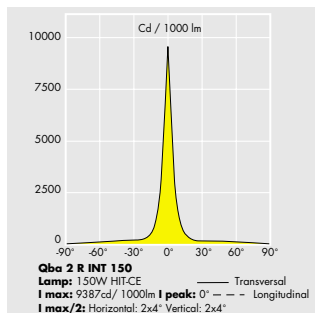
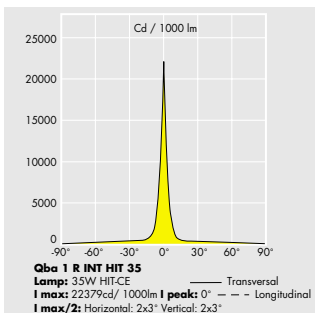
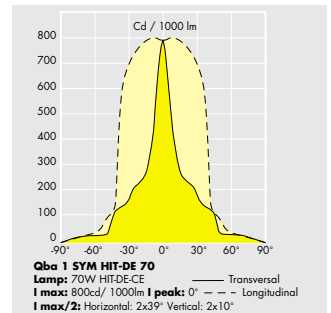
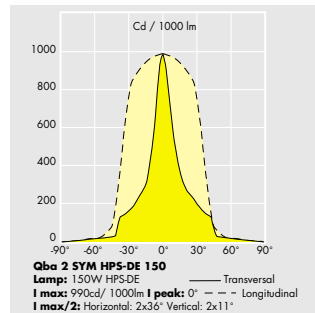
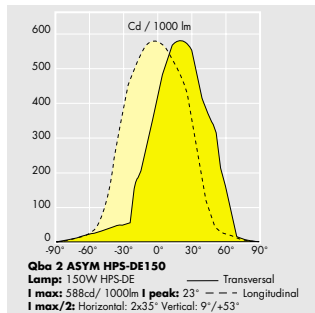
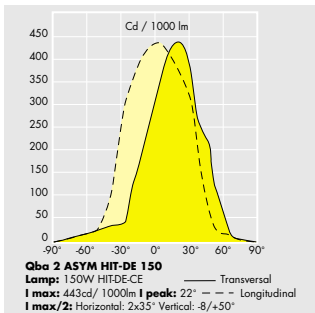
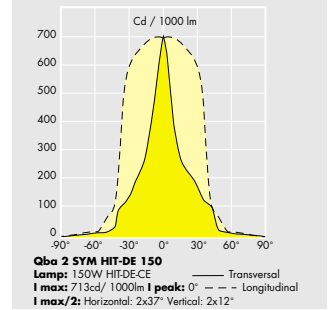
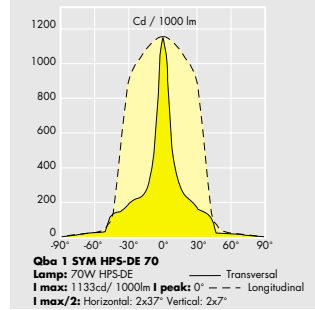
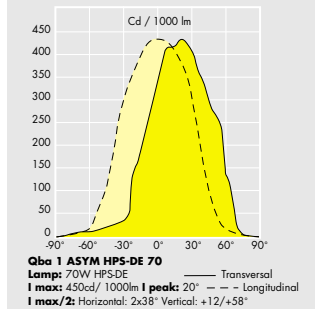
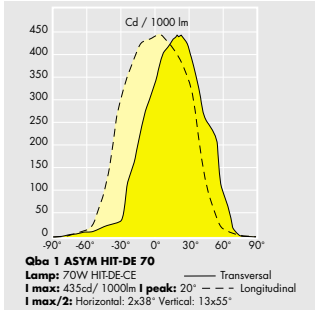

1.



2.



1. Extra knock out provided for through wiring

2. Rear access to control gear

THORN

Lighting people and places

Thorn Lighting Main Offices

Head Office

Thorn Lighting Holdings Limited
3 King George Close, Eastern Avenue West,
Romford, Essex RM7 7PP, United Kingdom
Tel: (44) 1708 766033
Fax: (44) 1708 776238
E-mail: info@thornlight.com
Website: www.thornlighting.com

Australia

Thorn Lighting Pty Limited, 13 Cooper Street,
P O Box 188, Smithfield, NSW 2164, Australia
Tel: (61) 2 9604 4300
Fax: (61) 2 9604 4588
E-mail: info@thornlight.com.au
Website: www.thornlight.com.au

Thorn DNT Airfield Lighting Pty Limited,
P O Box 548, Unit 2, 7-9 Newcastle Road, Bayswater,
Melbourne, Victoria 3153, Australia
Tel: (61) 3 9720 3233
Fax: (61) 3 9720 8233
E-mail: enquiries@thornlight.com.au
Website: www.thornairfield.com

Austria

Thorn Licht GesmbH, Erzherzog Karl-Straße 57,
Wien A-1220, Austria
Tel: (43) 1 202 66 11
Fax: (43) 1 202 66 11 12
E-mail: office@thorn.at

China

Thorn Lighting (Guangzhou) Limited,
Factory & Guangzhou Office), No 1 Yi Heng Road,
Eastern Section, GETDD, Guangzhou 510760, China
Tel: (86) 20 8224 1706
Fax: (86) 20 8224 5777
E-mail: gzhthorn@public.guangzhou.gd.cn

Thorn Lighting (Tianjin) Company Ltd, 332 Hongqi Road,
Tianjin 300190, China
Tel: (86) 22 8369 2303
Fax: (86) 22 8369 2302
E-mail: thornlj@public.tpt.tj.cn

Thorn Lighting (Guangzhou) Limited,
Shanghai Branch Office, Room 2609, Union Building,
100 Yanan Road East, Shanghai 200002, China
Tel: (86) 21 6323 0800
Fax: (86) 21 6373 1626
E-mail: thornsha@public.sta.net.cn

Thorn Lighting (Guangzhou) Limited,
Beijing Branch Office, Room 519, China World Tower I,
China World Trade Centre, Beijing 100004, China
Tel: (86) 10 6505 4601
Fax: (86) 10 6505 4603
E-mail: thornbj@public.bta.net.cn

Czech Republic

Thorn Lighting CS, spol., Jaslenska 6, Praha 6,
160 00 Czech Republic
Tel: (42) 02 2431 5252
Fax: (42) 02 3332 6313
E-mail: thorn@thornlight.cz
Website: www.thornlight.cz

Denmark

Thorn & Jakobsson, Industrivej Vest 41,
DK-6600 Vejen, Denmark
Tel: (45) 7696 3600
Fax: (45) 7696 3601
E-mail: thorn@jakobsson.dk
Website: www.thorn-jakobsson.dk

Estonia

Thorn Lighting Oy Eesti Filiaal, Laki 12-308,
10621 Tallinn, Estonia
Tel: (372) 656 3505
Fax: (372) 656 3227
E-mail: ando@thorn.ee

Finland

Thorn Lighting Oy, Airport Plaza Business Park,
Ayritie 12A, 01510 Vantaa, Finland
Tel: (358) 9 549 222
Fax: (358) 9 549 22300
E-mail: asiakaspalvelu@thornlight.fi
Website: www.thornlight.fi

France

Thorn Europhane SA, 156 Boulevard Haussmann,
Cedex 08, Paris 75379, France
Tel: (33) 1 49 53 6262
Fax: (33) 1 49 53 6240
Website: www.thorn.fr

Hong Kong

Thorn Lighting (Hong Kong) Limited, 19/F Jardine
Engineering House, 260 King's Road, Hong Kong, China
Tel: (852) 2578 4303
Fax: (852) 2887 0247
E-mail: info@thorn.com.hk
Website: www.thorn.com.hk

Thorn Lighting (HK) Ltd
Macau Branch, Room 306, 3/F Marina Gardens,
876 Avenida da Amizade, Macau, China
Tel: (853) 702 971/702 972
Fax: (853) 702 970
E-mail: thorn@macau.ctm.net
Website: www.thorn.com.hk

Hungary

Thorn Lighting Hungary Kft, West Gate Business Park,
Torokbalint, To Park H-2045, Hungary
Tel: (36) 23 501 570
Fax: (36) 23 418 120

Ireland

Thorn Lighting (Ireland) Limited,
320 Harold's Cross Road, Dublin 6W, Ireland
Tel: (353) 1 4922 877
Fax: (353) 1 4922 724
E-mail: enq.dublin@thornlight.com

Italy

Thorn Europhane Spa, Via G Di Vittorio, 2,
Cadriano di Granarolo, Bologna 40057, Italy
Tel: (39) 051 763391
Fax: (39) 051 763088
E-mail: info@thornlighting.it
Website: www.thornlighting.it

Latvia

Thorn Lighting Oy, Representative Office,
Skolas Street 21-216, Riga LV 1010, Latvia
Tel: (37) 7 332 660
Fax: (37) 7 332 660

Lithuania

Thorn Lighting Oy, Representative Office,
Kalvariju Street 1, Vilnius 2005, Lithuania
Tel: (370) 5 2 750 701
Fax: (370) 5 2 731 480

New Zealand

Thorn Lighting (NZ) Ltd, 399 Rosebank Road,
P O Box 71134, Rosebank, Auckland 7, New Zealand
Tel: (64) 9 828 7155
Fax: (64) 9 828 7591

Norway

Thorn Lighting AS, Industriveien 11, P O Box 63,
Skytta 1483, Norway
Tel: (47) 6706 2233
Fax: (47) 6706 0351
E-mail: s.kvernberg@thornlight.no

Poland

Thorn Lighting Polska Sp.z.o.o., Ul. Tarnogajska 18,
Wroclaw 50-512, Poland
Tel: (48) 71 7833 740
Fax: (48) 71 3366 029
E-mail: thorn@thornlight.pl
Website: www.thornlight.pl

Russia

Thorn Lighting Oy, Park Place, Leninskiy Prosp.,
113/1 Office D 110, Moscow 117198, Russia
Tel: (7) 095 956 59 39
Fax: (7) 095 956 59 40
E-mail: thorn@online.ru
Website: www.thornlighting.ru

Thorn Lighting Oy, Representative Office, Europa House,
1 Artilleriskaya, St Petersburg 191104, Russia
Tel: (7) 812 118 8112
Fax: (7) 812 118 8119
E-mail: thorn@thorn.ru
Website: www.thornlighting.ru

Singapore

Thorn Lighting (Singapore) Pte Ltd, 5 Kaki Bukit Crescent,
04-02 Koyotech Building, 416238 Singapore
Tel: (65) 6844 5800
Fax: (65) 6745 7707
E-mail: info@thornlight.com.sg
Website: www.thornlight.com.sg

Sweden

Thorn Lighting AB, Industrigatan, Box 305,
SE-261 23 Landskrona, Sweden
Tel: (46) 418 520 00
Fax: (46) 418 265 74
E-mail: thorn@thornlight.se
Website: www.thornlight.se

United Arab Emirates

Thorn Lighting Ltd Dubai
Al Shoala Building, Office 301,
Block E, PO Box 1200, Deira, Dubai, UAE
Tel: (971) 4 2940181
Fax: (971) 4 2948838
e-mail: tluae@emirates.net.ae

Thorn Gulf LLC
Al Shoala Building, Office 301/2,
Block E, PO Box 1200, Deira, Dubai, UAE
Tel: (971) 4 2948938
Fax: (971) 4 2948838
e-mail: thorg@emirates.net.ae

United Kingdom

Thorn Lighting Limited, 3 King George Close,
Eastern Avenue West, Romford, Essex RM7 7PP, UK
Tel: (44) 1708 766033
Fax: (44) 1708 776238
E-mail: brochures@thornlight.com
Website: www.thornlighting.co.uk

Thorn Airfield Lighting, 3 King George Close,
Eastern Avenue West, Romford, Essex RM7 7PP, UK
Tel: (44) 1708 776289
Fax: (44) 1708 776285
E-mail: airfield@thornlight.com or thornagluk@aol.com
Website: www.thornairfield.com

Export Sales

Thorn Lighting Limited, 156 Boulevard Haussmann,
Cedex 08, Paris 75379, France
Tel: (33) 1 49 53 6262
Fax: (33) 1 49 53 6240

Thorn Lighting Limited, 3 King George Close,
Eastern Avenue West, Romford, Essex RM7 7PP, UK
Tel: (44) 1708 776284
Fax: (44) 1708 741827
e-mail: international.sales@thornlight.com

www.thornlighting.com

Thorn Lighting is constantly developing and improving its products. All descriptions, illustrations, drawings and specifications in this publication present only general particulars and shall not form part of any contract. The right is reserved to change specifications without prior notification or public announcement. All goods supplied by the company are supplied subject to the company's General Conditions of Sale, a copy of which is available on request. All measurements are in millimetres and weights in kilograms unless otherwise stated.

Publication No: 257(INT) Publication date: 7/03