

AERZEN SCREW COMPRESSORS

AERZEN Screw Compressors VRa for process gas technology
Modular system single- and multi-stage for dry compression of process gases



AERZEN

COMPONENT OF YOUR PROCESS EFFICIENCY: AERZEN PROCESS GAS COMPRESSORS

AERZEN process gas compressors are installed as single or multiple stage units in chemical, petrochemical, raw material and energy producing plants and in many other production centres of the processing industry all over the world.

Standard compressors or individually designed packaged unit: AERZEN process gas screw compressor represents both.

The screw compressors are individually designed to fulfill widely differing requirements. The AERZEN process gas screw compressor uses the standard VRa-unit for the compressor block with specified ancillary accessories assembled together to form a well conceived package unit to suit each application.

Construction requirements and specifications laid down by the various industrial organizations and inspection authorities such as API or national standards will be considered according to the customer's demands.

“STATE-OF-THE-ART OF THE COMPRESSOR TECHNOLOGY: AERZEN PROCESS GAS SCREW COMPRESSOR AND ACCESSORIES”



THE DRY COMPRESSION OFFERS A LARGE RANGE OF APPLICATION POSSIBILITIES.

Within the compression chambers there is no metallic contact among both rotors as well as to the casing. Thanks to timing gear wheels resp. synchronising gears the rotors run without contact to each other. Therefore, the conveying chambers remain unlubricated and the conveyed medium will not be contaminated.



Application possibilities

Not only in the chemical industry, but also in other industry branches, AERZEN process gas screw compressors are applied in control air systems, industrial refrigeration plants, evaporation plants, mining industry and in iron and steel works. Practically all gases can be compressed, such as ammonia, argon, ethylene, acetylene, butadiene, hydrochloric gas, natural gas, flare gas, blast furnace gas, marsh gas, helium, lime-kiln, coke oven, carbon monoxide, all hydrocarbon combinations, methane, propane, propylene, flue gas, crude gas, sulphur dioxide, nitrogen monoxide, nitrogen, styrene, vinylchloride and hydrogen gas.

Limits of application

The limits of application for the screw compressors are given by the pressure and temperature ranges and by the admissible speed of the machines.

Normally the screw compressors can be mechanically loaded with pressure differences up to 12 bar.

Pressure differences up to 25 bar apply for special cases of requirement and application. The maximum admissible compressor ratio for one screw compressor stage that will not cause the final compression temperature to rise above the permitted value of 250 °C will to a very large extent depend on the specific heat ratio of the gas to be compressed, e.g. for $c = 1,4$ max. compression ratio approx. 4,5 or for $c = 1,2$ max. compression ratio approx. 10, pressure ratio: $\pi = \frac{p_2}{p_1}$

With multistage design final pressures to a max. of 53 bar can be achieved. For vacuum applications an absolute pressure of 0,9 bar can be reached. The process gas screw compressors are equipped with intermediate cooling.

The compressor speed varies between approx. 2.000 and 20.000 rpm depending on the machine size - whereby the peripheral speed of the rotor is the specific factor for the speed of the main rotor, which ranges from 50 to 130 m/s, up to max. 150 m/s, for gases with a low specific weight.

Technical layout

The compressor housing of the smaller series is vertically split on the suction side, the cylinder is designed as so-called pot-type cylinder. The series of the larger size is in addition split horizontally for easy assembly.

Rotors and shafts are machined out of drop-forged steel or stainless steel. In principle the process gas machines have the direction of flow from the top to the bottom, thus fulfilling an essential factor for the required liquid injection, which is necessary in many fields of application where the gases are contaminated or polymerized. The sealing area is equipped with connections for buffer gas and relief for sealing media and inert gas.

Rotor profile

The AERZEN process gas screw compressors have an asymmetrical rotor profile. The combination 4 + 6 means that the main rotor has 4 teeth and the secondary rotor 6.

Due to this combination the diameter of the core is relatively thick, thus allowing large differential pressures combined with high volumetric efficiencies.

Bearing

Screw compressors with slide bearings are suited in particular for high pressure loads and a high rotor speed.

For radial loads unsplit slide bearings are used. The axial bearings are of spherical self-adjusting type with multi-segments to adjust to rotor deflection. The negative axial bearing is loaded only during the start-up and rundown phase of the machine.



secondary rotor

main rotor

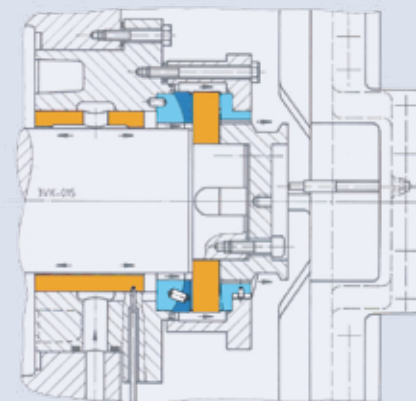

Oil system, oil lubrication

Usually separate oil systems are applied. According to present operating conditions vented or pressurized oil reservoirs (up to 16 bar) can be used for this system with retention times of 2 to 8 min.

Electric oil heating systems with level controller or steam heating can be installed in the oil reservoir. Mechanical oil pumps driven by gearbox can be used as well as oil pumps driven by a motor or a turbine. Double oil coolers and twin oil filters take care of the re-cooling and filtering of the lube oil.

The generously designed oil systems ensure an efficient lubrication by pressurized oil on the radial and axial bearings of both compressor and turbo gearbox and they furthermore guarantee an optimum functioning of the oil-lubricated and oil-cooled mechanical seals.



Soda Sanayii, Mersin (Türkei), Verdichtung von Kalkofengas VRO 836 L, Ansaugvolumenstrom von 45.000 m³/h, Verdichtung von 0,85 auf 3,5 bar (abs.), wassergesperrte Kohlelabyrinthdichtung

COMPETENCE IN DETAIL: THE SEALING VARIANTS.

In order to achieve an exact separation between the gas side and the lube oil area we use a number of sealing systems which are described below. The process gas machines can be equipped with the following special sealing systems according to the feature of the gas to be compressed.

At the conveying chamber:

- a) carbon labyrinth (dry)
- b) carbon labyrinth (water-purged)
- c) single-acting oil-sealed mechanical seal with carbon rings arranged upstream
- d) double-acting mechanical seals
- e) mechanical seal, tandem arrangement, gas-sealed

At the drive shaft:

- a) labyrinth sealing
- b) double-acting mechanical seal

Sealing of conveying room:

a) carbon labyrinth The carbon labyrinth seals with discharge and seal gas connections are used for neutral, clean gases in cases where leakage gas, even in connection with seal gas may enter into the oil rooms and into the atmosphere or into the residual gas pipings. The gas pressure is relieved across the carbon labyrinth rings where the carbon rings are floating in the leaking gas.

Material: steel or stainless steel / graphite with armoured ring.

b) carbon labyrinth, water-sealed

In case of the water-sealed floating ring sealing an amount of seal water reaches the compressor room; the larger amount is led to the outside, it is fed back to the seal water system. Besides the sealing effect this seal water in the cylinder at the same time also has the function of cooling and rinsing the conveyed gas.

This amount of water can be fed back and used once again after necessary treatment. In this case leakage gas cannot escape to the outside. In addition an air trap between the water and oil sealing prevents the seal water from penetrating in the oil system.

Material: steel or stainless steel / impregnated graphite with armoured ring.

c) single-acting oil-sealed mechanical seal with carbon rings arranged upstream

The combined floating mechanical sealings combine the advantages of both systems. The installation is used particularly for machines with high differential pressures.

Material: stainless steel / graphite – tungsten carbide

d) double-acting mechanical seals, gas-, oil- or water-sealed

Double-acting gas-sealed mechanical seals are applied in case of final pressures with high compression. The sealing can be effected by means of sealed nitrogen but also by means of self-medium.

Double-acting mechanical seals, water- and oil-sealed guarantee no leakage gas part and hardly any losses of seal liquid.

e) mechanical seal, tandem arrangement, gas-sealed

Mechanical seals in tandem arrangement are used in cases where it is not allowed to have a leakage of process gas to the atmosphere or a leakage of seal gas to the product.

Sealing of drive shaft:

2a) labyrinth sealing

2b) double-acting mechanical seals

The drive shafts of the screw compressor and the turbo gearbox have in case of depressurized oil systems labyrinth seals and in case of pressurized oil systems double-acting mechanical seals which are connected to the oil pressure piping.

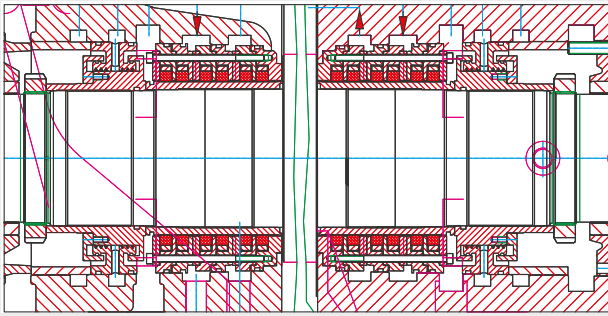

a)

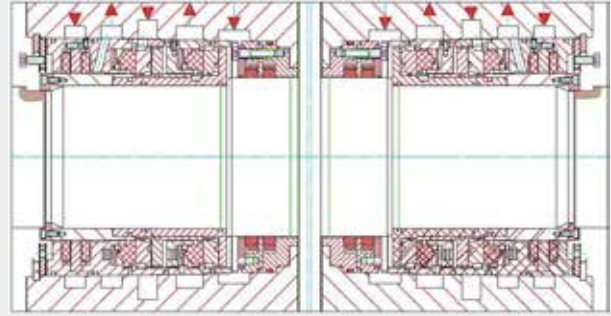

e)

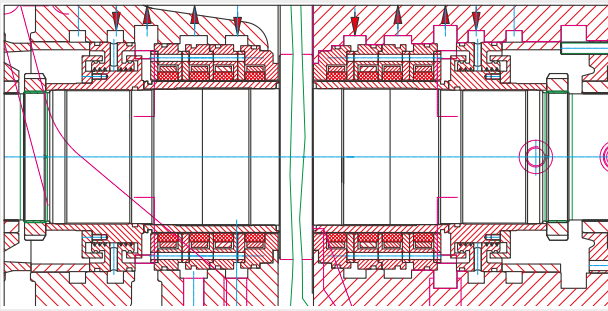

b)

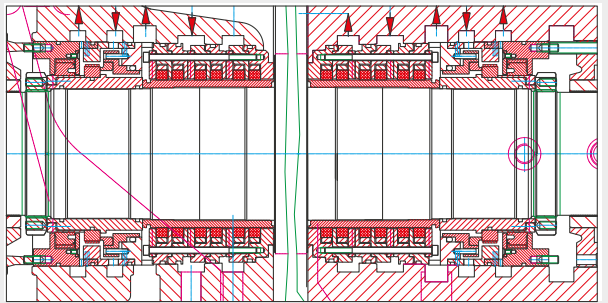

c)

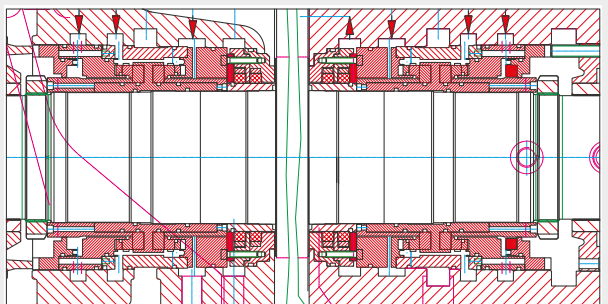

d)

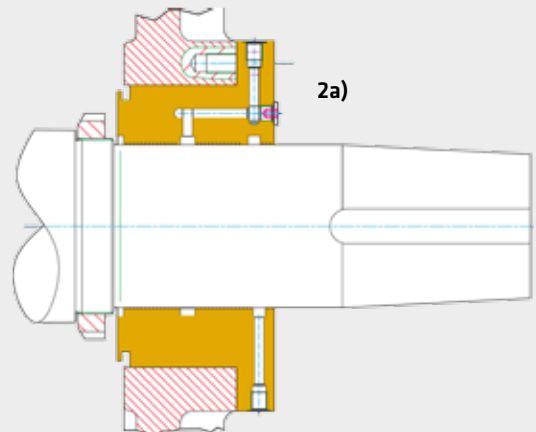

2a)

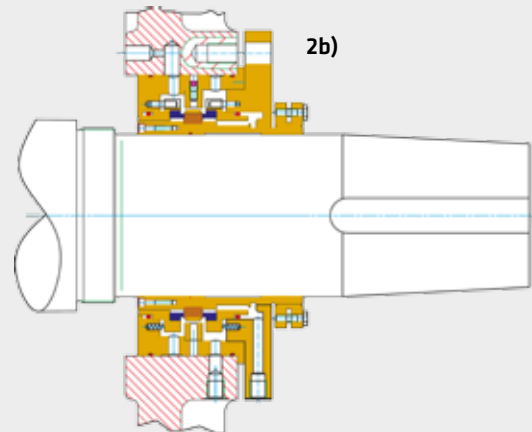

2b)

CERTIFIED SAFETY – AERZEN QUALITY ASSURANCE.

Prior to delivery a test run of the compressor stage is carried out lasting for several hours. The performance testing is carried out as single stage testing, drive by a galvanized test bench motor. The inspection and test certificates will be supplied on request.

Drive

The unit is designed to be driven by electric motor, steam or gas turbine. Drive is made via spur gear or direct coupling.

Gears, timing gears

Close-ratio, standardized step-up gears enable almost any desired flow volume to be obtained. The gears used are designed as flanges or as a separately coupled turbo gear. For twoor multistage units double turbo gears having one drive shaft and two output shafts are used.

The timing gears prevent the rotor teeth of main and secondary rotor from touching each other. The gear flank clearance must be set to a lower value than that of the rotors.

Instrumentation, automatic control

The monitoring and protection of the operating data is carried out via pressure transmitter and resistance thermometer. The measuring value indication is displayed in the control panel. Regarding the control it can be selected among various well-known manufacturers.

Materials

Depending on each individual case of need, appropriate materials are used.

Housing: nodular cast iron, steel casting, stainless steel
Rotors: carbon steel, stainless steel
Gear wheels: case-hardened steel
Sealings: see sealings

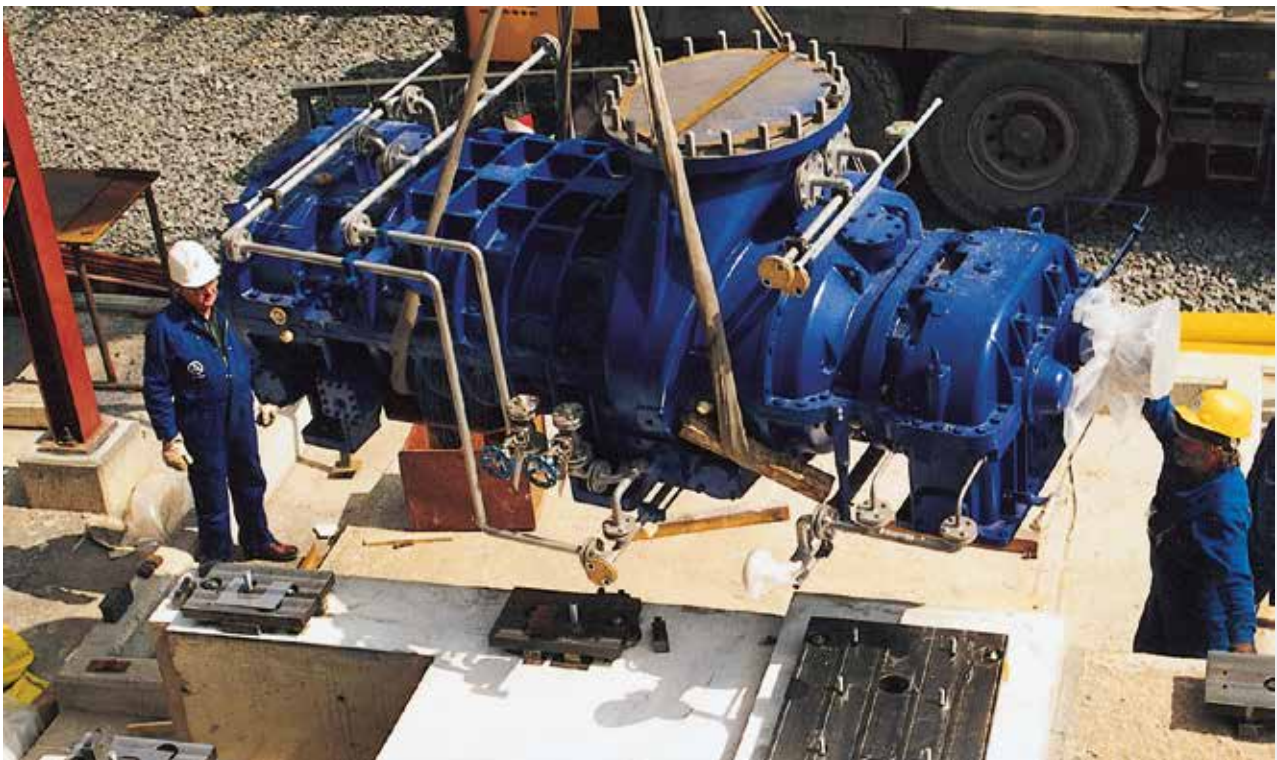

Kaucuk A.S., Kralupy (Czech Republic) Assembly of a process gas compressor VRa 736 L

Cooling

The cooling of the compressor housing is carried out by convection, therefore a cooling water connection is not necessary.

Regulation

In case of a drive with constant speed, e.g. electric motor, the volume should be regulated as follows:

intermittent operation with bypass incl. overflow controller
resp. interstage pressure control on multiple stage installations.
If the volume flow is continuously variable it is possible to operate within a limited speed range (e.g. variable speed motor, turbine).

Smooth running, silencing

The machines are not equipped with any reciprocating masses. All moving parts rotate and are dynamically balanced, so that no forces of gravity may arise.

The sonic energy entering into the pipes is reduced to a large extent by specially designed absorption- resp. pulsation silencers as well as compensators - depending on each particular demand. Where special requirements on silencing are made it is possible to place the entire unit under an acoustic hood. Design and size according to individual demands.

Special designs

Besides the use of special materials it is of course possible to make any modification required on the unit itself or even special designs, e.g.: For neutral gases with elevated intake pressure in completely enclosed design.

The gear housing and the oil system can be loaded with pressures up to $p_e = 16$ bar. For vacuum operation special sealing arrangements are necessary.

Design guidelines

- DIN / EURO - standards
- NACE
- AD - regulations
- TEMA - standard
- ASME - standard
- API

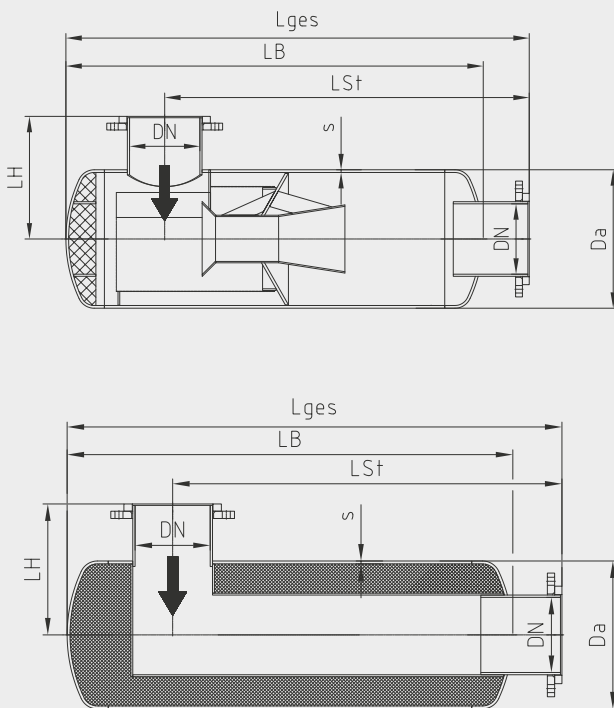

*Soda Sanayii, Mersin (Turkey), compression of coke oven gas
VRO 836 L, intake volume flow of 45.000 m³/h,
compression of 0,85 to 3,5 bar (abs.),
water-purged carbon labyrinth sealing*

COMPRESSOR POWER - STRAIGHT TO THE POINT. THE PERFORMANCE TABLES.

Performance data - single-stage design

Compressor size Type	Volume flow ca. [m ³ /h]	Overpressure up to p _e bar [approx. value]	Discharge pressure max. bar abs. [approx. value]
VRa 137 L	950 - 2200	3,5*	16*
VRa 337 L	2500 - 6000		16*
VRa 437 L	3800 - 9000		16*
VRa 537 L	6150 - 15600		10
VRa 736 L	14000 - 27000		10
VRa136 M	800 - 1600	6	25
VRa 336 M	2000 - 3800		25
VRa 436 M	3300 - 6600		25
VRa 536 M	5000 - 10000		22
VRa 736 M	12500 - 24000		12
VRa 836 M	18900 - 49000		7
VRa 936 M	29500 - 75000		7
VRa 1037 M	46000 - 120000		7
VRa 136 S	550 - 1100	12	45
VRa 236 S	800 - 1900		45
VRa 336 S	1400 - 3200		40
VRa 436 S	2150 - 5200		34
VRa 536 S	3500 - 8800		19
VRa 736 S	8500 - 15000		14
VRa 236 H	750 - 1650	25	53
VRa 336 H	1320 - 2800		53

Measures, weights and performance data are for information only and without responsibility!

The above data are approximate values for the compression of all industrial gases.

Intake conditions: p₁ = 1 bar; t₁ = 20 °C.

Performance data for higher compression final pressures or vacuum pressures on special request.

*Higher differential pressures and final pressures on request.

Dimensions and connection dimensions – single-stage unit (example)

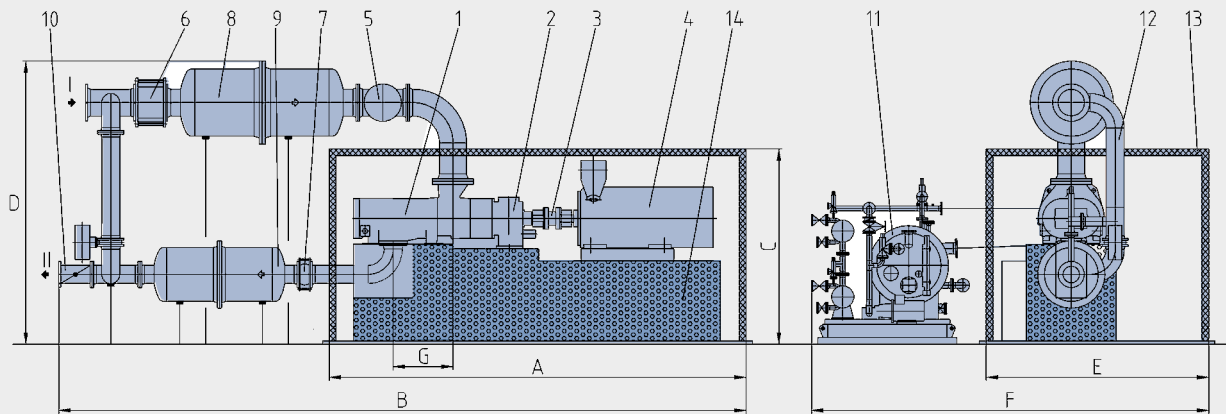

- 1. screw compressor
- 2. gearbox
- 3. coupling
- 4. drive motor
- 5. starting strainer
- 6. lateral compensator SS
- 7. lateral compensator DS
- 8. intake silencer
- 9. discharge silencer
- 10. non-return valve

- 11. oil unit
- 12. bypass
- 13. acoustic hood
- 14. concrete foundation
- 15. base frame

I gas inlet
II gas outlet

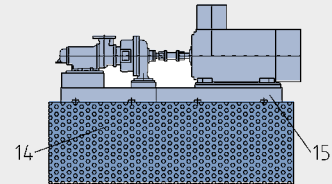

- 14 installation on sectional steel frame
- 15 Integrated oil system in the base frame

Measures, weights and performance data are for information only and without responsibility!

Compressor Type	A	B	C	D	E	F	G	DN SS	DN DS	Weight [kg]
VRa 136 M/S	4400	6800	2600	3300	2500	4800	231	150	100	4000
VRa 137 L	4500	7000	2600	3300	2500	4800	336	150	100	4500
VRa 236 S/H	4700	7200	2800	3300	2800	5200	248	200	150	5000
VRa 336 M/S/H	4900	7500	3100	4000	3000	5800	310	250	150	6000
VRa 337 L	5100	7700	3100	4000	3000	5800	497	250	150	7500
VRa 436 M/S	5600	9800	3600	4200	3400	6200	430	300	200	10000
VRa 437 L	5800	10000	3600	4200	3400	6200	642	300	200	11500
VRa 536 M/S	6000	10200	3800	4400	4400	6800	635	400	250	16000
VRa 537 L	6300	10500	3800	4400	4400	6800	905	400	250	18500
VRa 736 M/S	7400	13600	4400	5200	5000	7000	830	600	400	26000
VRa 736 L	7800	14000	4400	5200	5000	7000	1236	600	400	27500
VRa 836 M	8400	16000	4800	6000	4000	7500	1352	800	500	42000
VRa 936 M	10000	18000	5200	7000	5300	8400	1660	900	600	55000
VRa 1037 M	12000	22000	6500	8000	7300	11000	2346	1400	1200	75000

multi-stage on request!

Flow scheme VRa - (carbon labyrinth, dry)

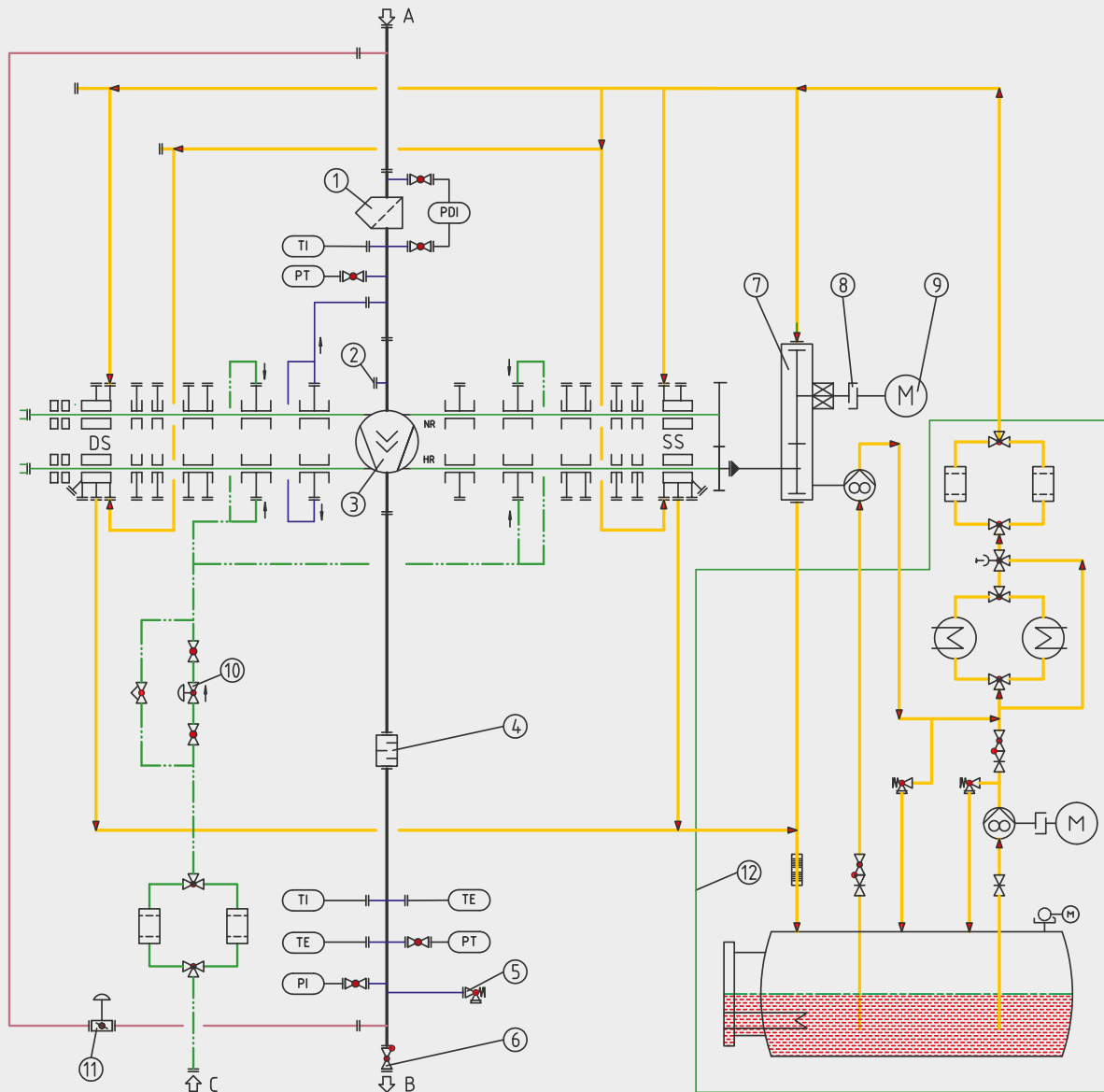

- 1. starting strainer
- 2. water injection
- 3. screw compressor
- 4. discharge silencer
- 5. safety relief valve
- 6. non-return valve

- 7. gearbox
- 8. coupling
- 9. drive motor
- 10. seal gas controller
- 11. bypass valve
- 12. oil unit

- A gas inlet
- B gas outlet
- C seal gas connections

Flow scheme VRa - (carbon labyrinth, water-sealed)

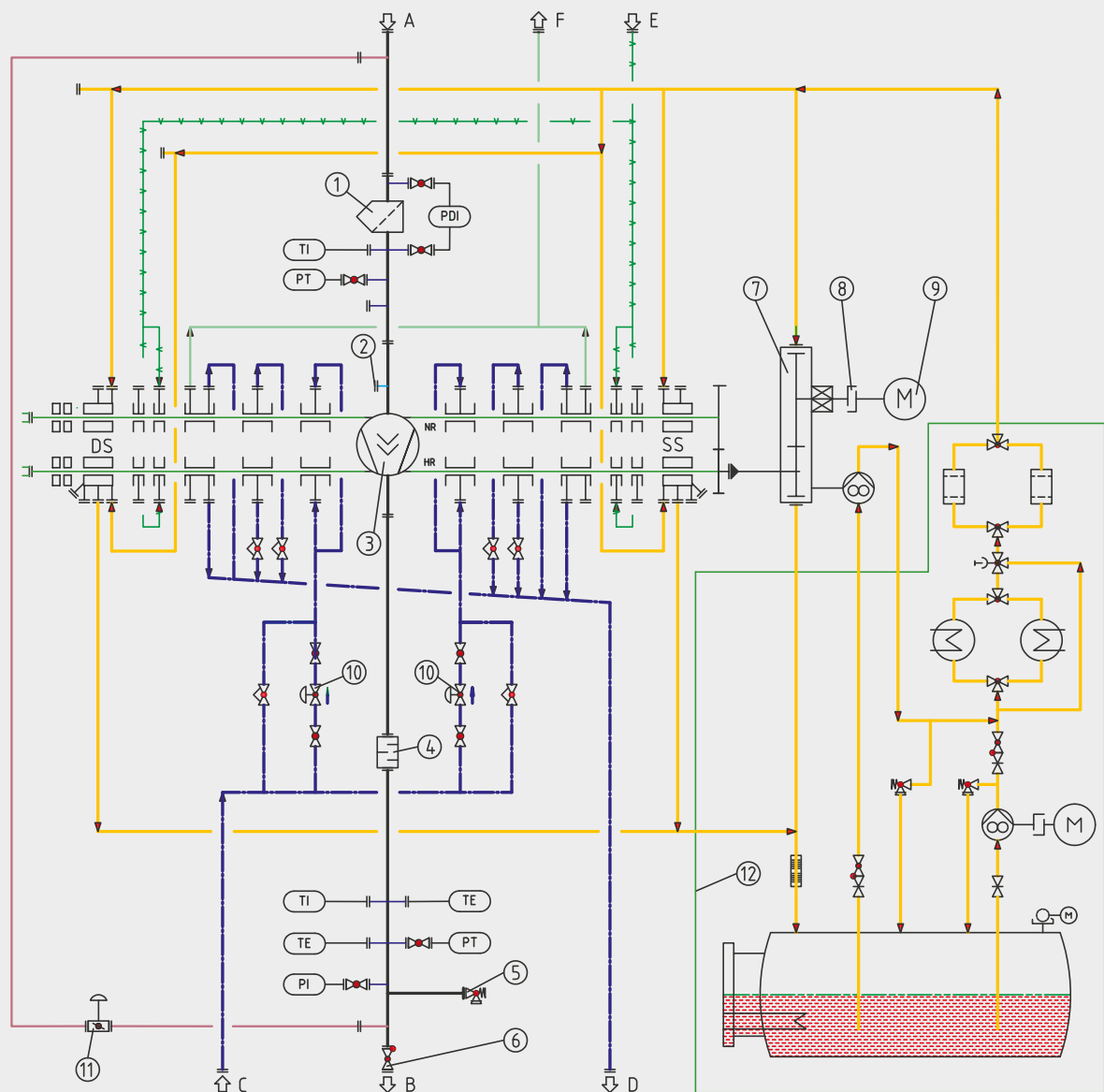

- 1. starting strainer
- 2. water injection
- 3. screw compressor
- 4. discharge silencer
- 5. safety relief valve
- 6. non-return valve

- 7. gearbox
- 8. coupling
- 9. drive motor
- 10. seal gas controller
- 11. bypass valve
- 12. oil unit

- A gas inlet
- B gas outlet
- C seal water inlet
- D seal water return
- E seal air inlet
- F aeration

Flow scheme VRa - (single-acting oil-sealed mechanical seal with carbon rings switched in advance)

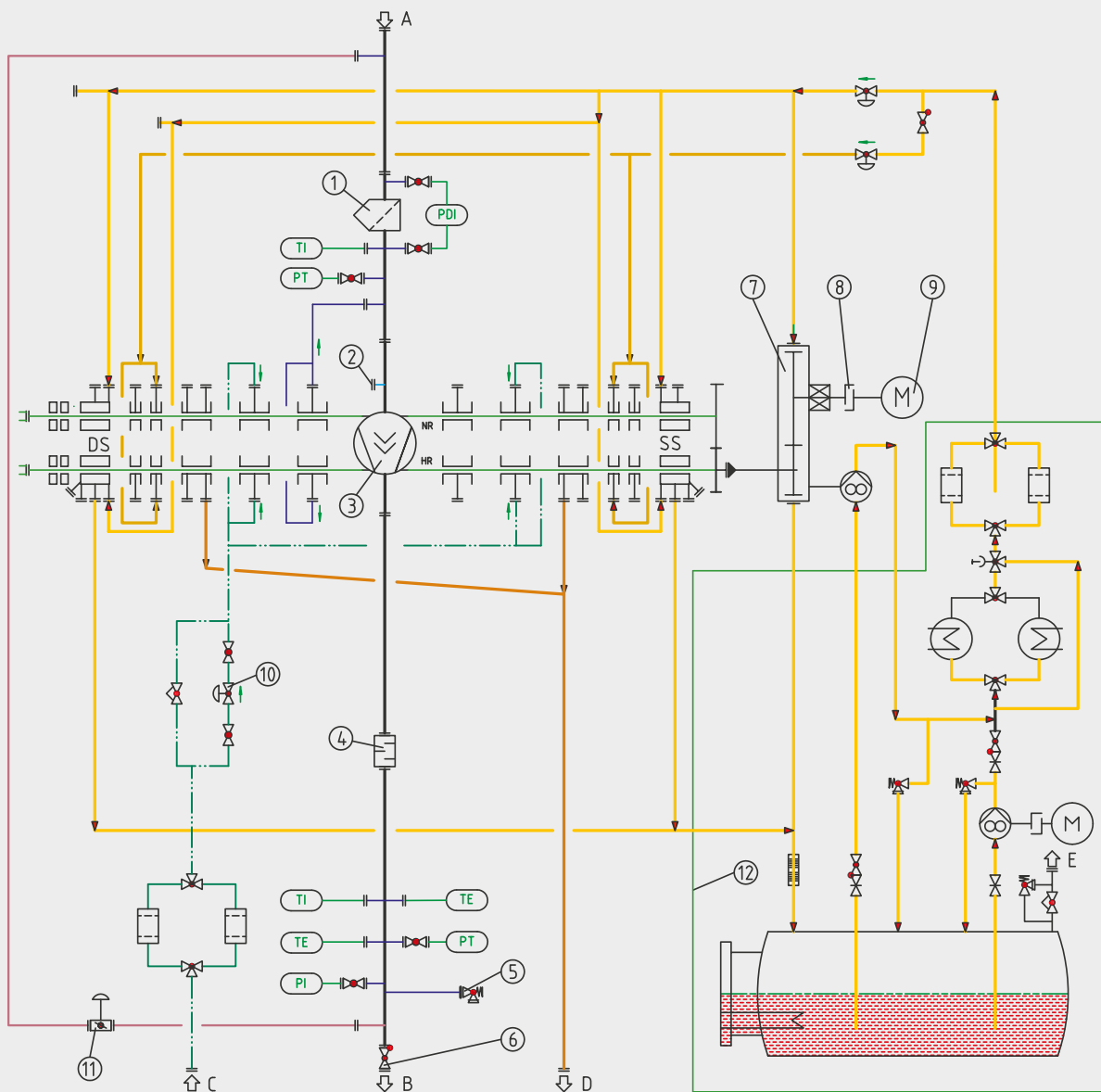

- 1. starting strainer
- 2. water injection
- 3. screw compressor
- 4. discharge silencer
- 5. safety relief valve
- 6. non-return valve

- 7. gearbox
- 8. coupling
- 9. drive motor
- 10. seal gas controller
- 11. bypass valve
- 12. oil unit

- A gas inlet
- B gas outlet
- C seal gas connection
- D leakage mechanical seal
- E degassing oil reservoir

Flow scheme VRa - (double-acting mechanical seals, gas-, oil- or water-sealed)

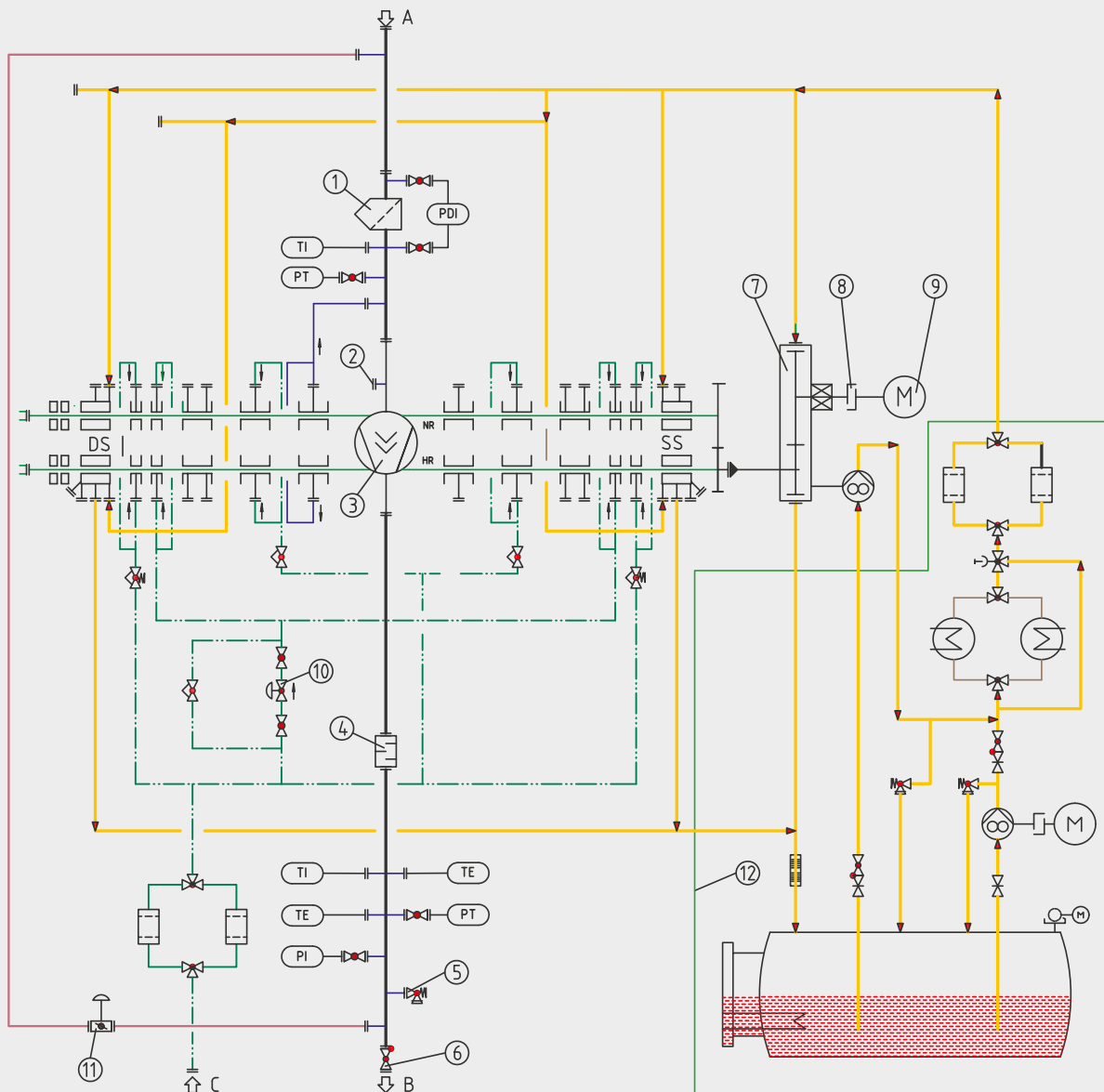

- 1. starting strainer
- 2. water injection
- 3. screw compressor
- 4. discharge silencer
- 5. safety relief valve
- 6. non-return valve

- 7. gearbox
- 8. coupling
- 9. drive motor
- 10. seal gas controller
- 11. bypass valve
- 12. oil unit

- A gas inlet
- B gas outlet
- C seal gas connection

Flow scheme VRa - (mechanical seal, tandem arrangement, gas-sealed)

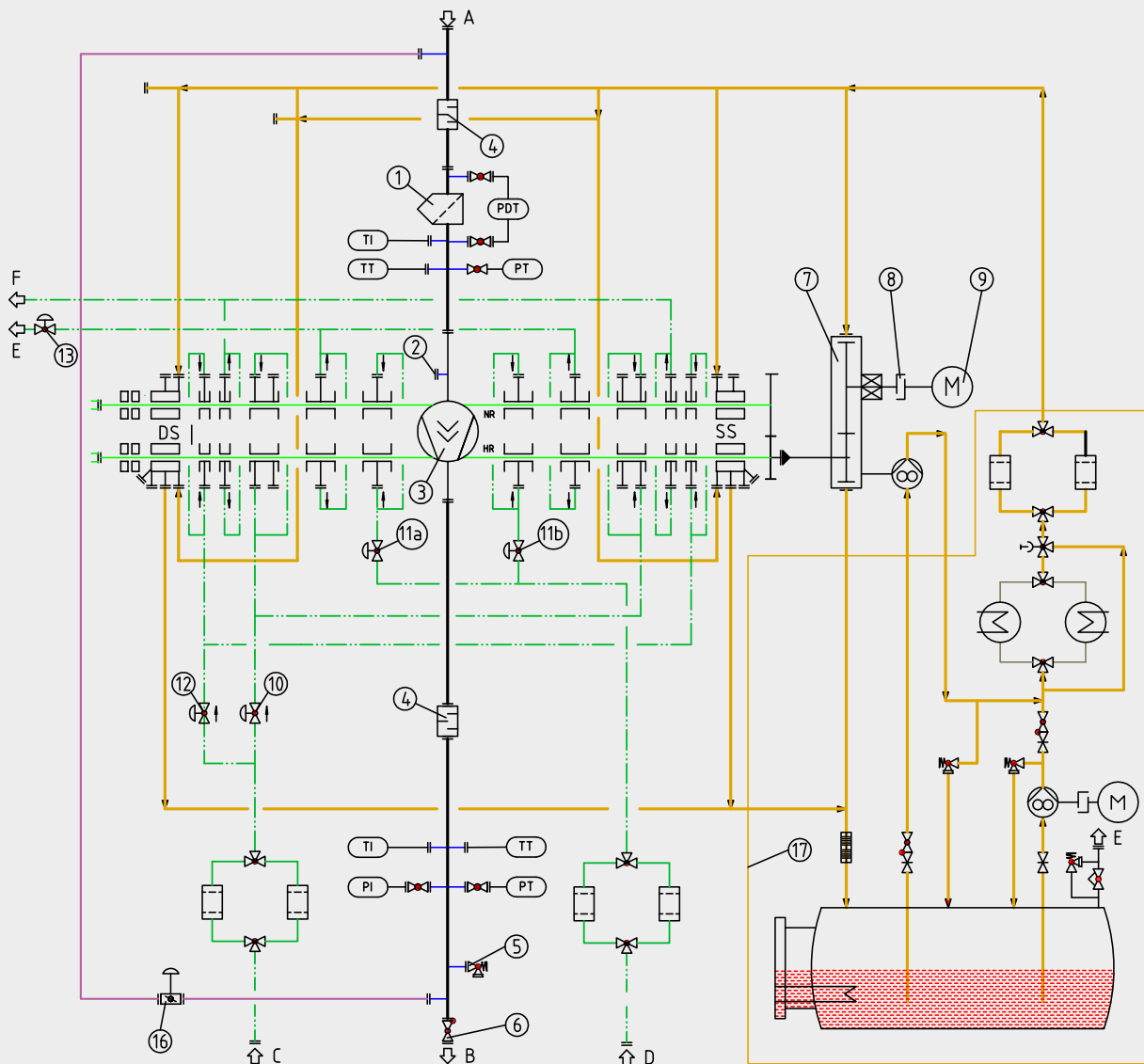

- 1. starting strainer
- 2. water injection
- 3. screw compressor
- 4. discharge silencer
- 5. safety relief valve
- 6. non-return valve
- 7. gear box
- 8. coupling

- 9. drive motor
- 10. seal gas regulator
- 11. flushing gas regulator
- 12. separating gas regulator
- 13. flare counter pressure regulator
- 16. bypass valve
- 17. oil unit

- A gas inlet
- B gas outlet
- C seal / separating gas connection
- D flushing gas connection
- E relief flare
- F deaeration atmosphere / flare
- H degasification oil tank

Aerzener Maschinenfabrik GmbH
 Reherweg 28 - 31855 Aerzen / Germany
 Telephone: +49 5154 81-0 - Fax: +49 5154 81-9191
 info@aerzener.de - www.aerzen.com



AERZEN
 EXPECT PERFORMANCE