

**SULZER**

Sulzer Pumps

## ABS Submersible Mixer XRW

The right motor  
solution to match  
the mixing task



The Heart of Your Process

abs

# The World-Class Range of Submersible Mixers

Sulzer Pumps first launched the ABS submersible mixer XRW as an innovative medium-speed mixer concept in 2010. After widespread success, it is now available as a complete mixer range with motor technologies adapted to varying applications.

The ABS submersible mixer XRW was introduced as the first submersible mixer with a permanent magnet motor. But its defining feature was not the motor itself. It was the mixer's unique balance of energy efficiency and economy.

Sulzer Pumps has kept this balance in focus when expanding the ABS submersible mixer XRW into a full product range. To maintain it at various speeds, three distinct motor configurations have been used:

- **High speeds**  
Premium-efficiency IE3 squirrel-cage motor
- **Medium speeds**  
Premium-efficiency permanent-magnet motor (IE3-equivalent)
- **Medium-low speeds**  
Premium-efficiency IE3 motor with gearbox

Choosing the right configuration for the job has substantial advantages over applying the same construction to every need.

## The Most Appropriate Motor Technology

The use of multiple motor configurations gives the ABS submersible mixer XRW the best balance of equipment price, motor efficiency and long-term operating costs. No single motor technology can achieve this.

When you choose the ABS submersible mixer XRW, you therefore choose the market's best energy performance. But you also get the best life-cycle economy, from initial purchase to ongoing operation.

## Minimal Energy Consumption

The use of premium-efficiency motor technologies, together with optimized and proven propeller designs, gives the ABS submersible mixer XRW the lowest energy consumption for each mixing speed. You gain a total efficiency improvement of up to 35% compared with other mixer designs, which reduces your power consumption and carbon footprint.

## Cost-Effective Installation and Maintenance

The combination of compact design and considerably reduced weight allows easy mixer installation and removal. Additional maintenance advantages are offered by the medium-speed models of the ABS submersible mixer XRW (see right).

## Superior Reliability

The reliability of the ABS submersible mixer XRW is just as high as its efficiency. Contributing factors include:

- Optimized mechanical seal
- Enhanced design of the solids deflection ring
- Strong new bearings with a life of 100,000 hours
- High overload capacity (medium-speed models)
- Robust gearbox with fatigue-strength planetary gears (medium-low-speed models)

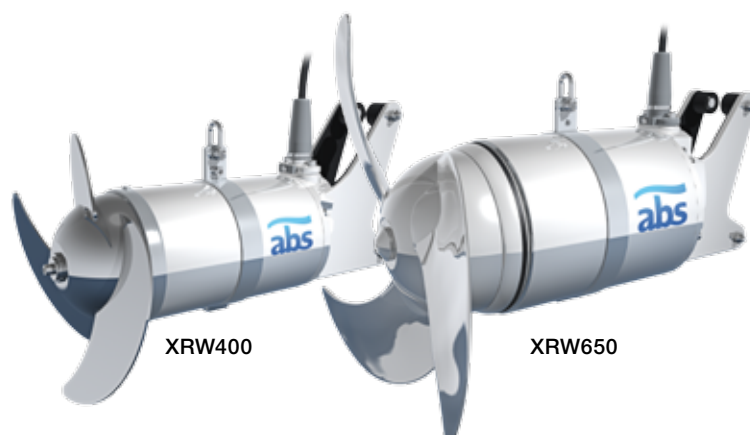

Medium-speed models of the ABS submersible mixer XRW come in a CR version manufactured entirely from stainless steel. All other models are available in both the CR version and a blue EC version, which has a mixer body of epoxy-painted cast iron.



## Additional Benefits With Permanent Magnets

Medium-speed models of the ABS submersible mixer XRW offer several additional advantages. These derive from the use of permanent-magnet motors and include:

- **Greater process control**  
A variable-speed drive allows process optimization and further reductions in energy consumption – beyond the savings obtained through the high-efficiency equipment design.
- **Fewer mixers for wide application**  
The use of a permanent-magnet motor and a variable-speed drive allows a limited number of basic mixer sizes to cover a wide range of applications. Uptime can thus be ensured with a reduced stock of spare equipment and parts.
- **Even more cost-effective maintenance**  
An ABS EffeX Exchange Program for permanent-magnet motors, together with the smaller number of basic mixer sizes, gives you cost-effective maintenance without the need for specialist equipment.

### Part of the ABS EffeX Revolution

The ABS EffeX revolution is an ongoing effort from Sulzer Pumps to push the boundaries of wastewater technology, especially in the area of energy efficiency. Encompassing the whole chain from design to manufacturing, it has resulted in the most innovative and resource-conserving solutions on the market.

The revolution began in 2009 with the launch of the ABS submersible sewage pump XFP. Since then, it has expanded to comprise a complete range of world-class wastewater products. Their energy savings, reduced carbon footprint and high reliability contribute to efficient processes and satisfy the growing demands placed on the wastewater industry.

The **ABS EffeX** Revolution continues

# The Most Appropriate Motor Technology

Two factors decide the configuration of the ABS submersible mixer XRW. The first is the required intensity of the mixing and flow. The second is how premium efficiency can be achieved most economically. Three motor configurations provide the best possible balance.

## For High Speeds

In more intense applications with high speeds, the most economical way to premium efficiency is a squirrel-cage induction motor of IE3 standard. This configuration is direct-driven, which means the propeller is mounted on the motor shaft without any gearbox.

## For Medium Speeds

In the medium-speed range, an IE3-equivalent permanent-magnet motor provides the lowest possible energy consumption and best lifetime economy. Variable-speed control allows precise optimization of your process, as well as a reduction in spare parts, since one mixer size covers a wider range of speeds.



Sulzer Pumps has an extensive knowledge of permanent-magnet motors, derived from their development and inclusion in our range of ABS turbo-compressors HST. You can learn more about permanent-magnet motors and their advantages by folding out the adjacent page.

## For Medium-Low Speeds

In applications involving medium-low speeds, a squirrel-cage induction motor of IE3 standard is used with a speed reducer. While a permanent-magnet motor would be effective here as well, a more traditional solution provides better economy at these speeds.

The speed reducer is a robust single-stage planetary gearbox with high efficiency and a very long operating life. Its fatigue-strength planetary gears allow numerous reduction ratios, which makes the drive both compact and lightweight.

The gearbox has the same strong design as that of the slow-running ABS flow booster XSB, which is part of the ABS EffeX range and an ideal choice for low-speed mixing.



## High Speeds



Premium-efficiency IE3 squirrel-cage induction motor



XRW210  
(4-pole motor)



XRW300  
(6-pole motor)

## Medium Speeds



Permanent-magnet motor  
(IE3-equivalent)



XRW400



XRW650

## Medium-Low Speeds

Premium-efficiency IE3 squirrel-cage induction motor  
Single-stage planetary gearbox

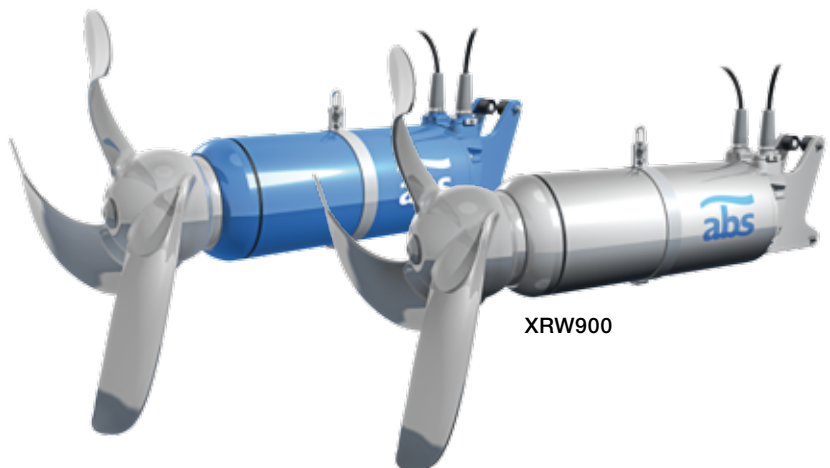

XRW900

*Fold out for a detailed look at the mixer construction and the advantages of permanent-magnet motors.*

# An Overview of Permanent-Magnet Motors

Permanent-magnet motors provide unique advantages in medium-speed models of the ABS submersible mixer XRW. Sulzer Pumps has an extensive knowledge of their use, derived from their development and inclusion in our range of ABS turbocompressors HST.

## A Growing Trend

Permanent-magnet motors have been commercially available for about 20 years, but lower component prices and better technology have recently made them more attractive. For example, there has been a continuous reduction in the cost of the variable-frequency drives (VFD) used to run them.

In addition, their growth is being driven by the demand for energy savings. Permanent magnet motors require less electrical power, and they provide higher motor efficiency within a wide range of speeds.

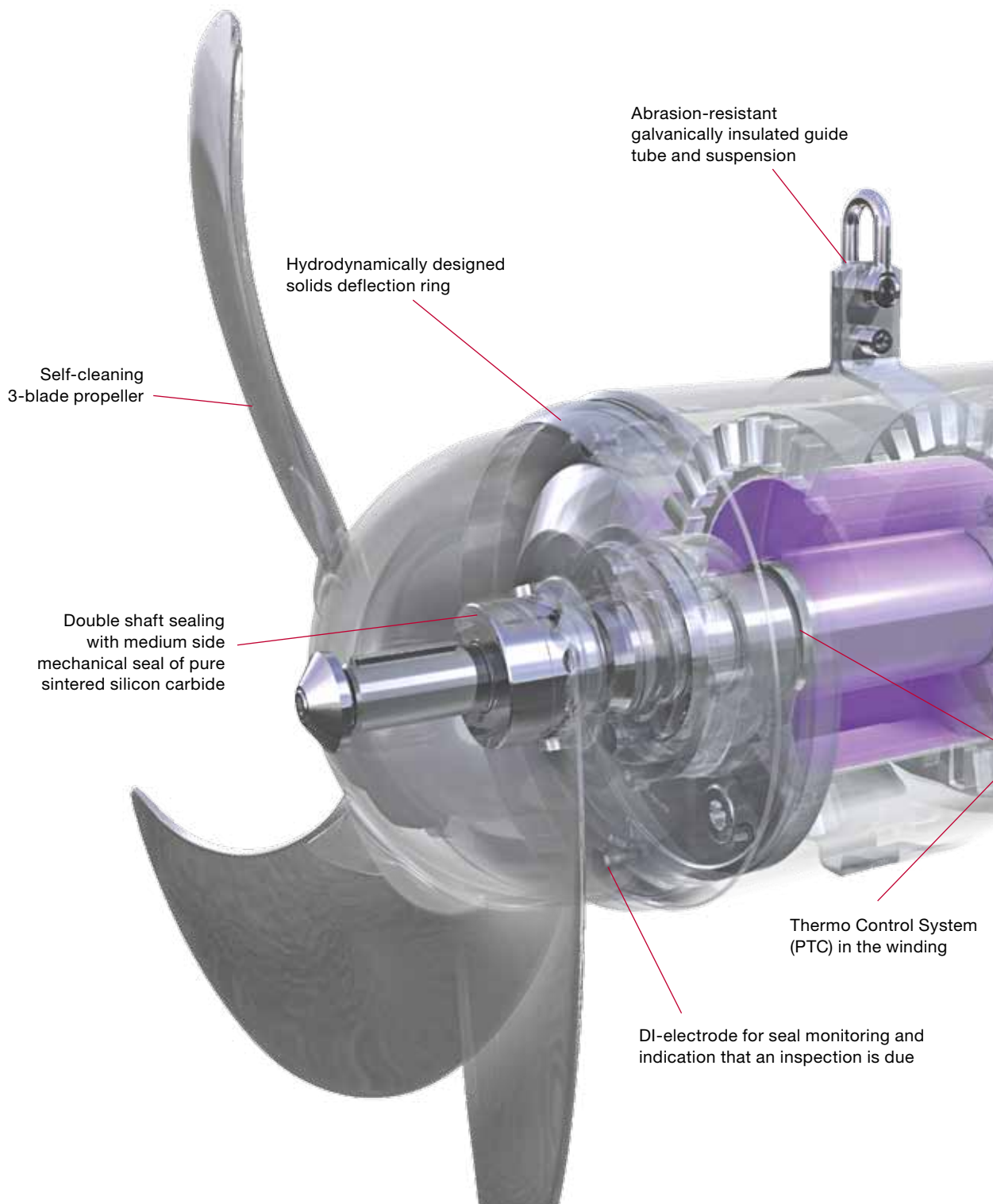

### Sensorless Control

With permanent-magnet motors, a controller involving an algorithm is used to monitor the position of the rotor. Some designs use Hall effect sensors or an encoder to measure the rotor position directly. Instead, the ABS submersible mixer XRW uses measurements of the reacting electromotive force (EMF) in the windings of the stator magnets to determine the rotor position. Since no Hall sensors are used, this type of design is often called sensorless control.

### Extensive Benefits

Compared with the conventional use of inverter-controlled (VFD) motors, permanent-magnet motors offer many advantages. And although these motors have a higher initial cost, it is quickly recovered through their greater efficiency and significant reduction of energy consumption.

The many benefits of permanent-magnet motors include:

- Higher motor efficiency within a wide speed range
- Greater reliability and longer lifetime
- Lower operating temperature
- Compact design and less weight
- Less electrical power to drive the motor
- Flexible system operation

These benefits can make a substantial difference in the performance and economy of numerous applications.

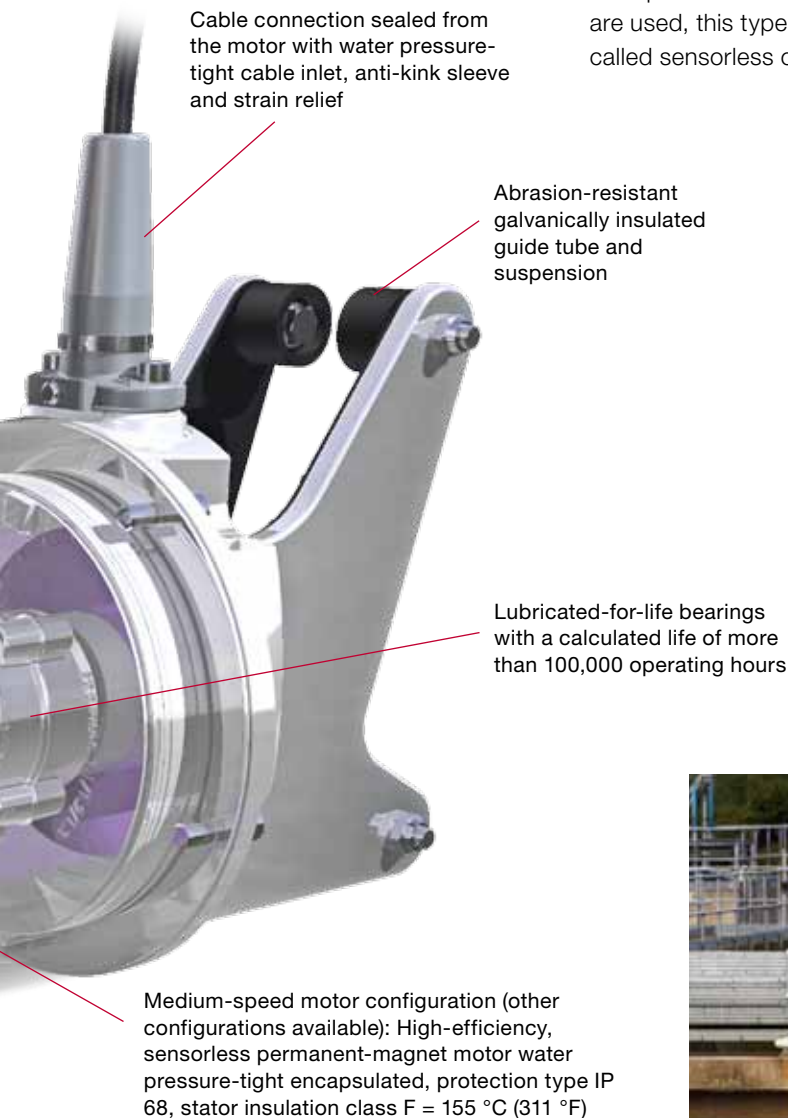

# Delivering World-Class Performance

The ABS submersible mixer XRW is part of a complete, world-class product range from Sulzer Pumps. Gathered under the ABS EffeX name, the range embodies our unique drive to define the leading edge of wastewater technology.

## Leading Wastewater Innovation

Sulzer Pumps is a wastewater specialist with outstanding customer relations and extensive application expertise. As the only supplier on the market with a complete range of premium-efficiency wastewater equipment, we lead the way in solving the challenges faced by municipal, industrial, commercial, and domestic end-users.

Our ABS product brand is synonymous with innovation and well-proven solutions for wastewater collection and treatment. Nothing makes this clearer than the ABS EffeX range.

## The ABS EffeX Revolution

The ABS EffeX range targets legislative demands to reduce energy use and carbon footprint. Yet it also meets fast-changing needs within wastewater collection and treatment. In addition to using premium-efficiency motors, we address the causes of blockage and the effects of reduced water consumption and changing personal hygiene habits.

Balancing these concerns is what keeps costs low and service levels high. The ABS EffeX range provides the most efficient, reliable operation possible – which gives you full peace of mind.

## Highly Effective Mixing

The ABS submersible mixer XRW provides high efficiency and excellent process control that can make a difference at various stages of wastewater treatment.

- **Equalization**

The objective of mixing during the equalization process is to blend the wastewater and to prevent sedimentation, stratification and odor formation. The ABS submersible mixer XRW is the best solution, as the water levels in this part of the process are often very low and have a tendency to change frequently. The configuration of the ABS submersible mixer XRW is determined by the intensity of mixing and flow required.

- **Selector (contact zone)**

In the selector tank the aim is to control and limit the growth of filamentous bacteria, which enhances the sludge sedimentation ability. The ABS submersible mixer XRW can be used for intensive (flash) mixing of the recirculated sludge and wastewater.

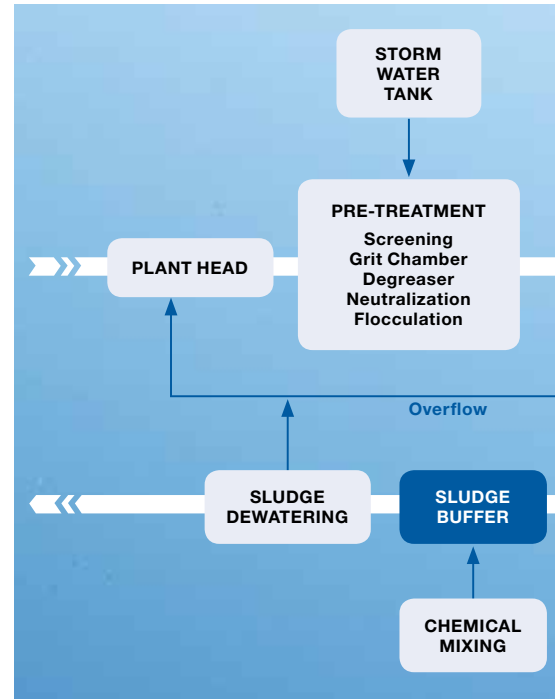

- **Biological processes**

- **(anaerobic and anoxic)**

In the anaerobic and anoxic tanks the biomass has to be kept in suspension in order to avoid the risk of the sludge settling and to maximize the active volume. The target is to provide good contact between the inlet wastewater, recirculated sludge and biomass. The ABS submersible mixer XRW can be used to provide sufficient mixing energy to keep the biomass in suspension.

- **Sludge buffer tank**

Blending and homogenization of concentrated primary, secondary or digested sludge are the most common applications in the sludge buffer tanks. The ABS submersible mixer XRW can be used successfully here.





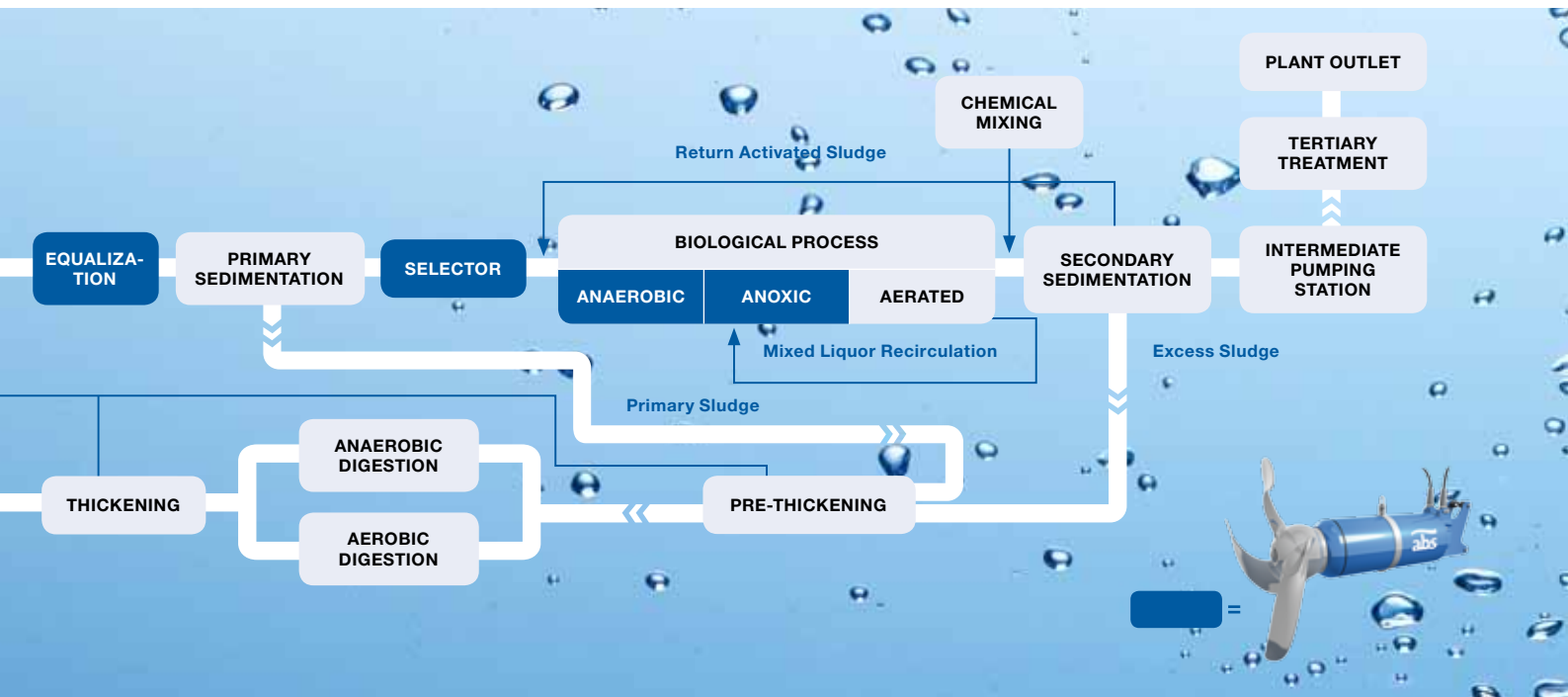

### The World-Class Range of Wastewater Products

The ABS Effex range from Sulzer Pumps is a complete portfolio of products designed to cover all key aspects of wastewater handling. It includes:

- Submersible sewage pumps
- Submersible mixers
- Submersible flow boosters
- Turbocompressors
- Modular pump control systems

All of these products employ premium-efficiency motors (IE3 or equivalent), as well as innovative features that ensure efficiency and reliability.

### Service Globally and Locally

Sulzer Pumps is a strong global organization, represented worldwide with a strong local presence.

We offer a complete Service Program, covering everything from on-site repair to full service maintenance contracts with alarm management and 24-hour breakdown services.

In addition, we have a sophisticated stocking system with international hub locations and on-hand stocks of key products. This ensures products are rapidly and reliably available whenever they are needed on site.

## ABS Submersible Mixer XRW

High Speeds	
Propeller diameter	210/300 mm
Rated motor power	0.8–3.5 kW
Mixer thrust up to	630 N

Medium Speeds	
Propeller diameter	400/650 mm
Rated motor power	2.5–10 kW
Mixer thrust up to	2450 N

Medium-Low Speeds	
Propeller diameter	900 mm
Rated motor power	11–25 kW
Mixer thrust up to	5800 N

# Combined Strength for Unmatched Expertise

ABS, associated with innovation and well proven solutions for wastewater handling and dewatering, is a product brand of Sulzer. Strong customer service combined

with extensive application expertise in solving wastewater and dewatering challenges is the foundation of this strong global brand. For more information, visit [www.sulzer.com](http://www.sulzer.com)

[www.sulzer.com](http://www.sulzer.com)

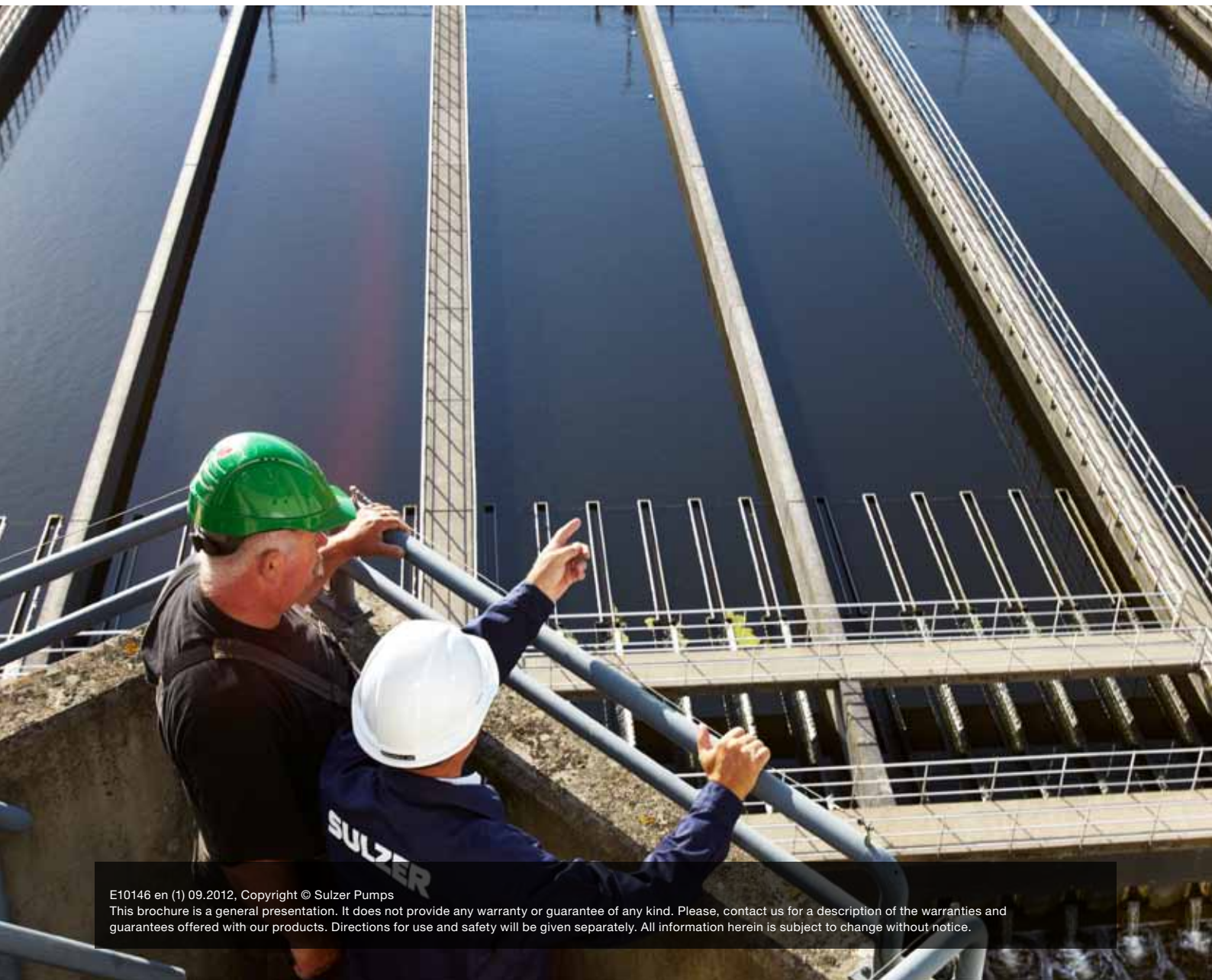

E10146 en (1) 09.2012, Copyright © Sulzer Pumps

This brochure is a general presentation. It does not provide any warranty or guarantee of any kind. Please, contact us for a description of the warranties and guarantees offered with our products. Directions for use and safety will be given separately. All information herein is subject to change without notice.