



# Cyclepods

Transforming bike storage



## WESTERHAM RACK INSTALLATION GUIDE

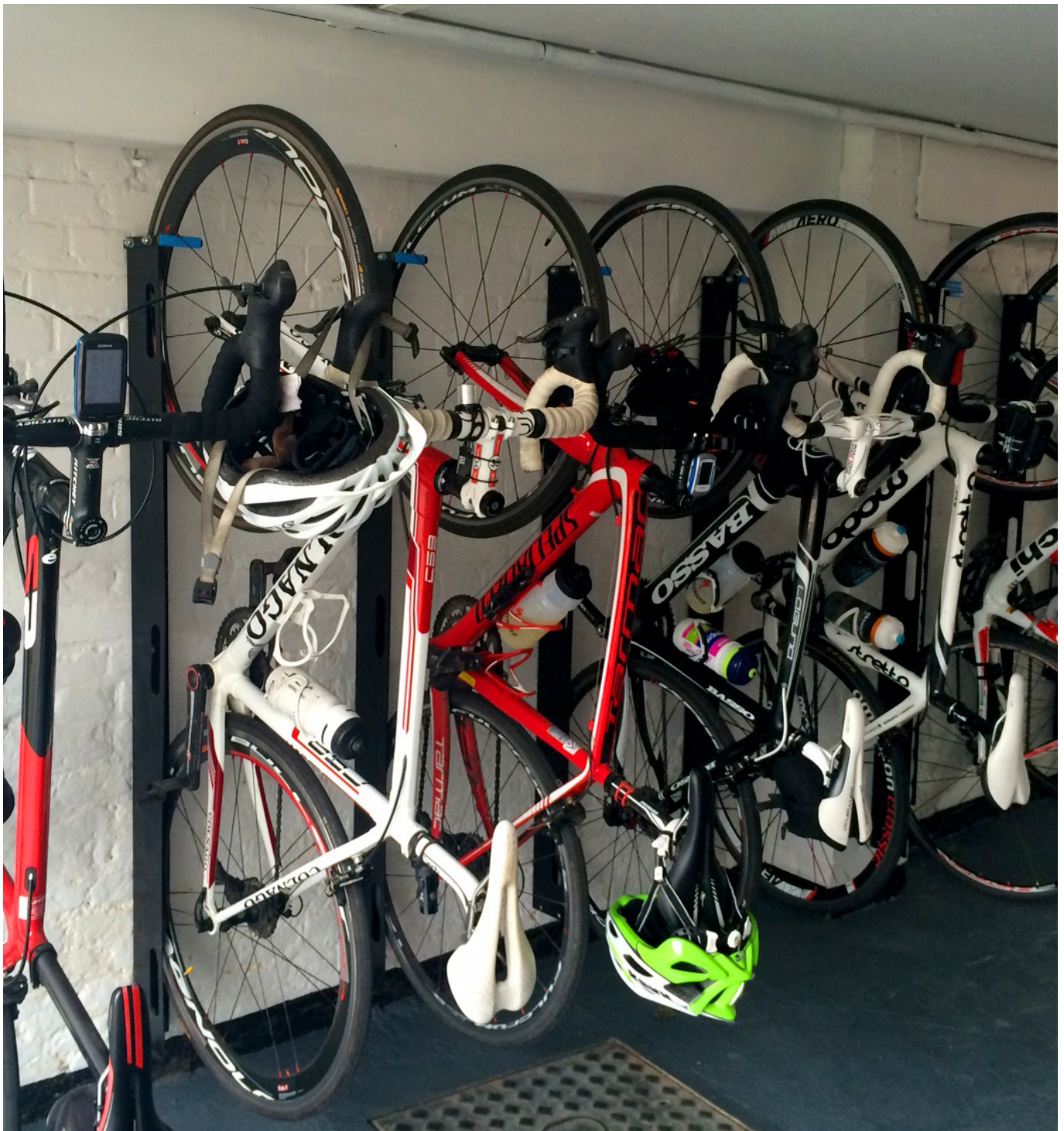

# SPACE PLANNING OPTIONS

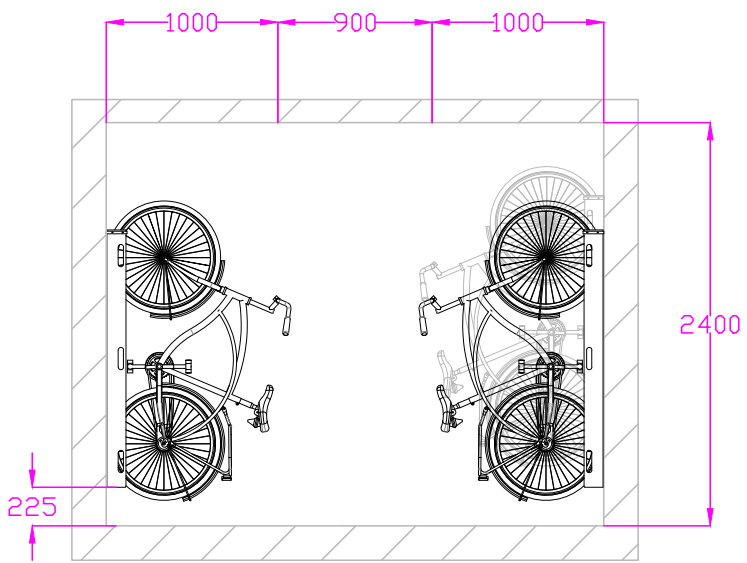
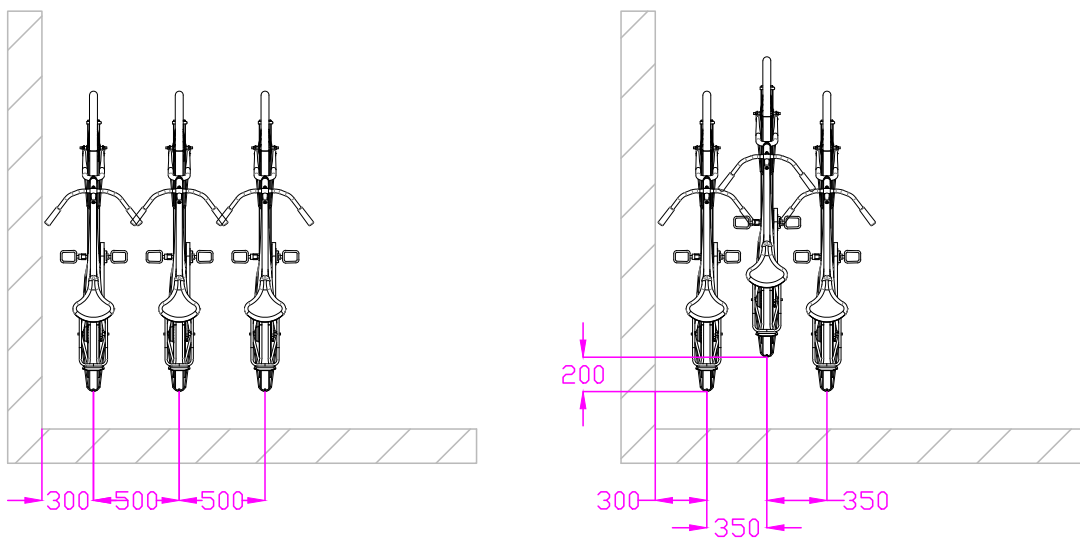
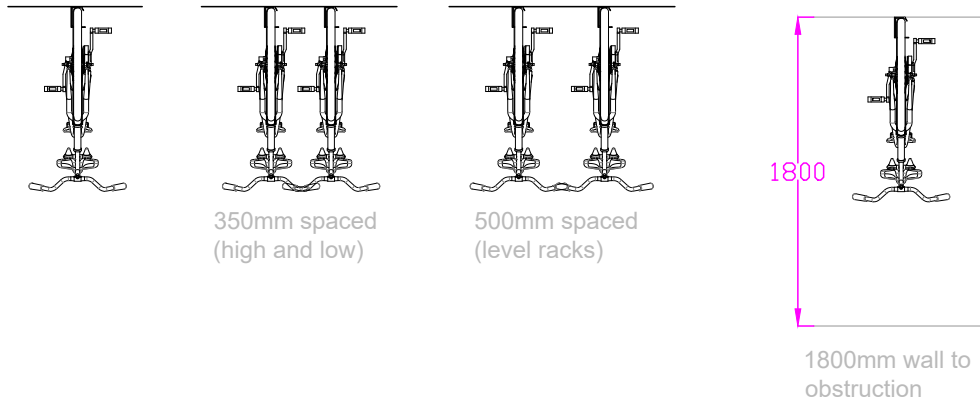

2m - 2.4m height required

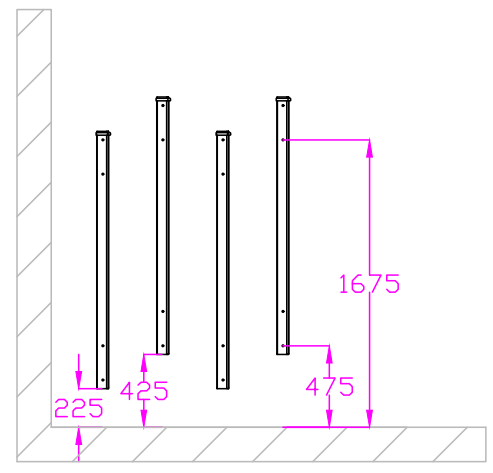

# 1. ASSEMBLE HANGER ARM TO MAIN CHANNEL

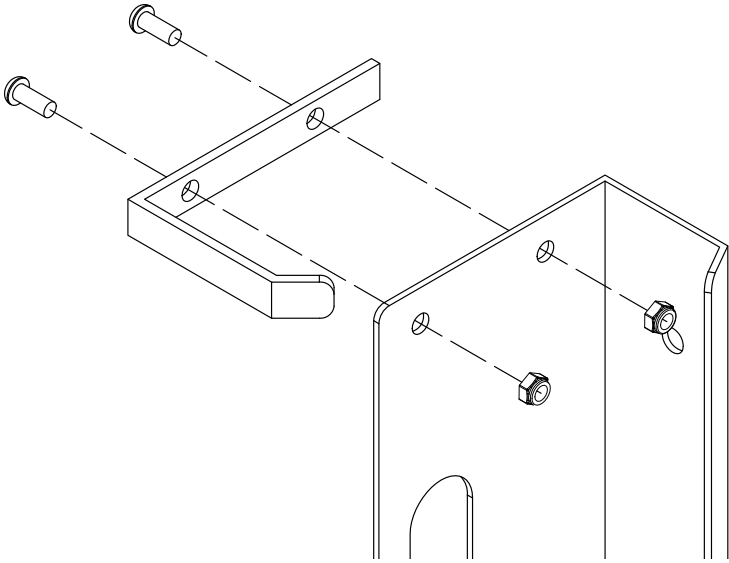

# 2. MARK OUT WALL

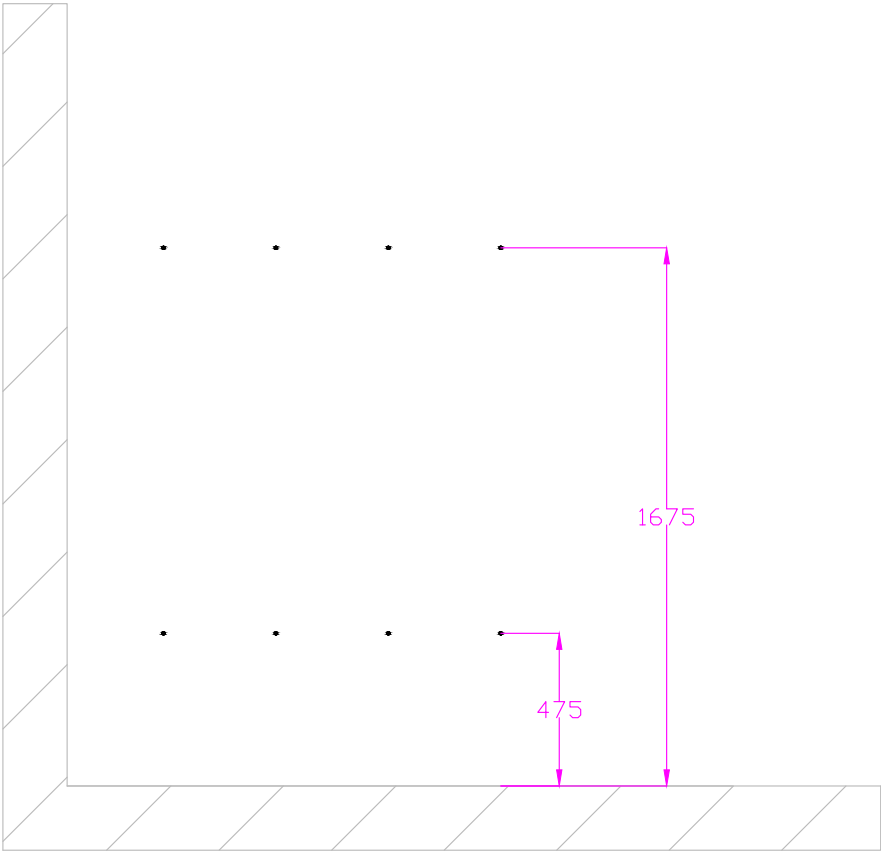

**3. DRILL HOLES FOR APPROPRIATE FIXINGS (WALL TYPE DEPENDANT)**

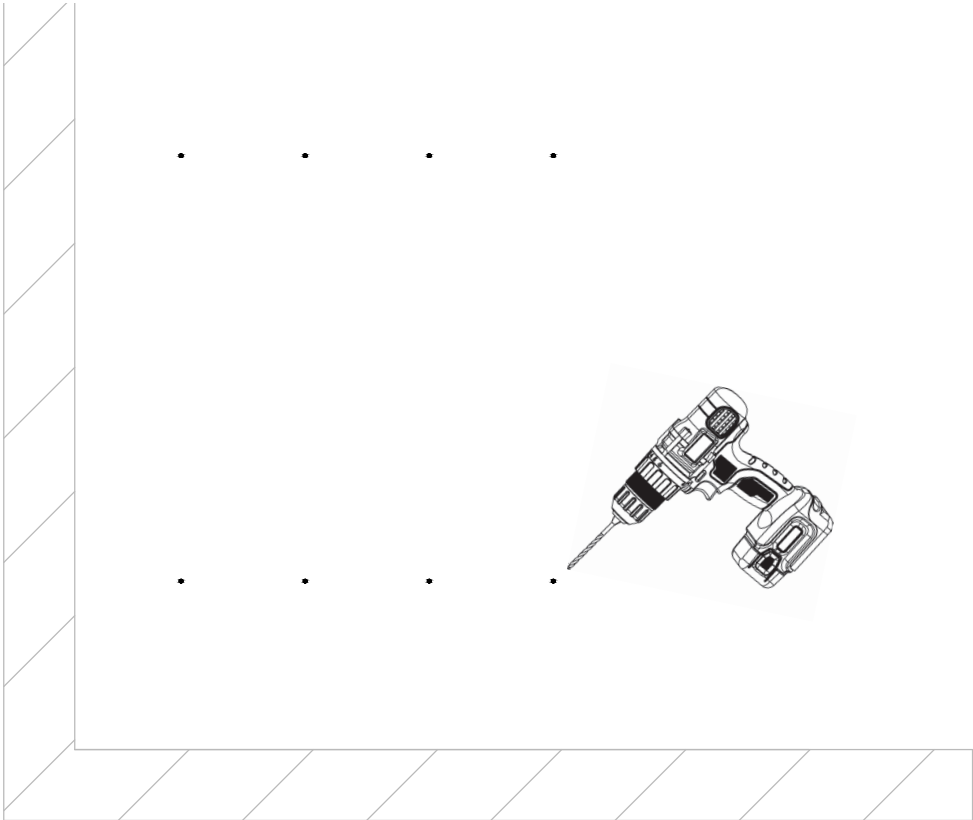

**4. USE 2 FIXINGS TO SECURE EACH WESTERHAM RACK TO WALL**

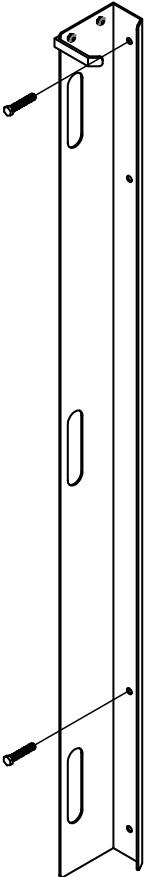

**CYCLEPODS LTD  
UNIT 2 BETSOMS BARN  
PILGRIMS WAY  
WESTERHAM  
KENT  
TN16 2DS**