

Frese PV-SIGMA Compact Dynamic Pressure and Flow Regulation

Description

The Frese PV-SIGMA Compact system is a dynamic valve arrangement designed to regulate flow and differential pressure.

Application

The Frese PV-SIGMA Compact system can be installed in both domestic and commercial heating and cooling systems.

The PV-SIGMA Compact combines the Frese SIGMA Compact dynamic balancing valve positioned in the flow and the Frese PV Compact differential pressure control valve positioned in the return.

Operation

The Frese PV-SIGMA Compact system ensures 100% flow and differential pressure regulation under all conditions, irrespective of any changes within the system whilst providing simple and trouble free commissioning.

The Frese PV-SIGMA Compact system operates by limiting the flow and pressure in a system, eliminating any noise caused by excess differential pressure.

Benefits

- Simple presetting of flow and differential pressure
- Flow and differential pressure can be adjusted independently of each other
- Differential pressure can be easily adjusted after installation
- Tamperproof presetting device fitted on the top of the differential pressure control valve
- No additional commissioning required if the system design is changed
- High levels of comfort and energy savings for the end user
- The PV Compact eliminates noise caused by high differential pressure whilst the SIGMA Compact limits the flow in a system, ensuring no overflows



Features

- Size range: DN15 to DN50
- Maximum flow: 10.3m³/h
- Maximum differential pressure 400kPa
- Setting ranges: 5kPa-30kPa, 20-60kPa and 20-80kPa
- Differential pressure regulation, flow regulation, drain and PT plugs as standard
- Isolation function on the SIGMA Compact
- Compact housings for easy installation

Frese PV-SIGMA Compact Dynamic Pressure and Flow Regulation

Design Frese PV-SIGMA Compact

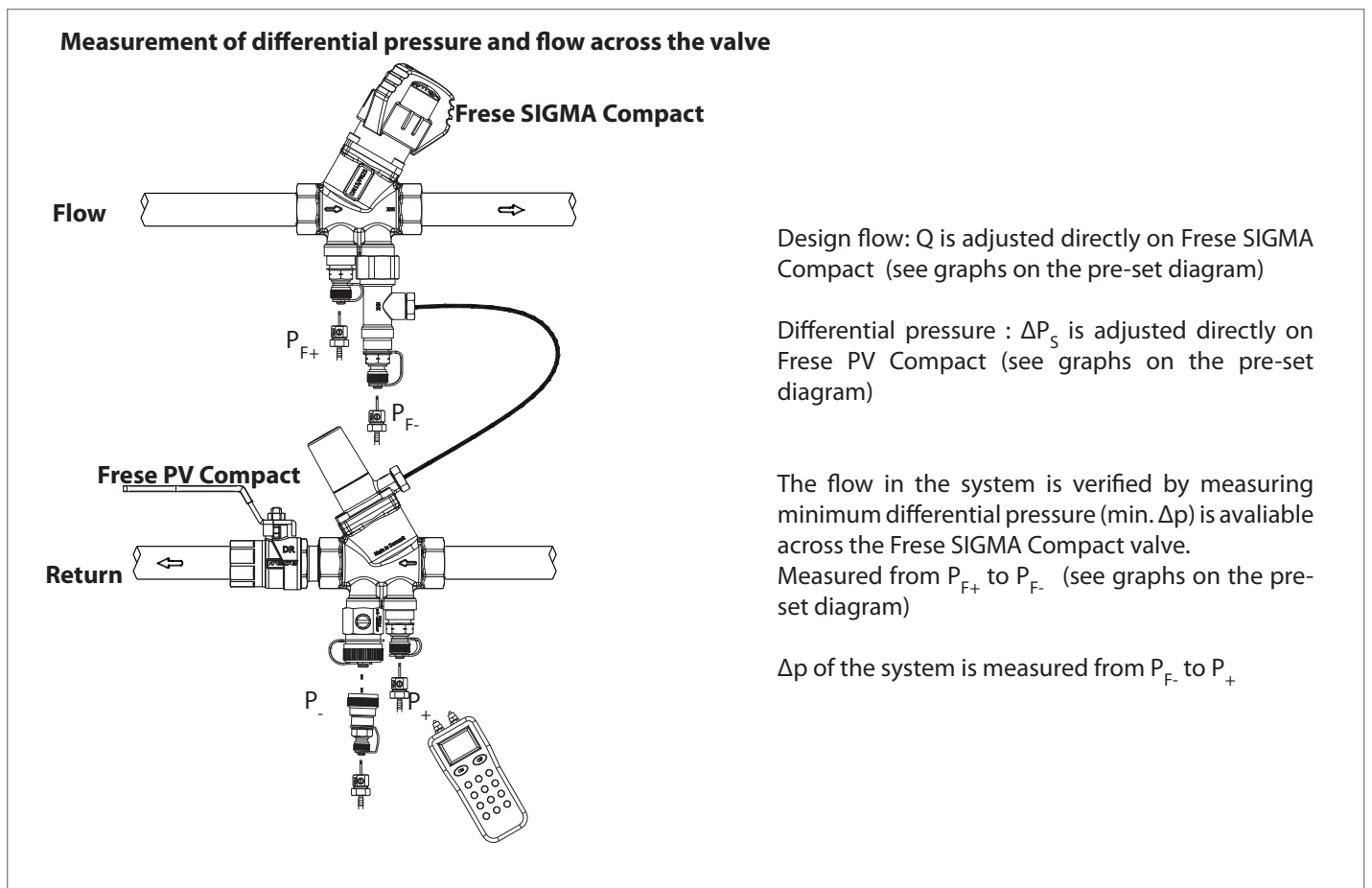
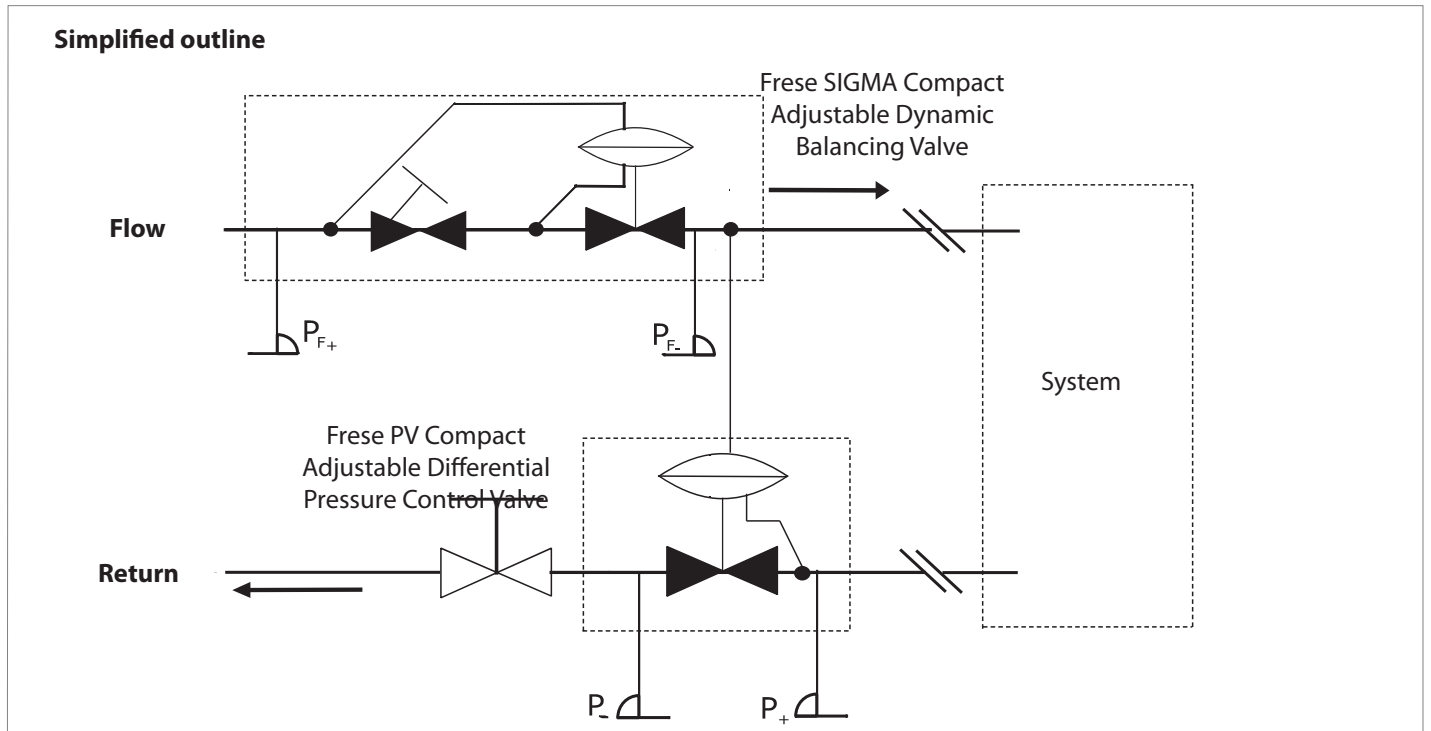

Frese PV-SIGMA Compact Dynamic Pressure and Flow Regulation

Technical data

Housing DN15-32:	DZR Brass, CW602N
DN40-50	Ductile Iron
DP controller:	PPS (40% glass)
Flow setting:	PA6 (20% glass)
Spring:	Stainless steel
Diaphragm:	HNBR
O-rings:	EPDM
Pressure class:	PN25
Max. differential pressure:	400 kPa
Temperature range:	-10°C to + 120°C
Capillary tube:	Ø3, L = 1000 mm

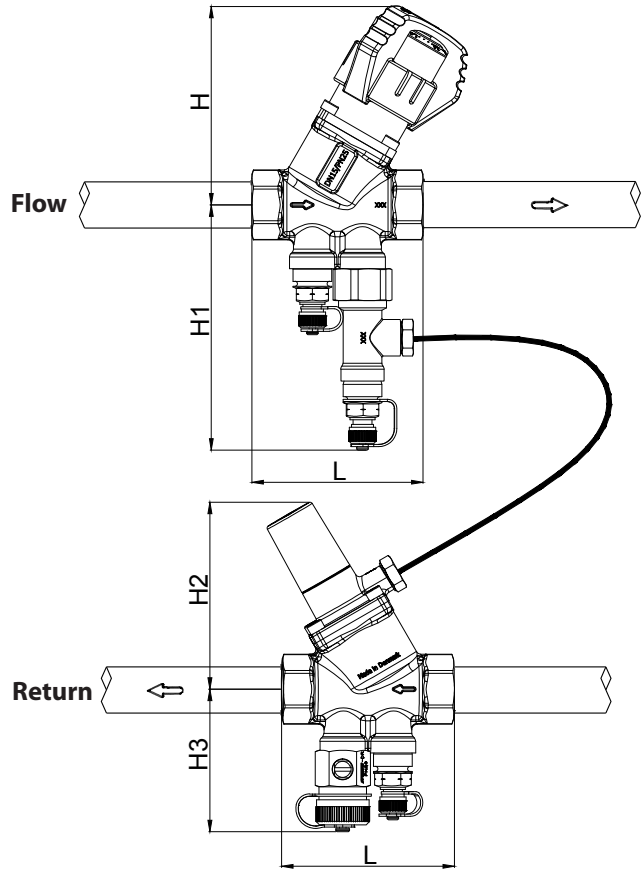

The pipe system shall be properly ventilated to avoid risk of air pockets. Glycolic mixtures up to 50% are applicable (both ethylene and propylene).
Recommendation: Water treatment to VDI 2035.

Frese PV-SIGMA Compact

Dimension		DN15		DN20		DN25		DN32	DN40	DN50
Version		Low	High	Low	High	Low	High	-	-	-
Control range	kPa	5-30	20-60	5-30	20-60	5-30	20-80	20-80	20-80	20-80
Flow range	l/s	0,014 - 0,167	0,028 - 0,278	0,028 - 0,278	0,042 - 0,536	TBC	0,208 - 0,536	0,278 - 1,389	0,833 - 2,056	1,389 - 2,875
	l/h	50 - 600	100 - 1000	100 - 1000	150 - 1930	TBC	750 - 1930	1000 - 5000	3000 - 7400	5000 - 10350
	gpm	0,22 - 2,64	0,44 - 4,40	0,44 - 4,40	0,66 - 8,50	TBC	3,30 - 8,50	4,40 - 22,01	13,21 - 32,58	22,01 - 45,57
Dimension mm	L	75		79		78	100	104	138	138
	H	87		87		90	110	110	131	131
	H1	108		108		108	114	119	121	127
	H2	82		82		82	134	134	156	156
	H3	66		66		66	72	77	80	86

Frese PV-SIGMA Compact Dynamic Pressure and Flow Regulation

Product programme

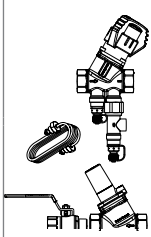
	Dimension	DN15	DN20	DN25	DN32	DN40	DN50
Frese PV-SIGMA Compact with drain valve, P/T plugs and capillary tube.		53-3260	53-3262	53-3264	53-3266 20-80 kPa	53-3267	53-3268
		Low 5-30 kPa	Low 5-30 kPa	Low 5-30 kPa		Low 20-80 kPa	Low 20-80 kPa
		53-3261	53-3263	53-3265			
		High 20-60 kPa	High 20-60 kPa	High 20-80 kPa			

Accessories

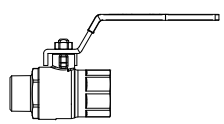
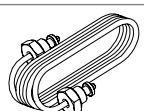
	Female/Male	Dimensions	Frese no.
Isolation ball valve		DN15	38-5020
		DN20	38-5022
		DN25	38-5024
		DN32	38-5026
		DN40	38-5028
		DN50	38-5030
Frese capillary tube ø3mm x 1000 mm		-	48-0004

Frese PV-SIGMA Compact Dynamic Pressure and Flow Regulation

Example: Pre setting the valves

**Frese PV-SIGMA Compact DN15 Low
Differential pressure system
(ΔP_s) 12 kPa**

Design flow 500 l/h (0,139 l/s)

Differential pressure setting Frese PV Compact

1. The design flow is used as the point of reference for the setting. (See the graph)
2. In order to make reading easier the graphs indicating the pressure in the circuit are arranged at intervals of 5 kPa. Still, the graphs can be offset according to the specified pressure of 12 kPa in our circuit. From the intersection of the 12 kPa graph and the horizontal line indicating 500 l/h a line perpendicular to the x-axis is made to read the pre-set value. Pre-set app. 6 turns on the scale.

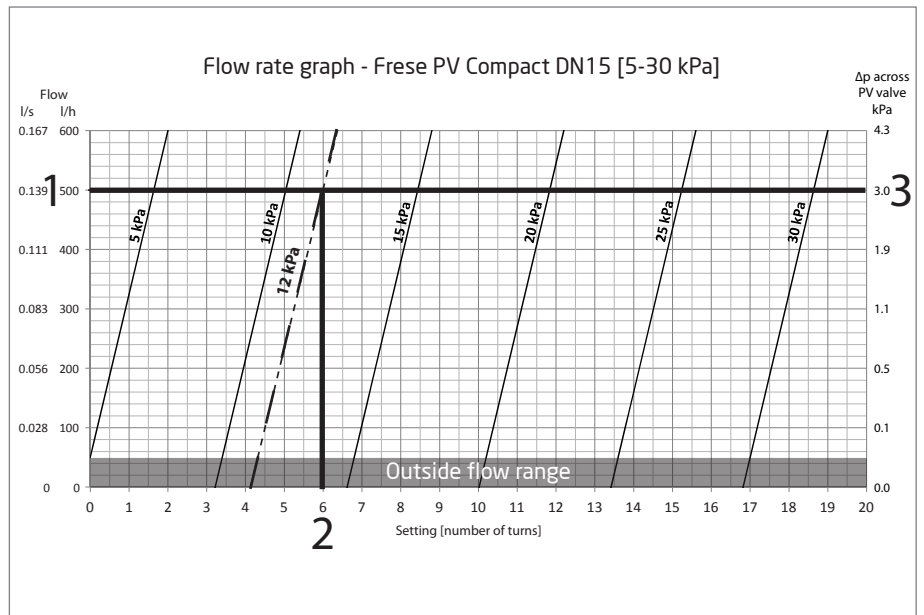

3. The minimum pressure drop required will be 3.0 kPa across the valve. (ΔP_{V2})

Flow setting Frese SIGMA Compact DN15 Low

Design flow 500 l/h (0,139 l/s)

1. The design flow is used as the point of reference for the setting. (See the graph)
2. The pre-setting for the valve is found by means of the flow rate graph. Setting = 2.2
3. The minimum pressure drop required will be 11 kPa across the valve. (ΔP_{V1})

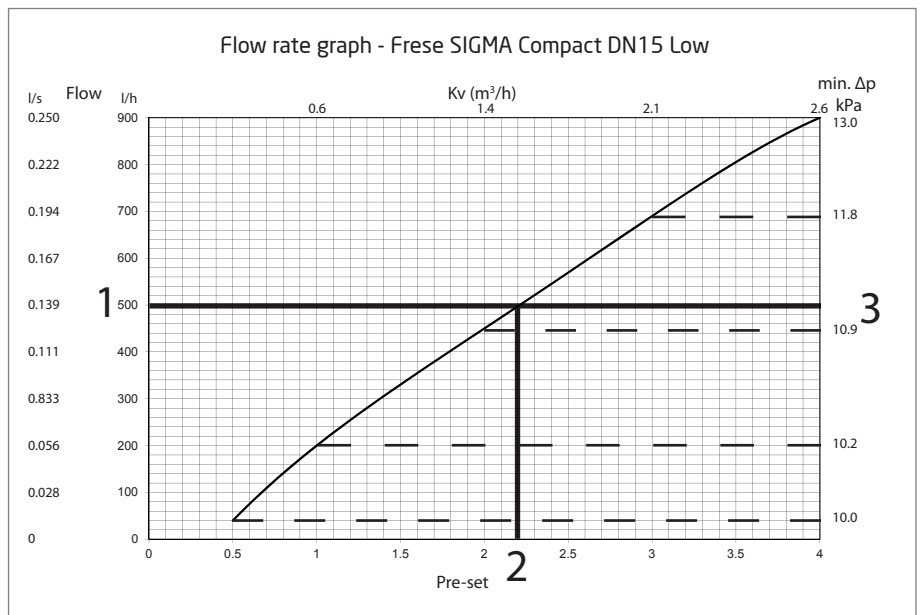

Frese PV-SIGMA Compact Dynamic Pressure and Flow Regulation

Example: Outline of a heating system - 3 blocks with 3 flats in each

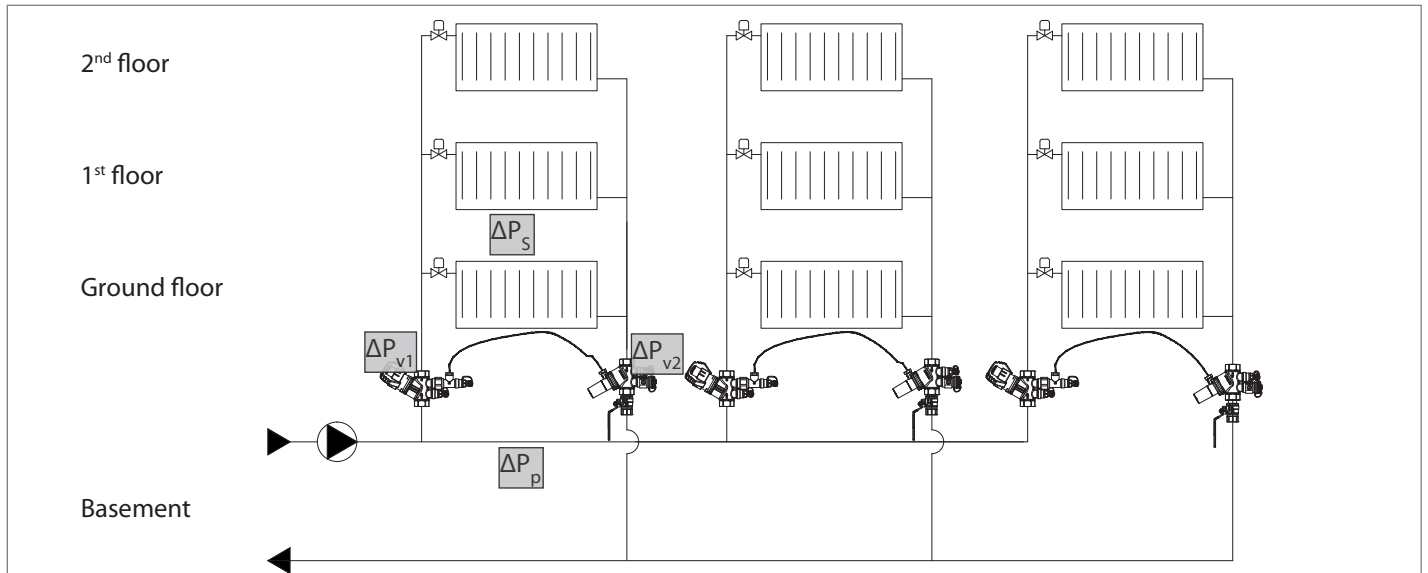

Total pump pressure

From the examples on the previous pages, the total required pump pressure for the block can now be calculated:

$$\Delta P_p = \Delta P_s + (\Delta P_{v1+v2}) \rightarrow \Delta P_p = 12 \text{ kPa} + (11 \text{ kPa} + 3 \text{ kPa}) = \mathbf{26 \text{ kPa}}$$

Example: Differential pressure change due to P-band

As the flow is reduced in the circuit in question the pressure increases in reverse ratio to the flow, which is due to the P-band of the adjustment spring.

The valve compensates for this, however the pressure will at no point in the circuit be as high as the pump pressure that would have been available, if Frese PV Compact had not been installed.

In this example the pressure increases to approx. 14 kPa as the graph is offset parallel to the course of flow. Furthermore, you can always read from the graph what the pressure in the circuit will be at any flow rate below the rated 500 l/h.

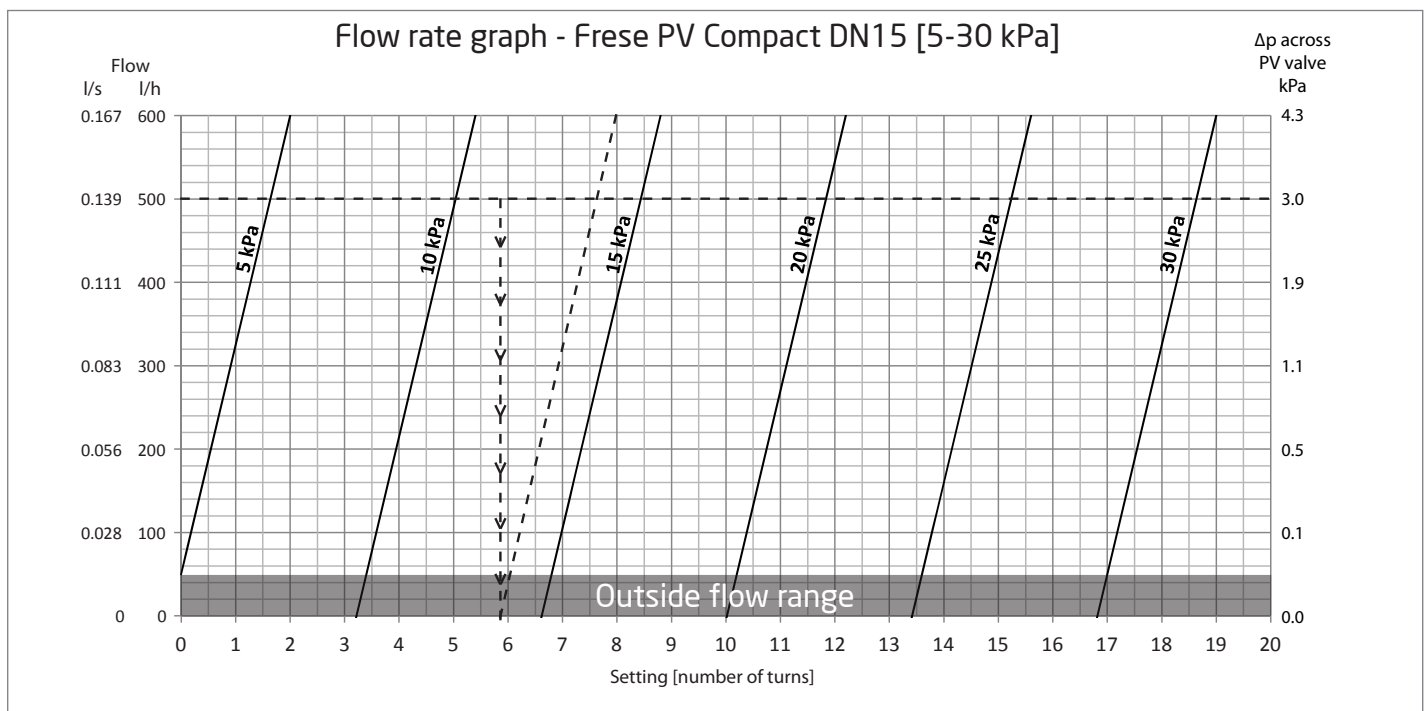

Frese PV-SIGMA Compact Dynamic Pressure and Flow Regulation

Frese PV Compact DN15, 5-30 kPa

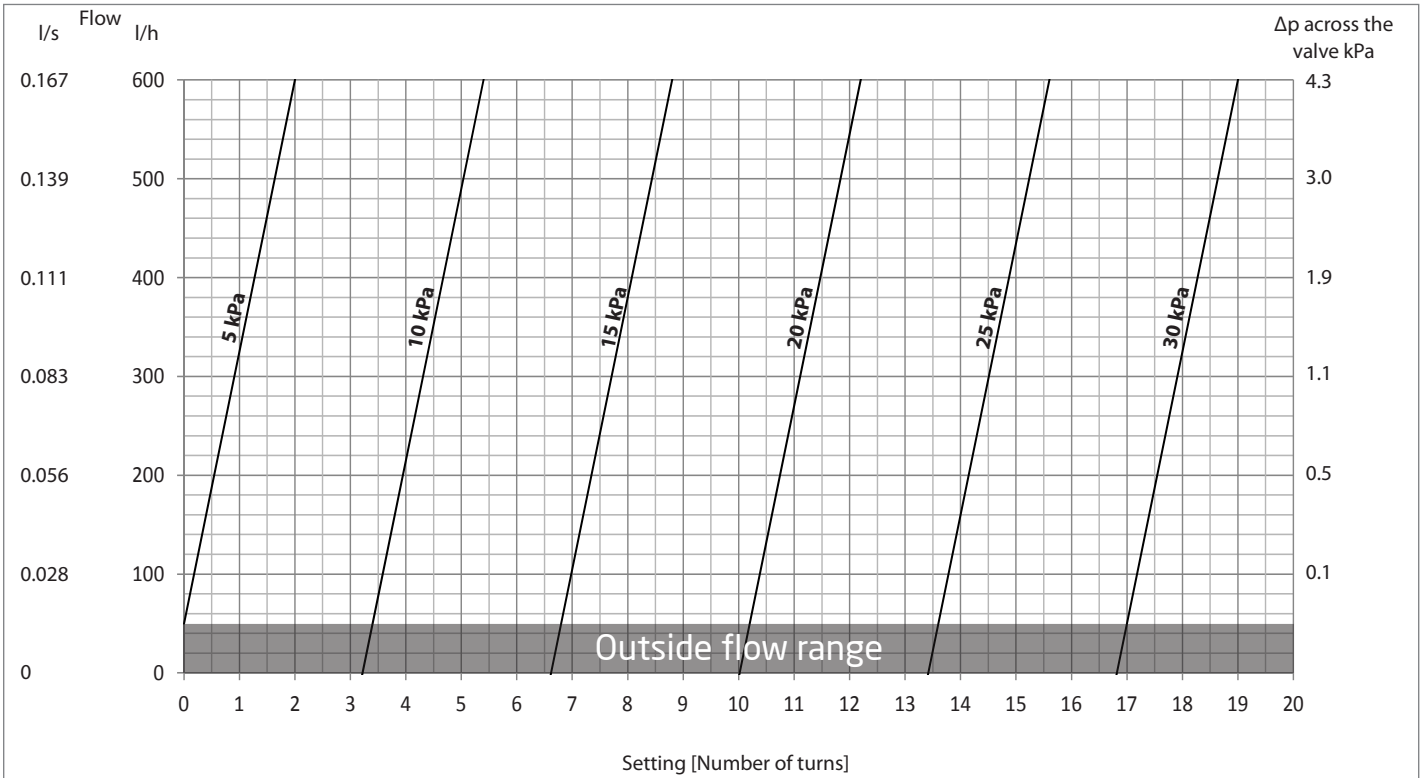

Frese SIGMA Compact DN15 Low

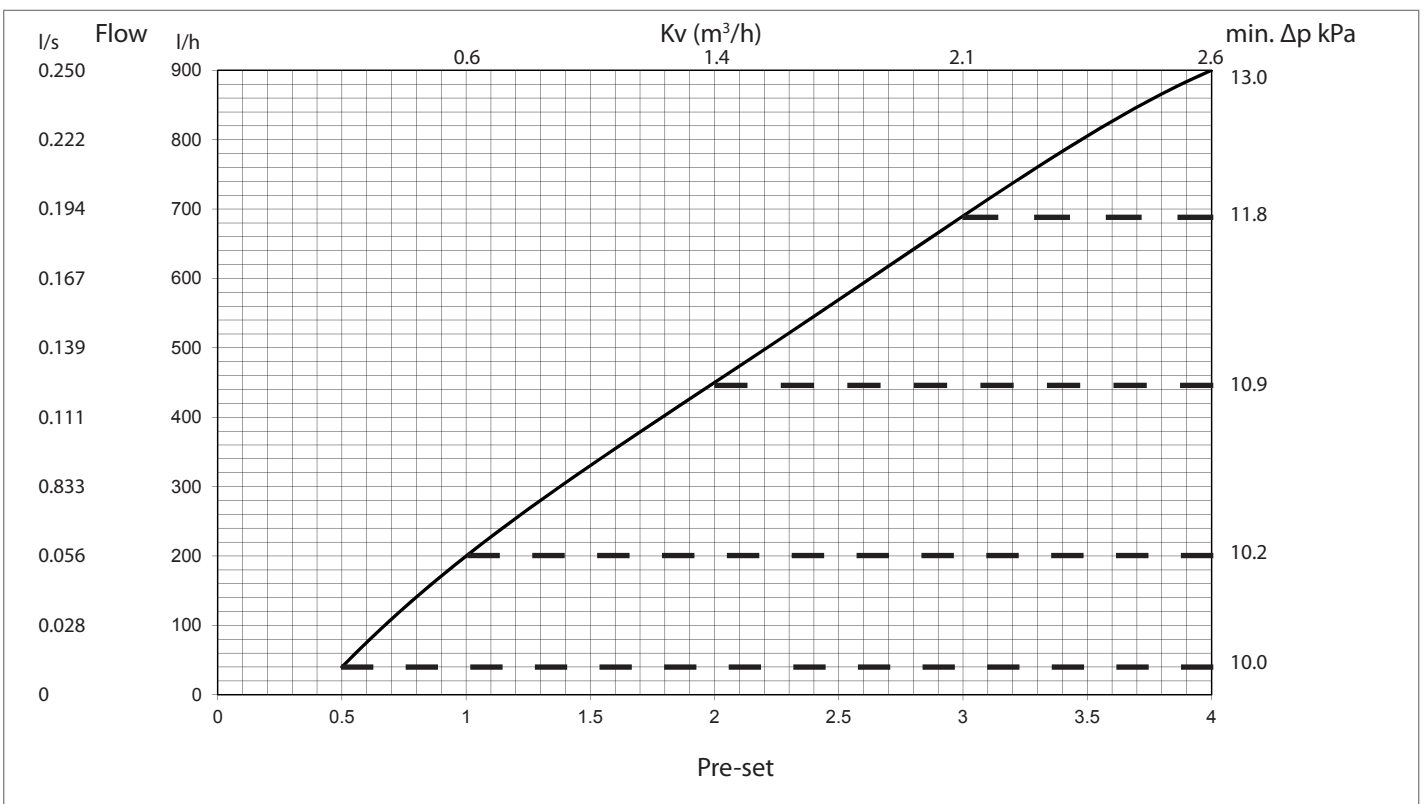

Frese PV-SIGMA Compact Dynamic Pressure and Flow Regulation

Frese PV Compact DN15, 20-60 kPa

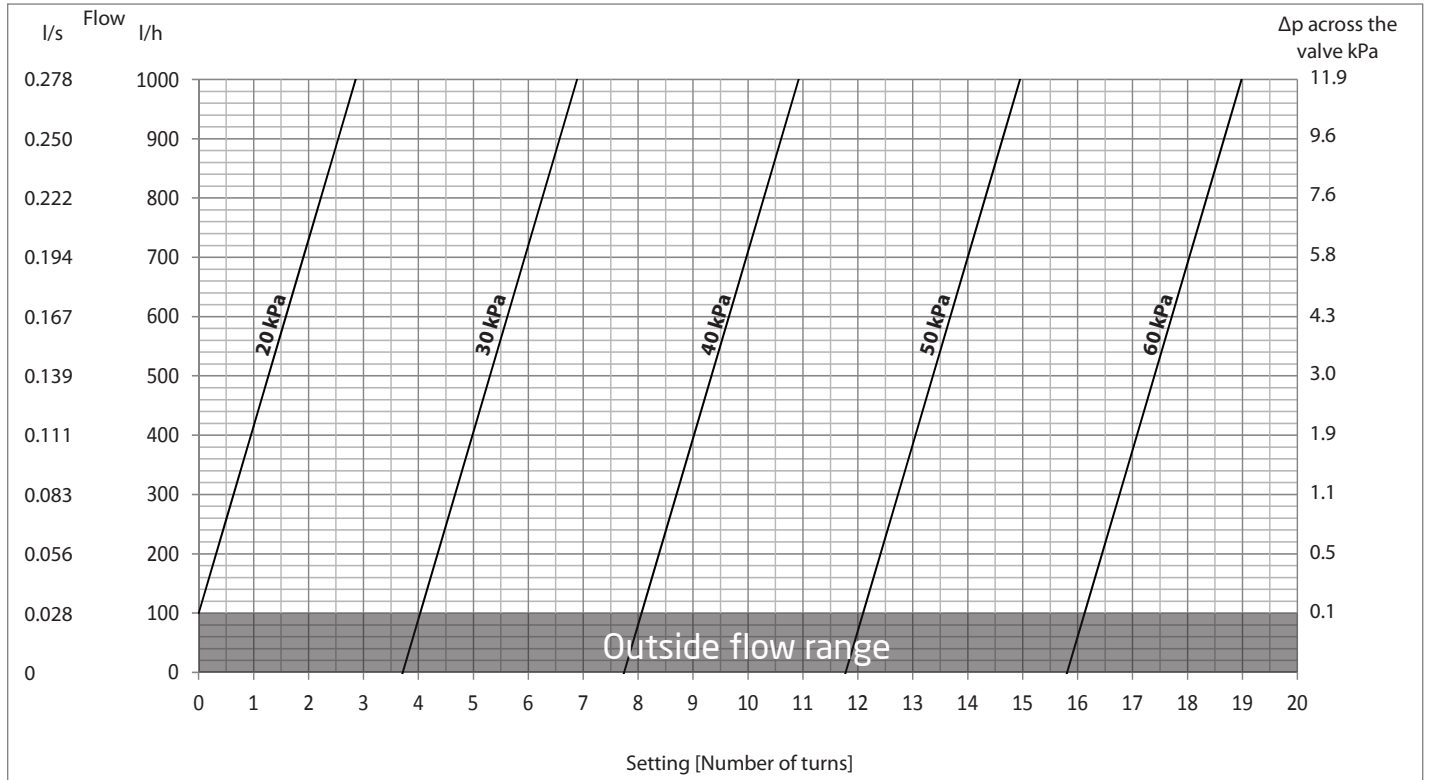

Frese SIGMA Compact DN15 High

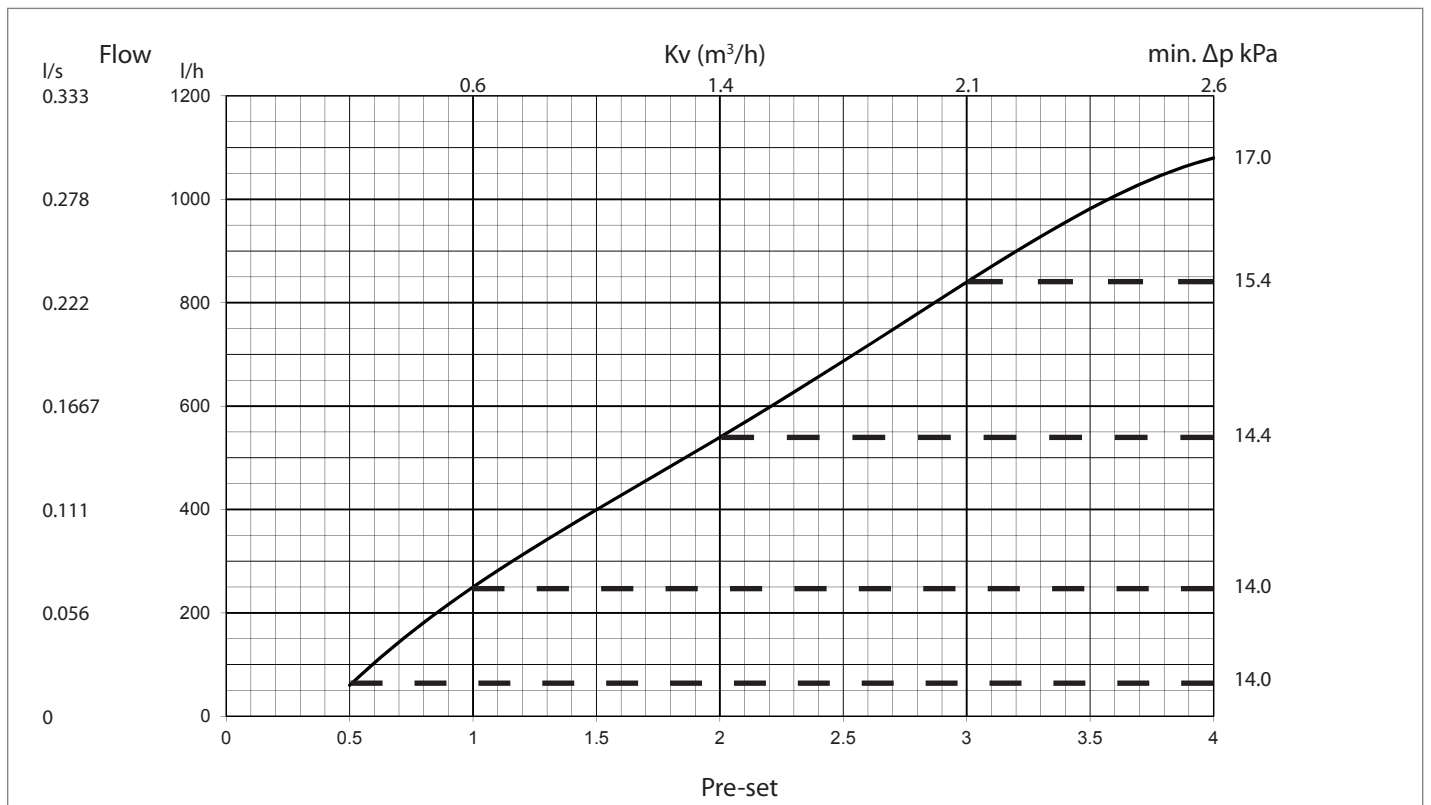

Frese PV-SIGMA Compact Dynamic Pressure and Flow Regulation

Frese PV Compact DN20, 5-30 kPa

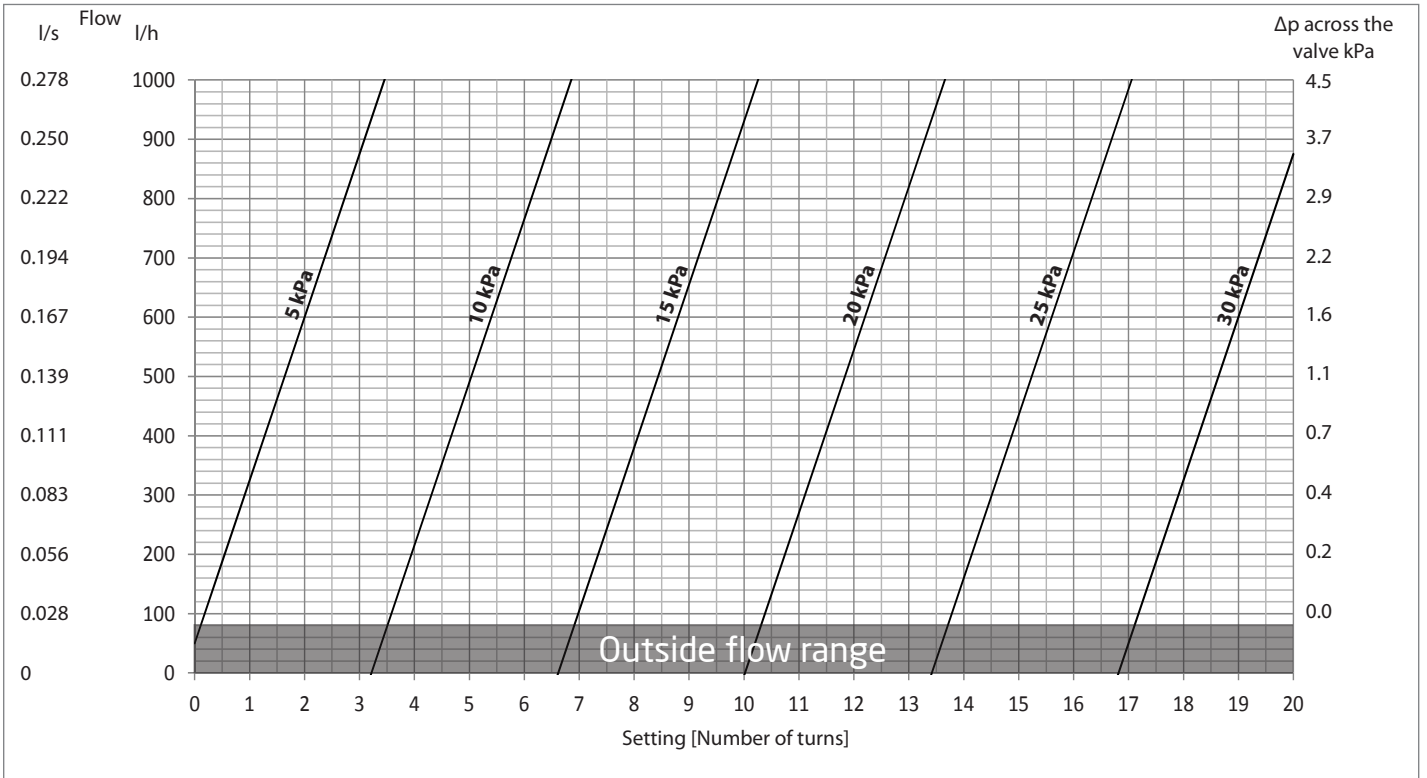

Frese SIGMA Compact DN20 Low

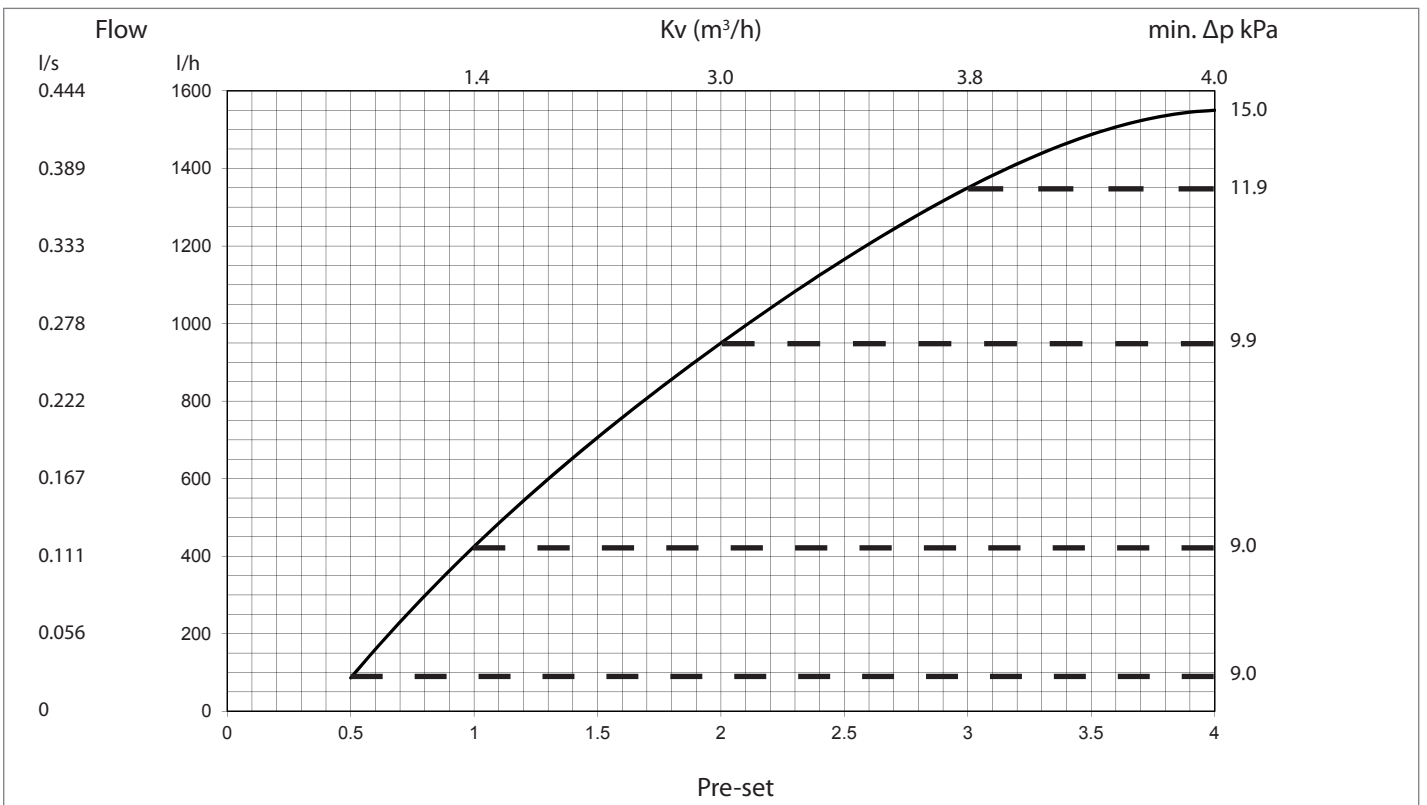

Frese PV-SIGMA Compact Dynamic Pressure and Flow Regulation

Frese PV Compact DN20, 20-60 kPa

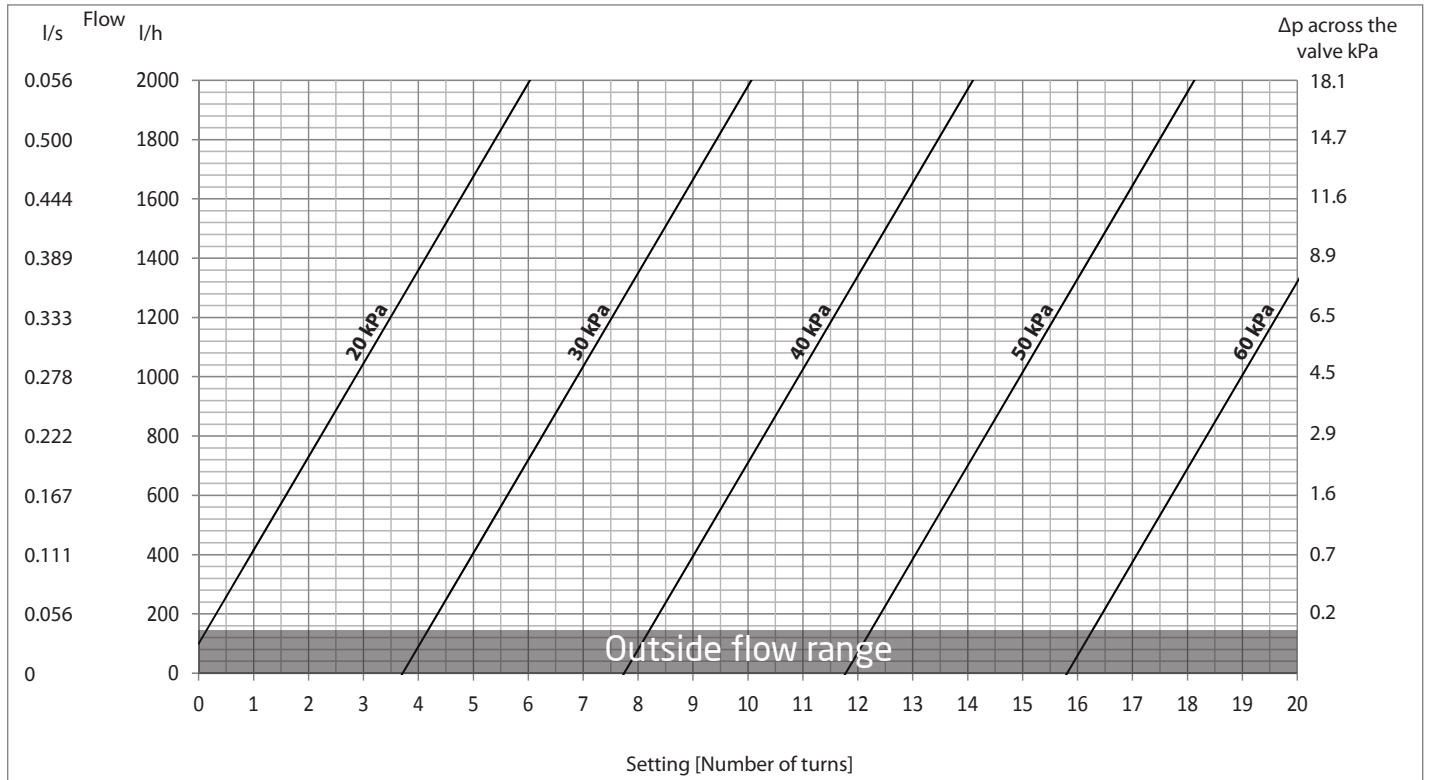

Frese SIGMA Compact DN20 High

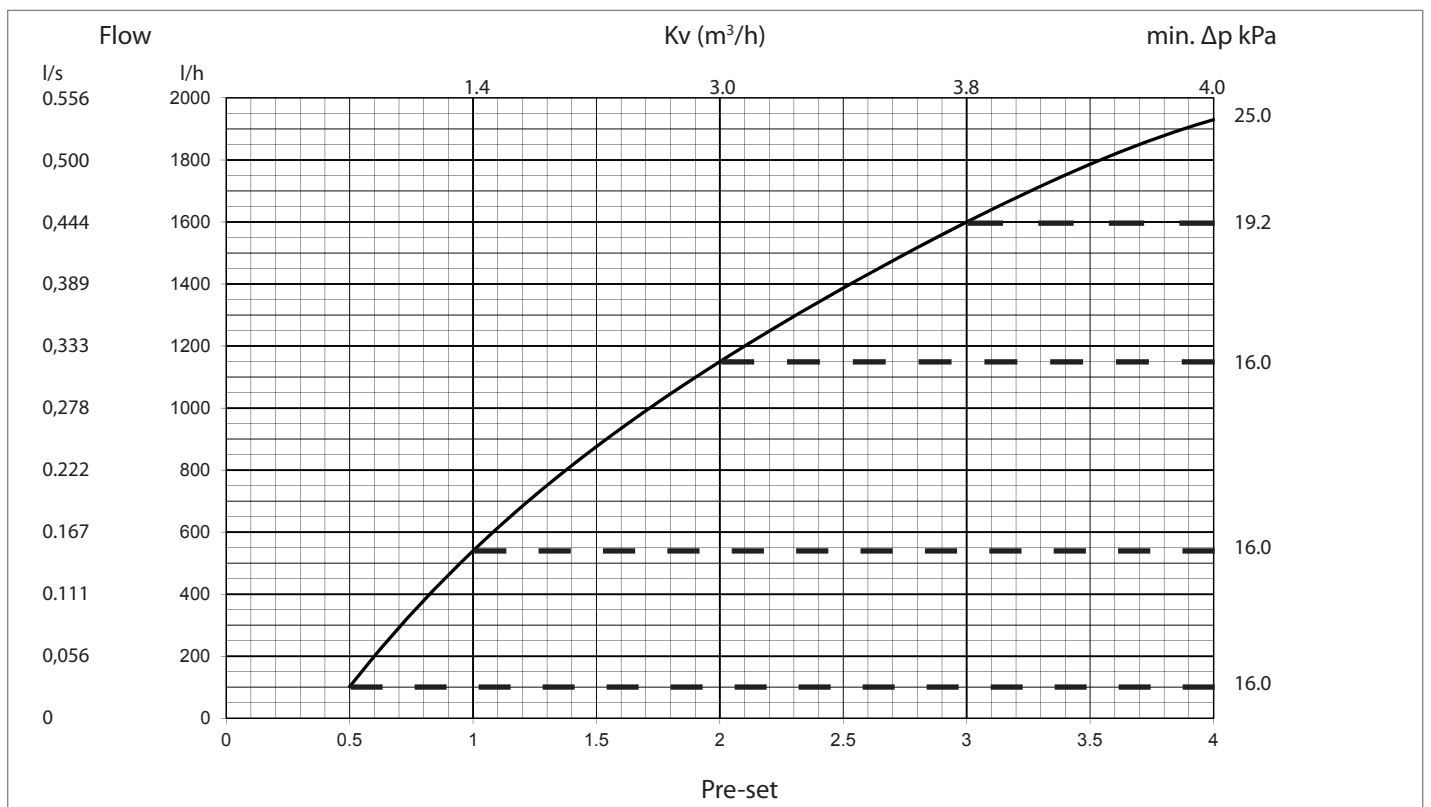

Frese PV-SIGMA Compact Dynamic Pressure and Flow Regulation

Frese PV Compact DN25L, 20-80 kPa

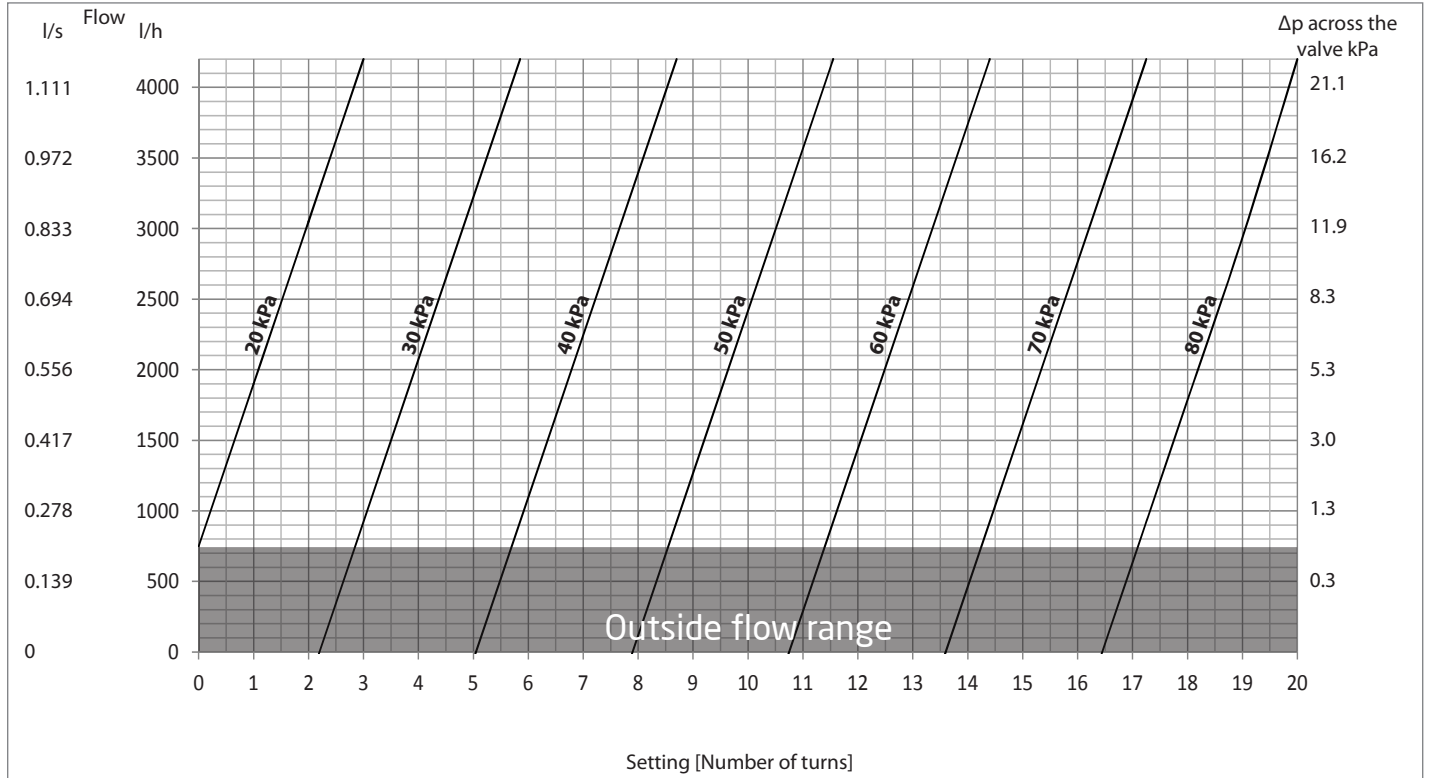

Frese SIGMA Compact DN25L High

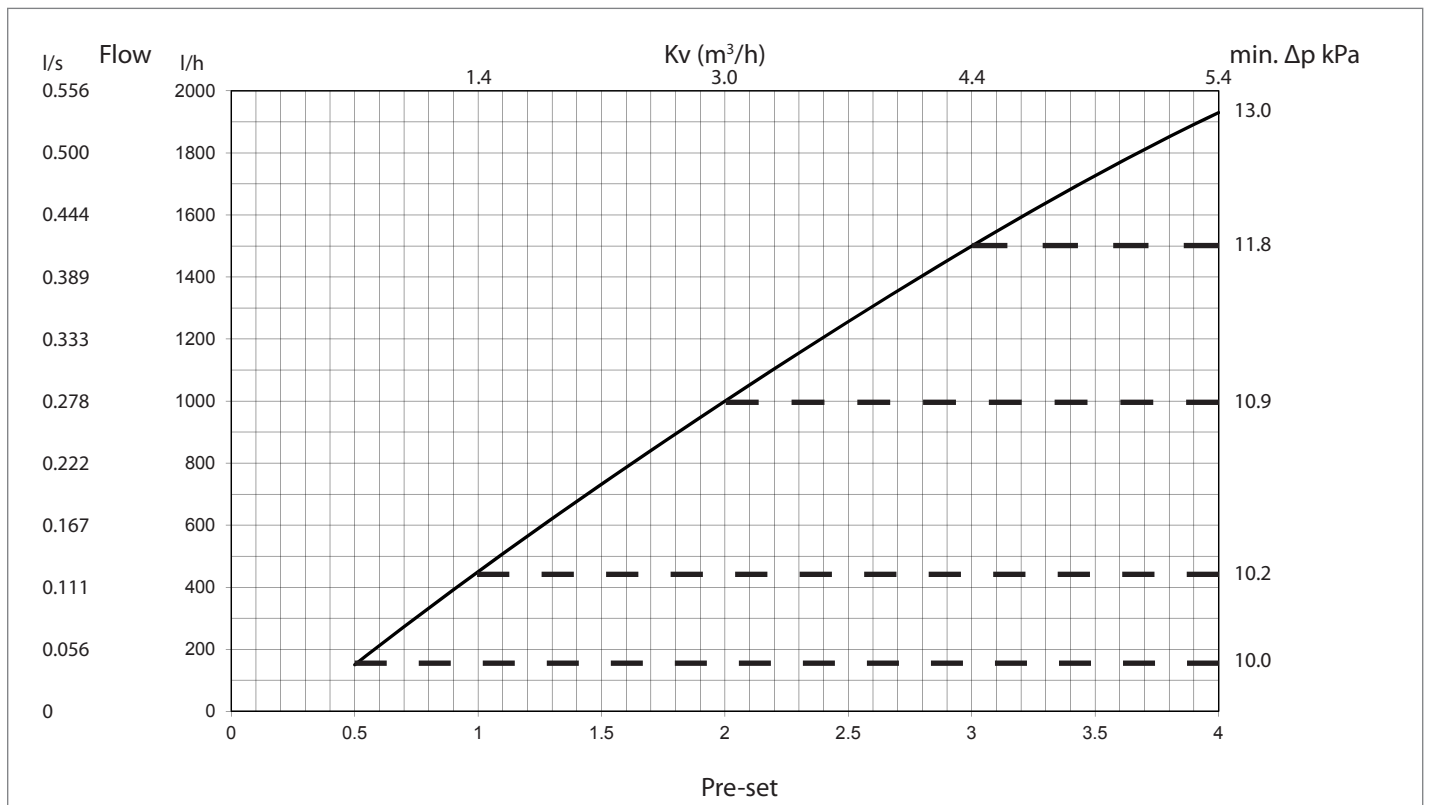

Frese PV-SIGMA Compact Dynamic Pressure and Flow Regulation

Frese PV Compact DN32, 20-80 kPa

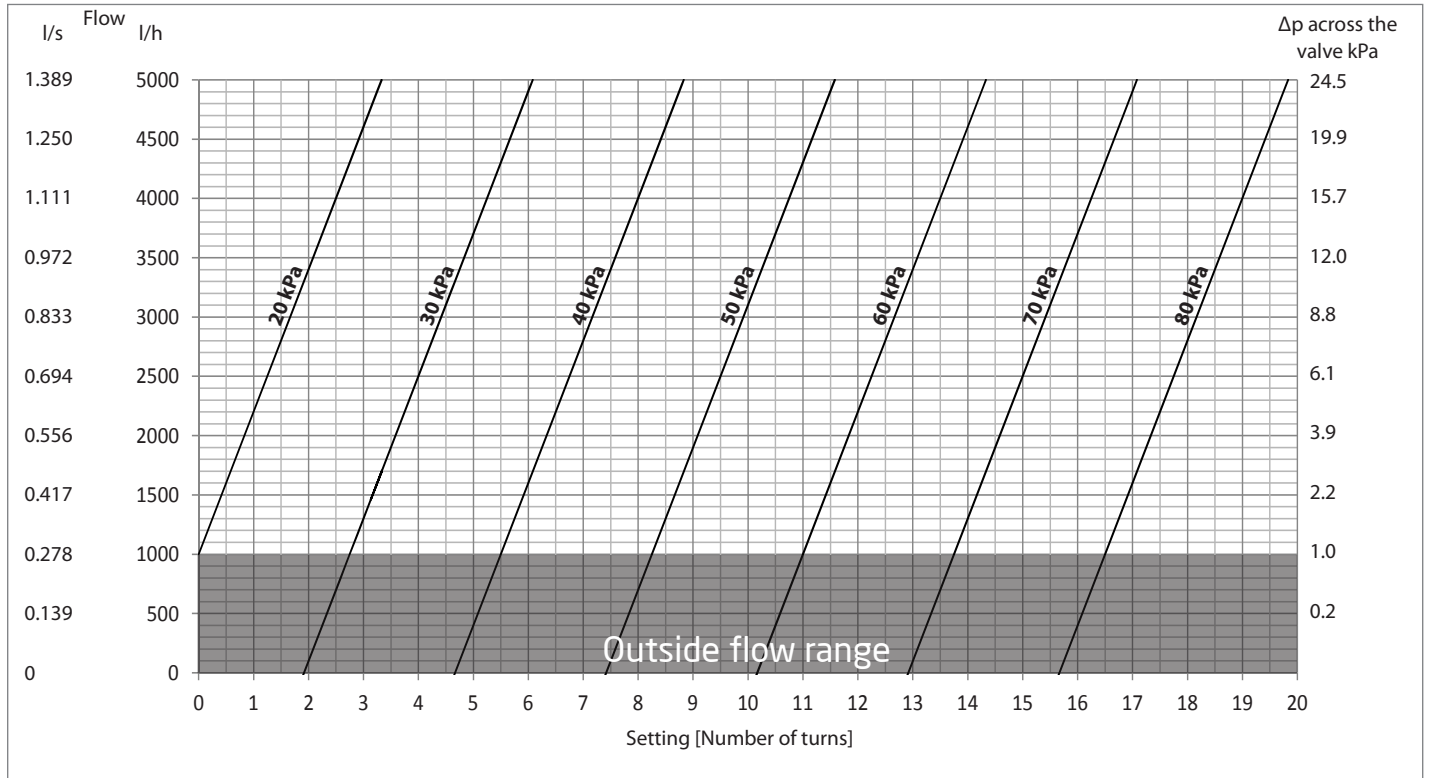

Frese SIGMA Compact DN32

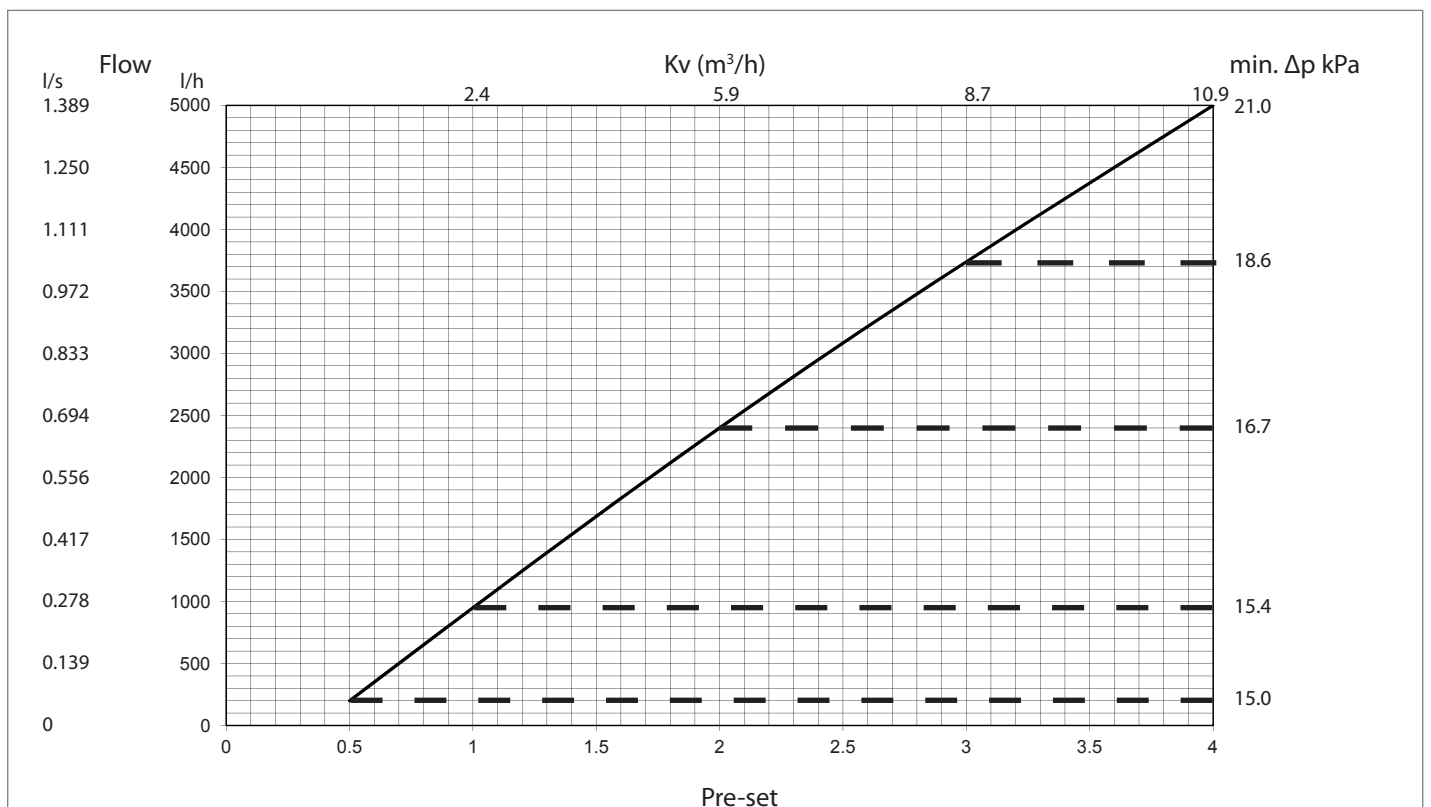

Frese PV-SIGMA Compact Dynamic Pressure and Flow Regulation

Frese PV Compact DN40, 20-80 kPa

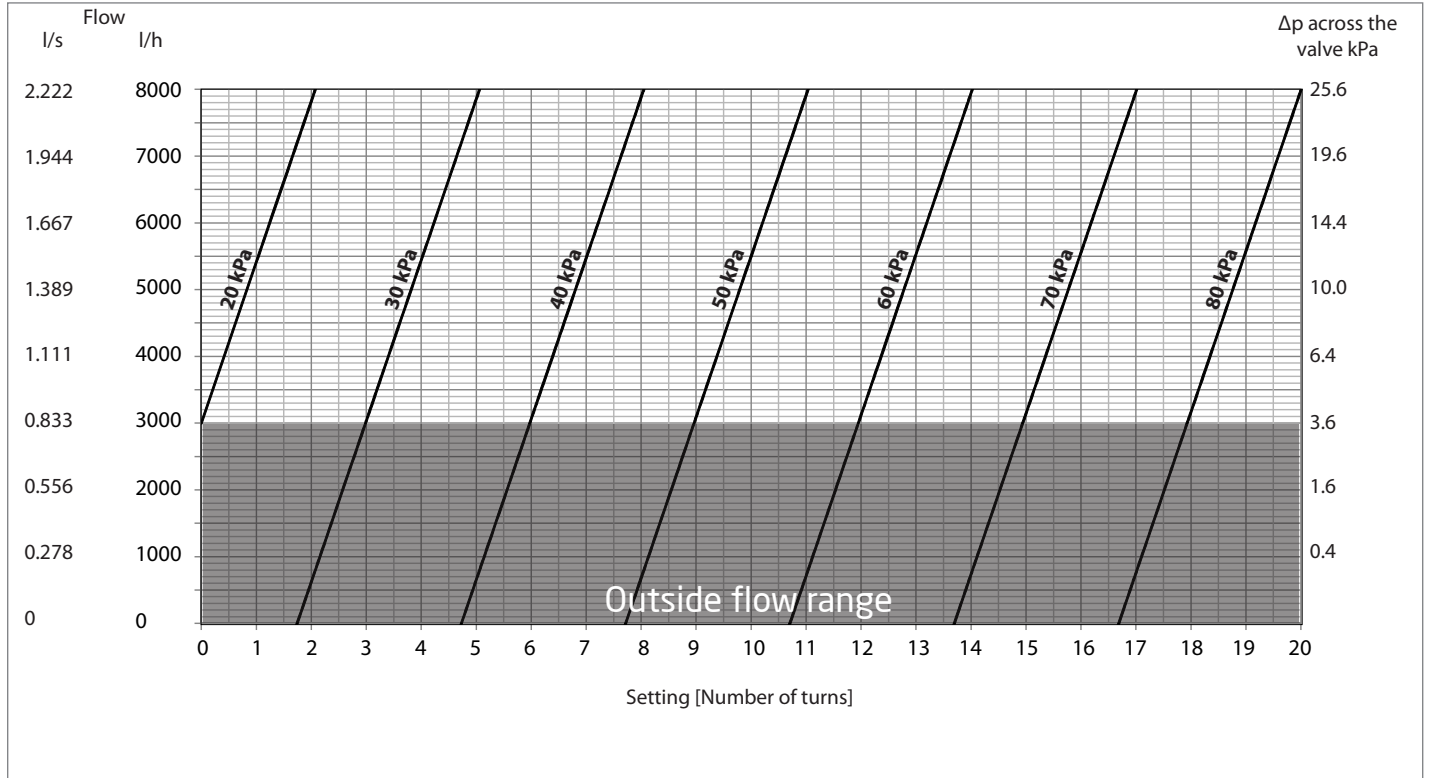

Frese SIGMA Compact DN40

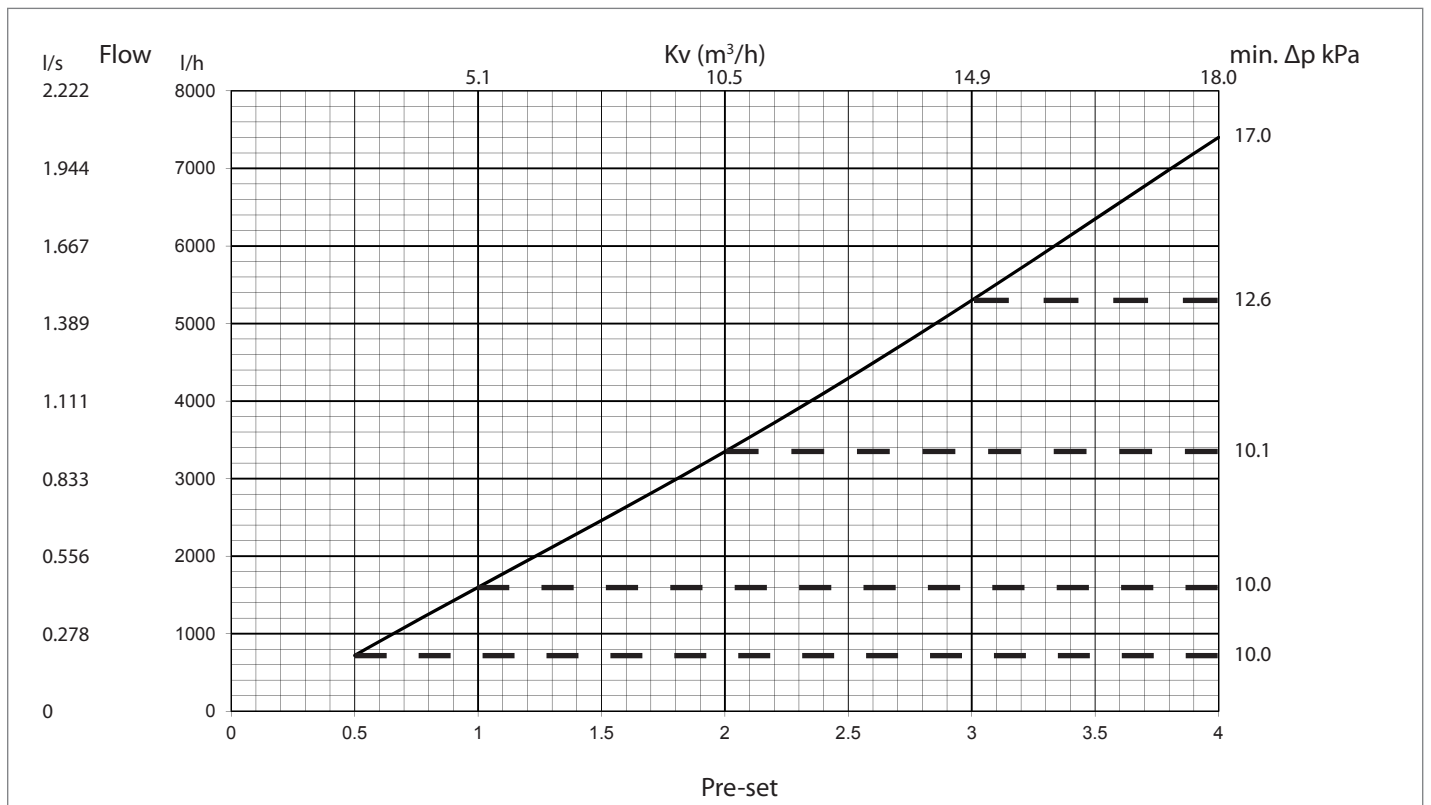

Frese PV-SIGMA Compact Dynamic Pressure and Flow Regulation

Frese PV Compact DN50, 20-80 kPa

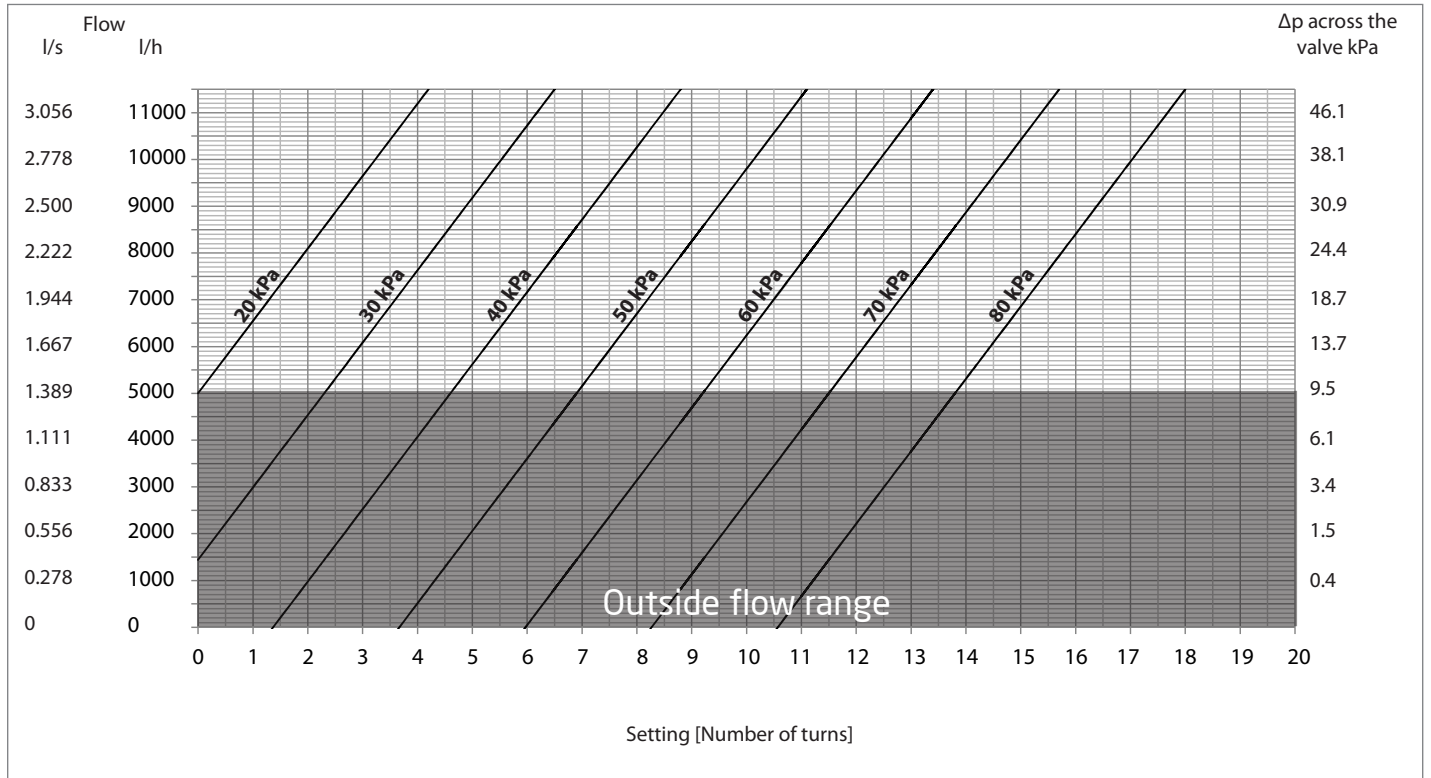

Frese SIGMA Compact DN50

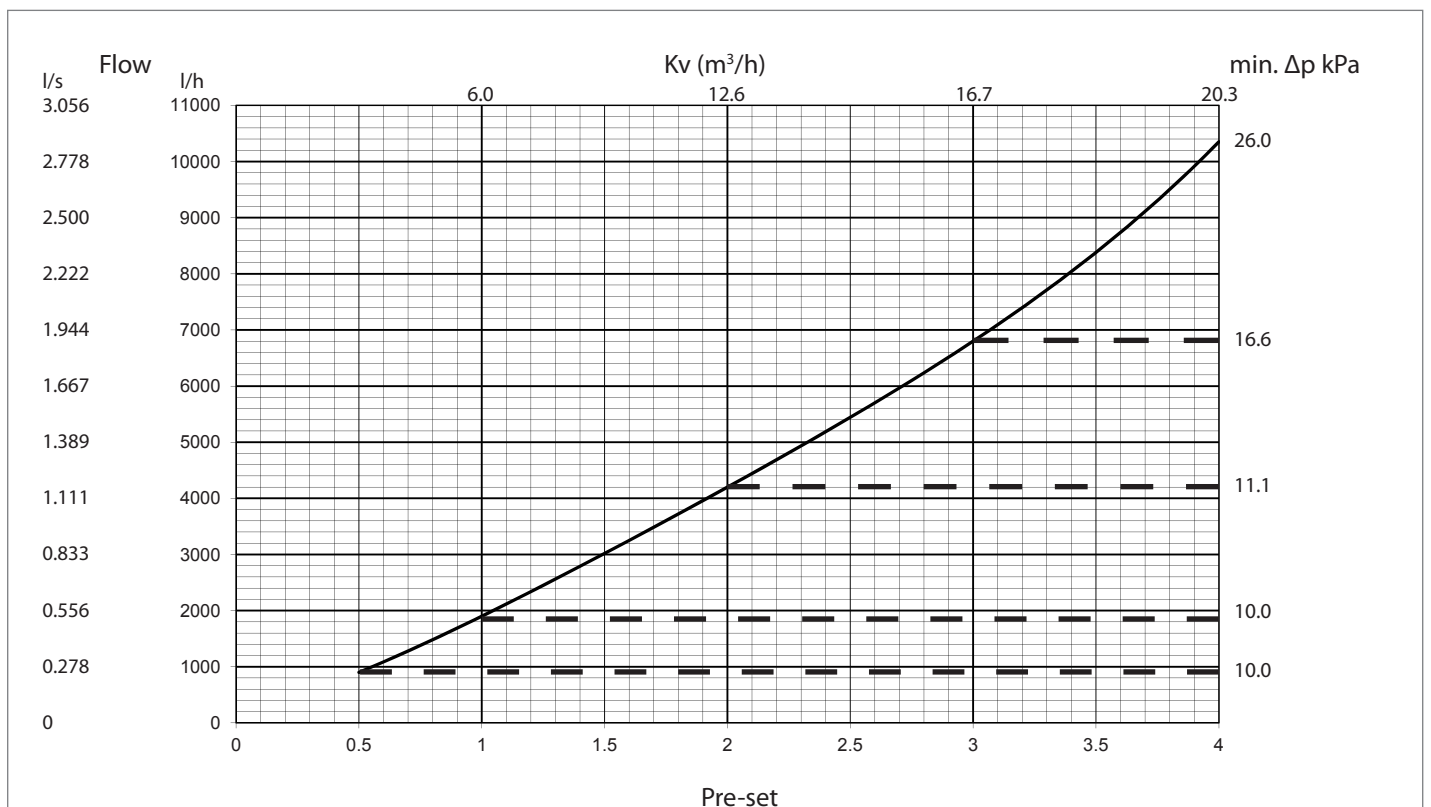

Frese PV-SIGMA Compact Dynamic Pressure and Flow Regulation

Specification Text - Frese PV-SIGMA Compact Dynamic Pressure & Flow Regulation Set

The valve set shall be a combination of a dynamic differential pressure control valve and an externally adjustable dynamic balancing valve

The differential pressure and flow shall be adjustable on site without suspension of operation

The valve set shall limit the flow and differential pressure in a circuit

The valve set shall include P/T plugs for the verification of differential pressure in circuit and across the valve

The valve set shall include a drain on the differential pressure control valve

The differential pressure control valve scale shall only be adjustable by means of a key

The dynamic balancing valve shall be adjusted by means of a lockable handle

The dynamic balancing valve shall be capable of isolation

The valves shall be permanently marked with an indicator for flow direction

The dynamic pressure and flow regulation set shall have a pressure rating of PN25

The maximum differential pressure shall be 400 kPa

The valve housing shall be DZR brass CW602N (DN15 to DN32) and Ductile Iron (DN40 to DN50)

Frese A/S assumes no responsibility for errors, if any, in catalogues, brochures, and other printed matter. Frese A/S reserves the right to modify its products without prior notice, including already ordered products, if this does not alter existing specifications. All registered trademarks in this material are the property of Frese A/S. All rights reserved.

Frese A/S
Sorøvej 8
DK- 4200 Slagelse
Tel: +45 58 56 00 00
Fax: +45 58 56 00 91
info@frese.dk