

Frese OPTIMA Compact

DN50-DN200

- DK** Montagevejledning
- DE** Montageanleitung
- EN** Mounting instructions

Danmark · Tlf. +45 58 56 00 00
 Deutschland · Tel. +49 (0)241 475 82 333
 UK · Tel. +44 (0)1704 896012

- DK** **Produktbeskrivelse:** Frese OPTIMA Compact kombinerer en stilbar dynamisk reguleringsventil med en fuld modulerende kontrolventil. (Se Technote).
- DE** **Produktbeschreibung:** Frese OPTIMA Compact kombiniert einen von aussen justierbaren dynamischen Volumenstromregler mit einem vollmodulierenden Regelventil. (Siehe Technote)
- EN** **Product Description:** Frese OPTIMA Compact combines an externally adjustable dynamic balancing valve with a full authority modulating control valve. (See Technote)

- DE** **Sicherheitsanleitung:** Der Hersteller übernimmt keine Haftung für Schäden, die aus nicht verwendungszweck-bezogener Handhabung resultieren. Diese Risiken liegen ausschliesslich bei dem Anwender. Die Berücksichtigung dieser Montageanleitung ist als Teil des Verwendungszweckes des Ventiles anzusehen.
- EN** **Safety Instructions:** The manufacturer is not liable for any damage resulting from use other than in the designated application. Such risk lies entirely with the user. Observance of the mounting instructions is considered as part of the valve designated use.

FIG 1

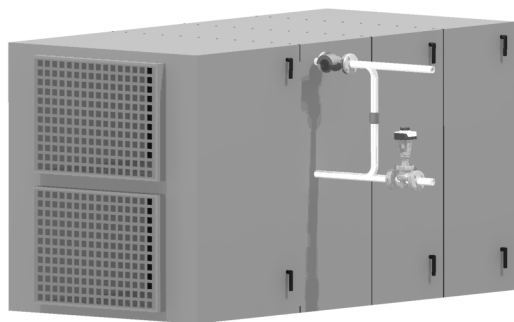

- DK** **FIG 1 Installation:** Frese OPTIMA Compact kan installeres i enten fremløb eller retur. Det anbefales, at man installerer snavssamlere og kuglehænder. Temperaturen i og omkring aktuatoren bør ikke ligge under 0°C.
- DE** **FIG 1 Installation:** Frese OPTIMA Compact wird im Vor- oder Rücklauf montiert. Schmutzfänger und Absperrkugelhähne werden empfohlen. Die Umgebungstemperatur sollte nicht unter 0°C liegen.
- EN** **FIG 1 Installation:** Frese OPTIMA Compact can be mounted in either the supply or the return line. Installation of strainers and isolation ball valves are recommended. The temperature in and about the actuator should not be below 0°C.



- DK** **Sikkerhedsinstruktion:** Fabrikanten forholder sig ikke ansvarlig for nogen form for skade forvoldt ved anden brug end den angivende applikation. Sådanne risici forbeholdes udelukkende brugeren. Det er vigtigt at overholde montagevejledningen for at sikre korrekt anvendelse af ventilen.

FIG 2

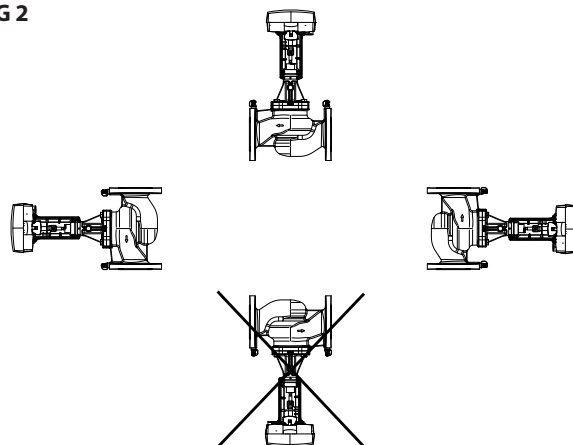

- DK** **FIG 2** Aktuator montageposition
- DE** **FIG 2** Stellantrieb Montageposition
- EN** **FIG 2** Actuator mounting position

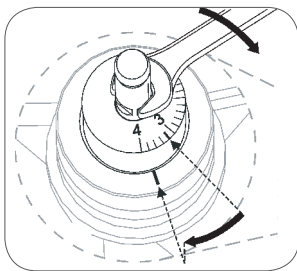

Frese OPTIMA Compact Low Flow DN50

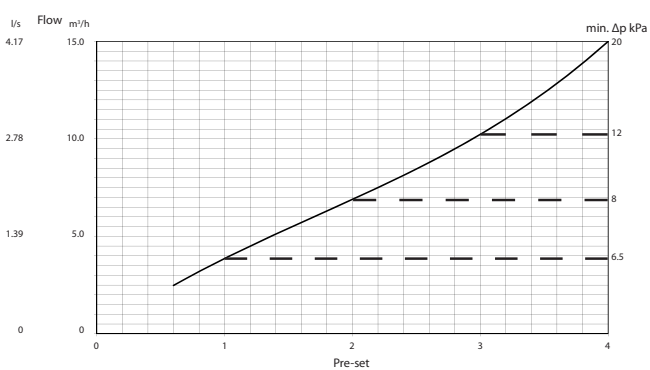

Frese OPTIMA Compact High Flow DN50

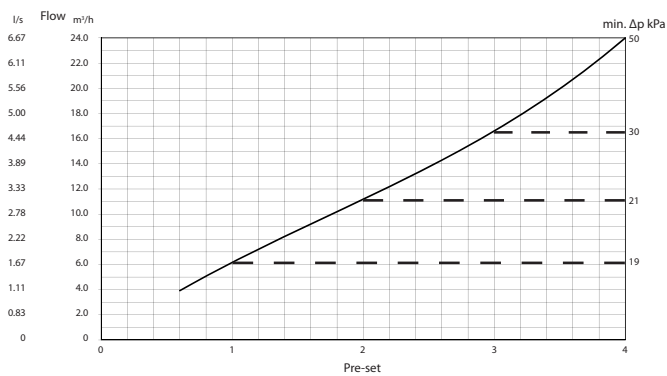

Frese OPTIMA Compact Low Flow DN65

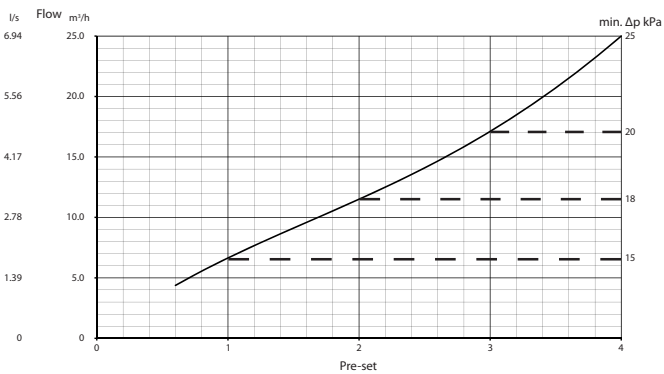

Frese OPTIMA Compact High Flow DN65

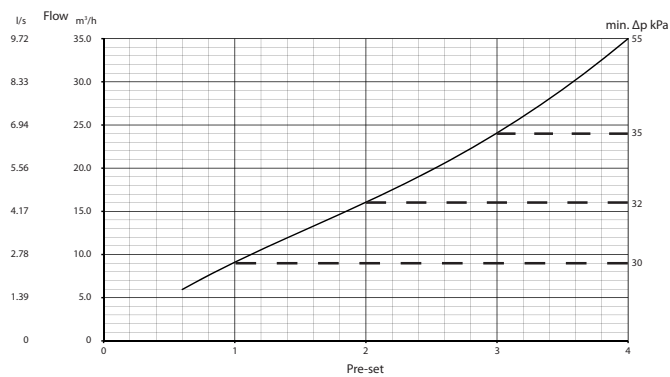

Frese OPTIMA Compact Low Flow DN80

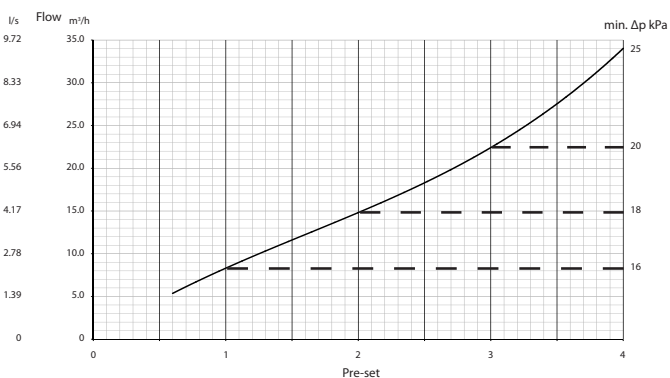

Frese OPTIMA Compact High Flow DN80

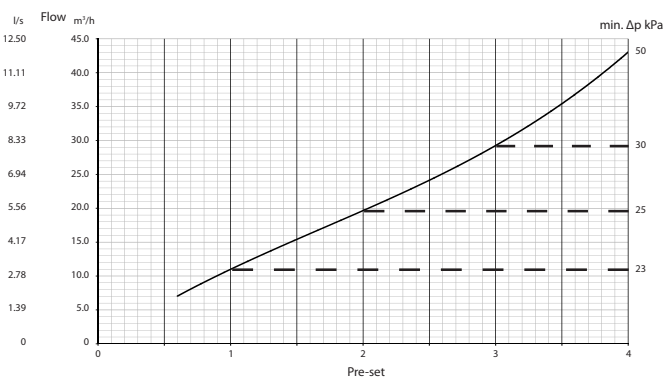

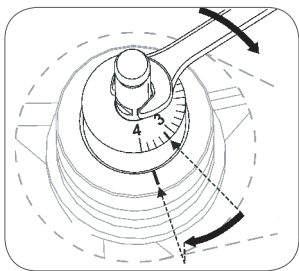

Frese OPTIMA Compact Low Flow DN100

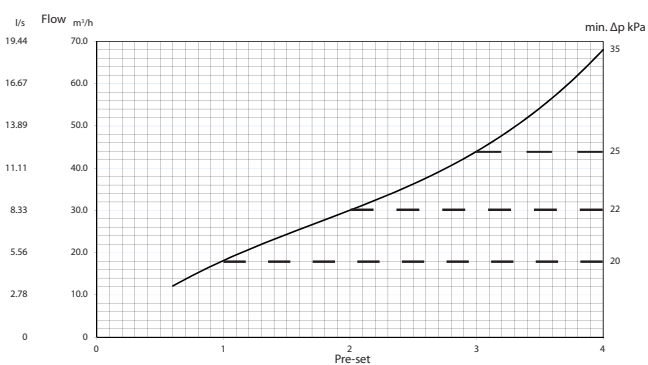

Frese OPTIMA Compact High Flow DN100

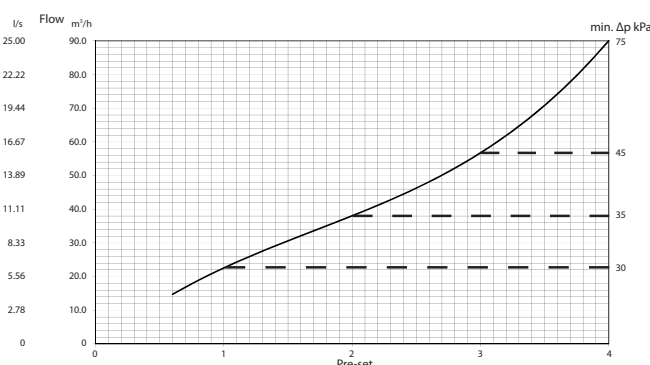

Frese OPTIMA Compact Low Flow DN125

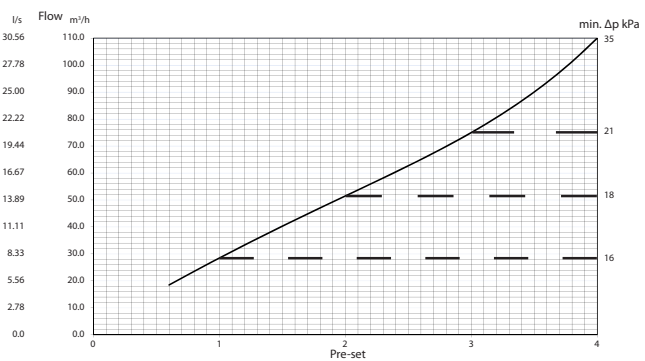

Frese OPTIMA Compact High Flow DN125

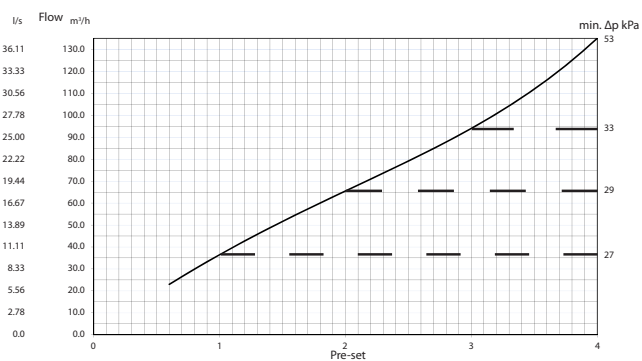

Frese OPTIMA Compact Low Flow DN150

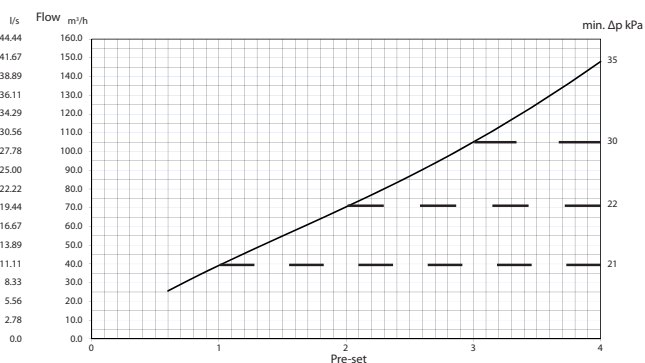

Frese OPTIMA Compact High Flow DN150

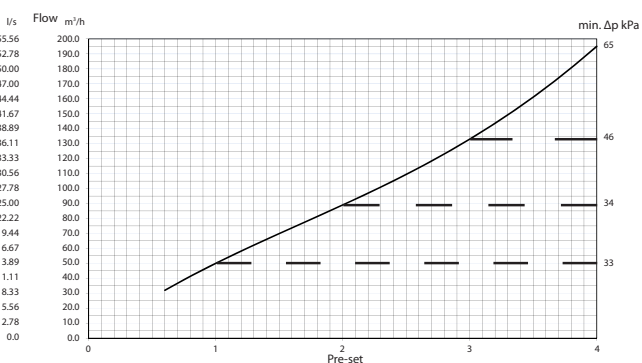

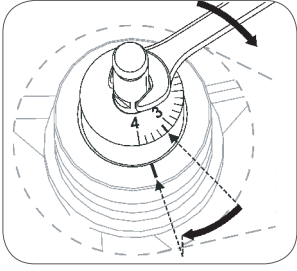

Frese OPTIMA Compact Low Flow DN200

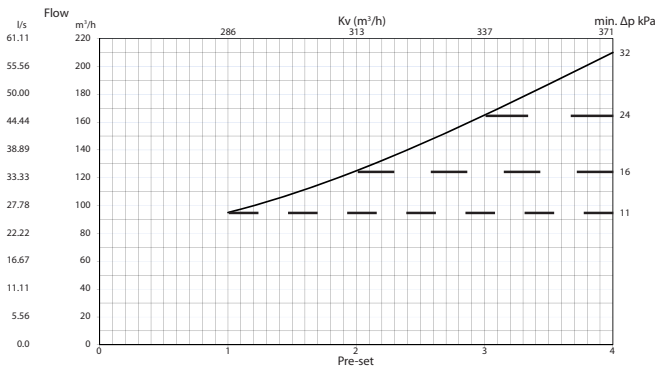

Frese OPTIMA Compact High Flow DN200

