

Frese OPTIMA Compact actuators DN40-DN200

Application

Proportional 0-10V or 3-position modulating control of Frese OPTIMA Compact valves in heating, ventilating and air conditioning systems.

Due to the self adaption of stroke length, the actuator provides full utilization of the OPTIMA Compact valve modulation.

Supplied with the Frese OPTIMA Compact PICV valves (DN40-DN200)



Features

- Self calibrating stroke up to 52 mm
- 3-position or 0-10 V modulating control within the same actuator
- Voltage control signal range can be selected by use of dip switches.
- Linear or EQ% characterization available on the same actuator
- Small outer dimensions
- Removable cable
- Auto zero detection
- Feedback signal
- IP 54 protection
- The electronic circuit of the actuator ensures that the running time is the same, regardless of the stroke of the valve
- Manual operation handle on the actuator

Approvals

- Conforms to: EMC directive 2004/108/EC
- Low voltage directive 2006/95/EC



Frese OPTIMA Compact actuators DN40-DN200

Technical data actuators

Characteristics:	Motoric, modulating, normally closed
Protection class:	IP 54 to EN 60529
Frequency:	50/60 Hz
Control signal:	0-10V DC or 3 position
Control signal impedance:	Min. 100 kOhm (0-10V)
Actuating force:	400 N - DN40-DN50 (Threaded) 800 N - DN50-DN125 (Flanged) 1500 N - DN150-DN200 (Flanged)
Stroke max:	32mm DN40-DN50 (Threaded) 52mm DN50-DN200 (Flanged)
Running time: DN40-DN50	60 s (0-10V) 60 s or 300 s, selectable (3-pos)
Running time: DN50-DN200	30 s (0-10V) 60 s or 300 s, selectable (3-pos)
Ambient operating conditions:	-10°C to 50°C
Manual operation:	Manual handle
Cable:	Not included
Weight:	1.80 kg

Types and Operation Data

Type	Valve Dimension	Function	Supply voltage	Power Consumption
Type-01	DN40-DN50	0-10 V / 3-pos	24 V AC +25%/- 35%	6 VA
Type-02	DN50-125	0-10 V / 3-pos	24 V AC +25%/- 35%	15 VA
Type-03	DN150-200	0-10 V / 3-pos	24 V AC +25%/- 20%	24 VA

Dimensions

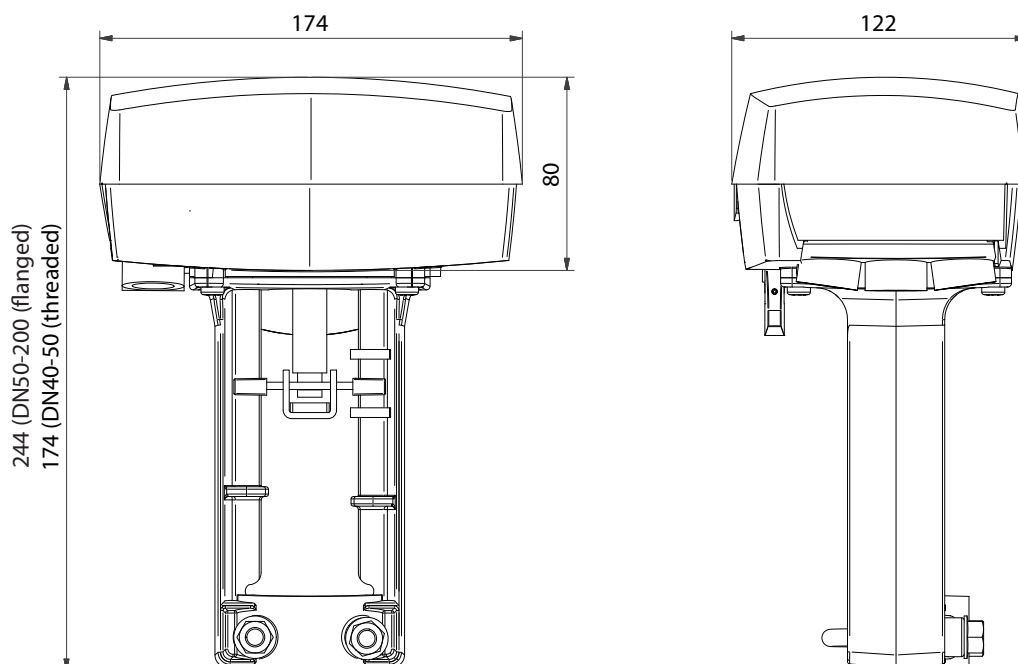

Frese OPTIMA Compact actuators DN40-DN200

Actuator settings

			Function in the		
			"OFF" pos.	"ON" position	Description
IN		OUT	1 Retracts	Extends	Valve closing direction
MOD		INC	2 Modulating	3-pos. floating	Control (not at Sequence)
---		SEQ	3 -	Sequence	Sequence control
0-10		2-10	4 0-10 V	2-10 V	Voltage range
0-5, 2-6		5-10, 6-10	5 0-5 V, 2-6 V	5-10 V, 6-10 V	Part of voltage range
60 s / 0%*		300 s / 50%*	6 60 s, 0% *	300 s, 50% *	Running time (Security function*)
NORM		INV	7 Normal	Inverted	Direction of movement
LIN		EQ%	8 Linear	EQ%	Valve characteristic
OP		ADJ	9 Operation	Calibration	Operation/End position calibration

* DN40-50 actuator versions only

There are nine switches in a row on the circuit board. On delivery ('Factory'), all switches are pre-set as above.

1 Valve Closing Direction — IN / OUT

IN direction of movement is used when the screw of the actuator moves inwards to close the valve. OUT direction of movement is used when the screw of the actuator moves outwards to close the valve.

For OPTIMA Compact valves, ensure this switch is always 'ON'

2 Control signal — MOD / INC

Actuator can either be controlled by a variable direct voltage, known as a modulating signal (MOD), or by a 3-pos. floating signal (INC).

3 Sequence or parallel control — --- / SEQ

With sequence (or parallel) control (SEQ), two actuators/valves can be controlled by only one control signal.

For each of these you can choose which part of the voltage range to use, the upper one, 5-10 V (6-10 V) or the lower one, 0-5 V (2-6 V).

If the switch NORM / INV is in the NORM position, the higher voltage corresponds to 100% flow and the lower one to 0%.

With NORM / INV in the INV position you will get the opposite function.

Note! If sequence or parallel control is not used, the switch --- / SEQ must be in the OFF position, as the switch MOD / INC is not valid during sequence or parallel control.

4 Voltage range — 0-10 / 2-10

You can choose whether to use the control signal voltage range 0-10 V or 2-10 V.

5 Part of voltage range — 0-5, 2-6 / 5-10, 6-10

You can choose which part of a voltage range to use, the lower one 0-5 V (2-6 V) or the upper one 5-10 V (6-10 V).

If the switch is in the NORM position, the higher voltage corresponds to 100% flow and the lower one to 0%. To achieve

the opposite function, the switch should be put in its INV position.

6a Running time — 60 s / 300 s

With 3-point floating control, you can choose a running time between 60 s or 300 s.

With modulating control, the running time is always 15 s / 20 s / 30 s (or 60 s, for DN40-50 actuator versions only).

6b Security function 0% / 50% (DN40-50 actuator versions only)

At 2-10 V control signal you can select which security function you want the actuator to have.

If the actuator is used for heating control and switch 6 is ON (50%), the actuator will open the valve halfway if the control signal disappears, e.g. if the X1 connection is unplugged.

If, instead, you want the valve closed, set switch 6 to OFF (0%).

Note! The direction of movement is also significant. See the following description.

7 Direction of movement — NORM / INV

Actuators direction of movement according to the control signal. In normal 'NORM' mode the actuator directly follows the control signal and closes the valve downwards against a 0V control signal.

In inverse 'INV' mode, the actuator reverses the direction of travel against the control signal and will open the valve upwards against a 0V control signal.

8 Linearization — LIN / EQ%

The total valve characteristics can be modified from linear to EQ%.

9 End position adjustment — OP / ADJ

This switch is only used to calibrate the end positions when the actuator is commissioned. Momentarily put the switch in the ON position. The actuator will automatically find the end positions of the valve. For normal operation the switch must be OFF

Frese OPTIMA Compact actuators DN40-DN200

Connection diagrams

G, G0 = Max 100 m 1.5 mm² (AWG 15)
 X1, MX, Y, VH, VC = Max 200 m 0,5 mm² (AWG 20)

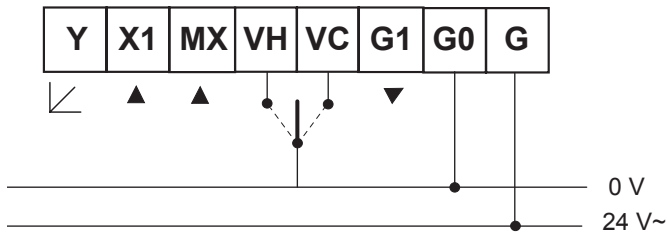

Block	Function	Description
G	24 V AC	Supply voltage
G0	24 V AC return	
X1	Input	Control signals (VH, VC short-circuited to G0)
MX	Input, neutral	
VH	Increase	
VC	Decrease	
G1	16±0.3 VDC, 25 mA	Short circuit-safe supply
Y	0-100% (2-10V)	
		Feedback signal

Wiring examples

0-10V, 2-10V..... control signal

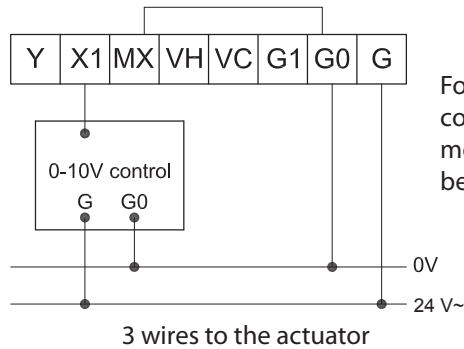
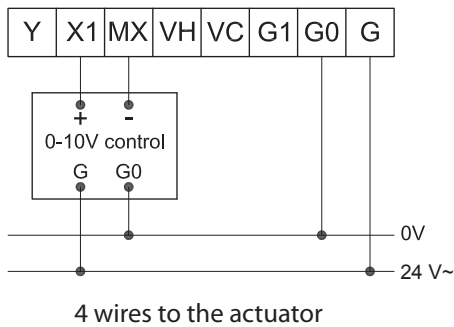

For 0-10V control with 3 wire connection, it is needed to mount an internal wiring between MX and G0

3-pos control signal

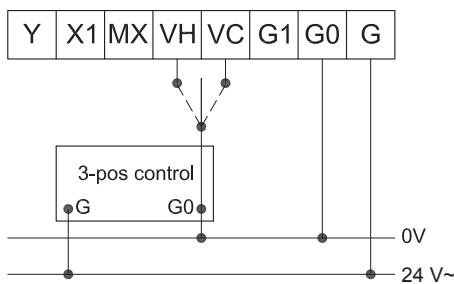

4-20 mA control signal

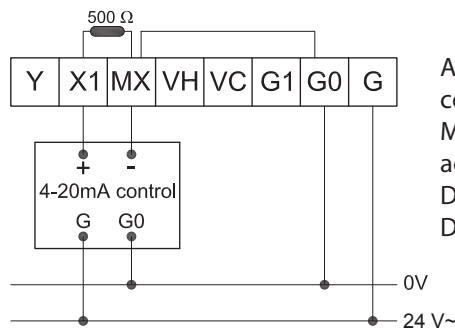

A 500 Ω resistor must be connected between X1 and MX. (Not delivered with the actuator)
 Dip switch 2 must be OFF and Dip switch 4 must be ON

Frese A/S assumes no responsibility for errors, if any, in catalogues, brochures, and other printed matter. Frese A/S reserves the right to modify its products without prior notice, including already ordered products, if this does not alter existing specifications. All registered trademarks in this material are the property of Frese A/S. All rights reserved.