

Frese DELTA T Control System

Description

The Frese DELTA T Control System is an easy-to-use solution for measuring, monitoring and optimizing the ΔT between the inlet and outlet of a terminal unit, in order to increase the system efficiency and reduce pump energy.

Operation

The DELTA T Control System measures and monitors the actual ΔT of the coil.

If the ΔT is equal to or higher than the ΔT set point, the Frese DELTA T Control System will not change the input signal to the actuator and the flow will be according to the BMS input signal.

If the ΔT is lower than the ΔT set point, the Frese DELTA T Control System will lower the input signal to the actuator and thereby decrease the flow through the control valve until the set point ΔT is reached.

Application

The Frese DELTA T Control System can be used in both heating and cooling systems to optimise the inlet and outlet temperature difference of a fan coil unit or air handling unit.

Benefits

- Energy saving through the control of ΔT in the system.
- Provides optimal efficiency for chillers and boilers.
- By reducing the required flow to achieve the system ΔT , additional flow capacity can be released.
- Simple installation between the BMS and the 0-10VDC modulating actuator.
- Quick and simple to set up.
- Can be easily retrofitted to an existing system.



Features

- Easy to use buttons for setting the optimum ΔT set point.
- Automatically detects whether the Control System is installed in a heating or cooling system.
- Temperature sensors can be mounted on a variety of pipe dimensions from DN15 to DN300.
- To avoid starving the coil of flow the DELTA T Control System is programmed so it never sends a voltage signal to the actuator of less than 1.5 V. This means that the DELTA T Control System does not close the valve fully even if the measured ΔT is below the set point. The BMS can always close the valve if the signal sent is less than 1.5V.
- 0-10 V DC feedback signal for monitoring the terminal unit operation.

Frese DELTA T Control System

The Importance of Achieving Design ΔT

Achieving design ΔT is critical for overall system efficiency and particularly for plant room performance.

To ensure the return temperature from the secondary side to the primary side of the building is as designed (and therefore the ΔT is as designed), the energy transfer at the coils on the secondary side must be achieved. Consequently, coil performance is important to achieving design ΔT and overall system efficiency.

Coils perform at their most efficient point when the temperature difference (ΔT) between the flow and return water to and from the coil is at the design ΔT of the coil (published by the coil manufacturer).

- Increasing ΔT means a decrease in required flow rate for a given load.
- A decrease in flow rate means a major decrease in pump energy consumption.

Function of the Frese DELTA T Control System

The main function of the Frese DELTA T Control System is to measure and monitor the actual ΔT of a coil and ensure that the actual ΔT will never be lower than the ΔT set point.

When the water flow through a terminal unit exceeds the flow at which the energy from the water can be efficiently transferred to the building, the Power Saturation Point* of the coil is exceeded and the ΔT drops below the design value for that terminal unit. This is overflowing the coil.

Overflowing the coil consumes extra pump energy and lowers the efficiency of the chillers or boilers. To avoid overflowing the coil, the Frese DELTA T Control System reduces the flow through the control valve and coil, thereby increasing the ΔT of the coil until it is restored to the set point value.

* Power Saturation Point of the coil - the point beyond which the coil cannot produce additional power transfer regardless of increased flow

Setting the Optimum ΔT using the Frese DELTA T Control System

The Frese DELTA T Control System runs with a standard (default) ΔT of 5.5 °C.

Every coil has a design ΔT which is given in the data sheet for the relevant coil.

If required, the default ΔT setting of the DELTA T Control Unit can be manually overridden and set to the design value.

To set ΔT , press and hold the OK button **(2)** for minimum one second. The set point ΔT value is changed by the buttons **(1)** and confirmed by the OK button **(2)**

The display **(3)** will change between the actual ΔT value and the set point ΔT value. When the set point ΔT is shown in the display, the green LED **(4)** will be on.

The controller auto-detects and indicates with the red or blue LED **(5)** whether it operates in heating or cooling systems.



Frese DELTA T Control Unit

Frese DELTA T Control System

Installing the Frese DELTA T Control System

The Frese DELTA T Control System offers installation flexibility. Can be retrofitted to existing systems with ease and minimal disruption, or installed directly into new systems.

The example below shows the Frese DELTA T Control System installed on a terminal unit with the Frese OPTIMA Compact pressure independent control valve.

Please note:

- Insulation can be placed over the temperature sensors.
- Temperature sensor cables must be the same length.
- Temperature sensors must be a similar distance from the coil and as close as possible.

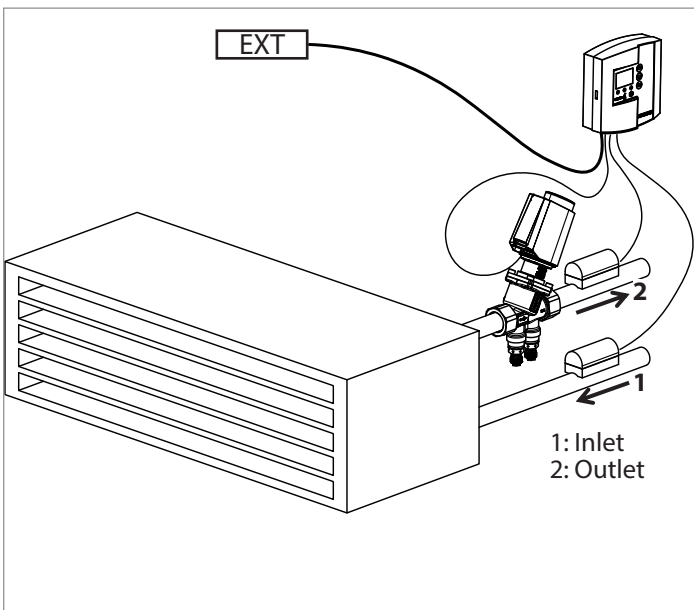

Frese DELTA T Control System mounting

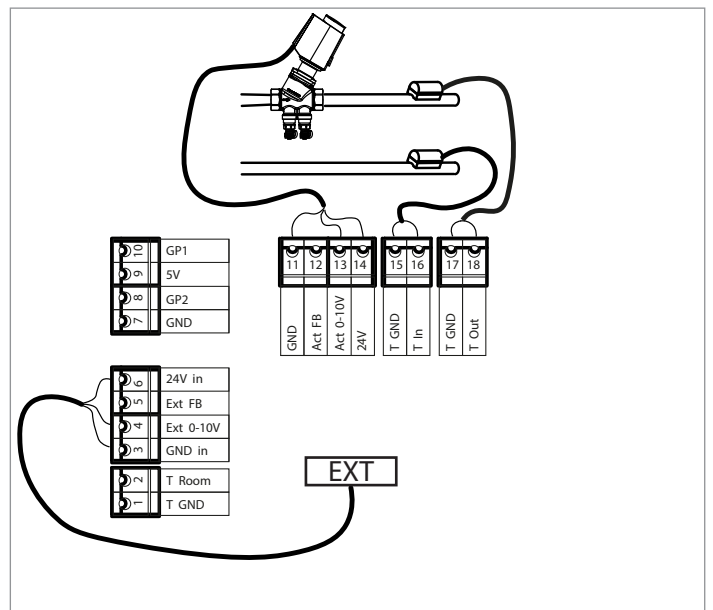

Frese DELTA T Control System electrical wiring

The Frese DELTA T Control Unit can be mounted on a DIN rail using the DIN rail clips or directly on the wall.

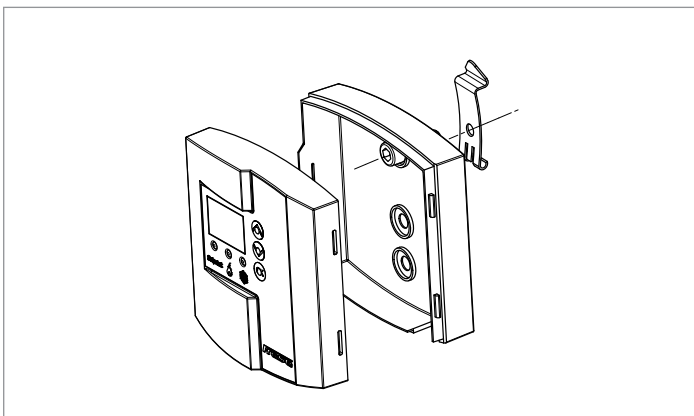

Frese DELTA T Control Unit mounted with DIN rail mounting clips

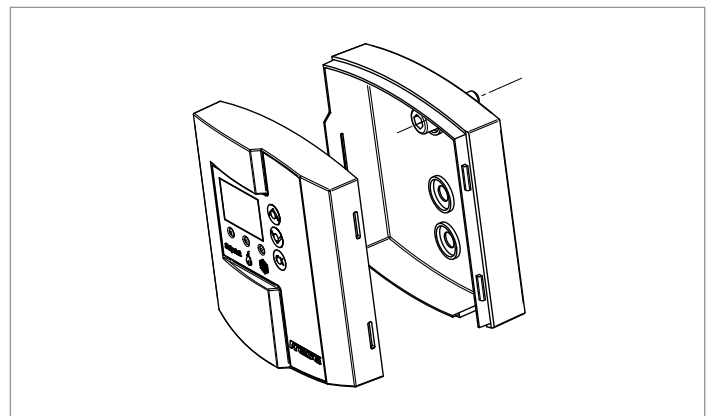

Frese DELTA T Control Unit mounted on a wall

Frese DELTA T Control System

Technical Data

Control unit material:	ABS and Polycarbonate
Temperature sensor material:	ABS
Protection class:	IP 24 to EN 60529
Supply:	24V AC/DC
Power consumption:	1,5 VA
Maximum power consumption:	4 VA
Control input/output signal:	0 - 10V DC
Feedback signal:	0-10V DC
ΔT setting range:	0.2°C - 40°C
Temperatur sensor range:	0°C - 110°C
Ambient operating conditions:	5°C - 50°C 20 - 90% RH
Weight:	110 g
Cable length - temperature sensor:	2 m

Dimensions [mm]

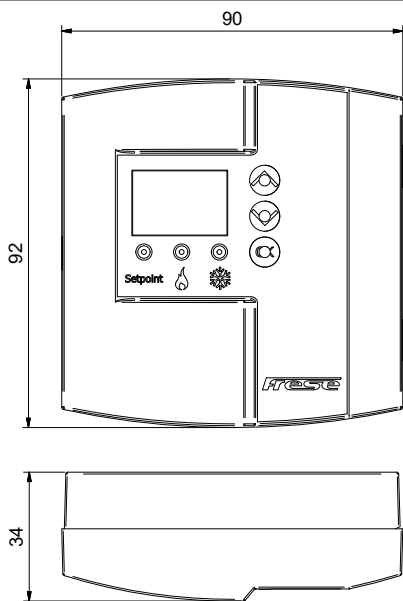

Frese DELTA T Control Unit

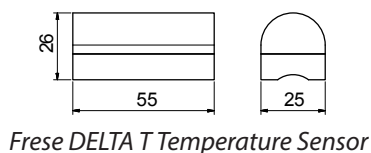

Frese DELTA T Temperature Sensor

Product Programme Frese DELTA T Control System

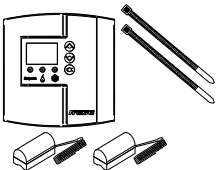
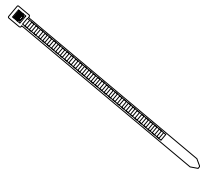
	Type	Frese no.
	Frese DELTA T Control System including temperature sensors with 2 m cable, and cable ties for pipe dimensions up to DN65	48-5548
	Cable ties 600mm (4 pcs)	07-2823

Frese DELTA T Control System

Technical Specification Text

- The DELTA T Control System shall be able to control both heating and cooling applications
- The DELTA T Control Unit shall automatically detect if mounted in a heating or a cooling application and indicate this by means of LED lights
- The DELTA T Control Unit shall, by an LED display, show the set point ΔT and the actual ΔT
- Design ΔT shall be set with steps of 0.1°C
- The DELTA T Control System shall consist of 1 DELTA T Control Unit and 2 temperature sensors with 2 m cables
- Feedback signal 0-10V
- The temperature sensors shall be mounted on the pipes without intrusion of, or modification to, the pipes

Frese A/S assumes no responsibility for errors, if any, in catalogues, brochures, and other printed matter. Frese A/S reserves the right to modify its products without prior notice, including already ordered products, if this does not alter existing specifications. All registered trademarks in this material are the property of Frese A/S. All rights reserved.

Frese A/S
Sorøvej 8
DK- 4200 Slagelse
Tel: +45 58 56 00 00
Fax: +45 58 56 00 91
info@frese.dk

