

Frese OPTIMIZER 6-way Pressure Independent Control Group

Description

The Frese OPTIMIZER 6-way Pressure Independent Control Group provides complete pressure independent balancing and control for 4-pipe heating and cooling systems.

Operation

The Frese OPTIMIZER 6-way provides modulating control, which works independently of any variations in the differential pressure of the system.

The group consists of an OPTIMA Compact pressure independent control valve (PICV) with a 0-10V modulating actuator, a 6-way control valve with a rotating actuator and the Control Unit.

Application

The Frese OPTIMIZER 6-way can be used in 4-pipe systems, such as:

- Heating and cooling ceilings
- Convectors
- Decentralised ventilation units
- Fan coil systems
- Convection heating & cooling units

Benefits

- Only one data point for the BMS needed
- Complete solution. No balancing valves required in the system
- Energy saving through optimum pressure independent flow limitation and regulation
- Modulating control for both cooling and heating
- Less time spent in selection and sizing. Only design flow and minimum differential pressure required
- Full comfort without recommissioning should the system be extended during the construction phase
- Compact solution with small space requirements
- Silent operation when modulating heating and cooling
- Stand alone or central room temperature control
- No time consuming commissioning required
- Safety function closes the modulating valve if the external input signal is lost



Features

- The pre-setting function of the PICV has no impact on the stroke - full stroke modulation at all times, regardless of the pre-set flow
- The constant differential pressure across the modulating control component of the PICV guarantees 100% authority
- Dynamic balancing eliminates overflows, regardless of fluctuating pressure conditions in the system
- Motoric on/off actuator for the 6-way valve and thermic 0-10V modulating actuator for the PICV
- Achieves high flows with minimal required differential pressure due to advanced design of the PICV
- Higher pre-setting precision due to stepless analogue scale of the PICV
- Ultra-high KVS value on the 6-way valve to provide minimal pressure loss
- Automatic exercising of 6-way valve once a week
- Control unit with 0-10 V DC feedback signal for modulating valve opening
- ΔT control for optimal energy transfer, can be supplied as an accessory.
- To avoid condensation in the system a dew point sensor can be connected to the control unit.

Frese OPTIMIZER 6-way Pressure Independent Control Group

Function

The Frese OPTIMIZER 6-way controls both heating and cooling with only one single data point from the BMS system, through a 0 -10V external input signal.

Full modulation is provided at all times even with different design flows for heating and cooling.

The design flow rate for the cooling system defines the maximum flow through the coil and it is set using the Pressure Independent Control Valve, Frese OPTIMA Compact (see page 8 and 9).

The Frese OPTIMIZER 6-way Control Unit allows the setting of hot water maximum flow, from 100% down to 10% of the maximum cooling flow.

The heat offset flow can be set using the buttons on the Frese OPTIMIZER 6-way Control Unit.

Frese OPTIMIZER 6-way may be also provided with Frese DELTA T control system functionality. For this purpose the temperature sensors which are offered as an accessory should be connected to the control unit.

The Frese DELTA T Control System is an easy-to-use solution for measuring, monitoring and optimizing the ΔT between the inlet and outlet of a terminal unit, in order to increase the system efficiency and reduce pump energy consumption.

To avoid condensation in the system a dew point sensor can be connected to the control unit.

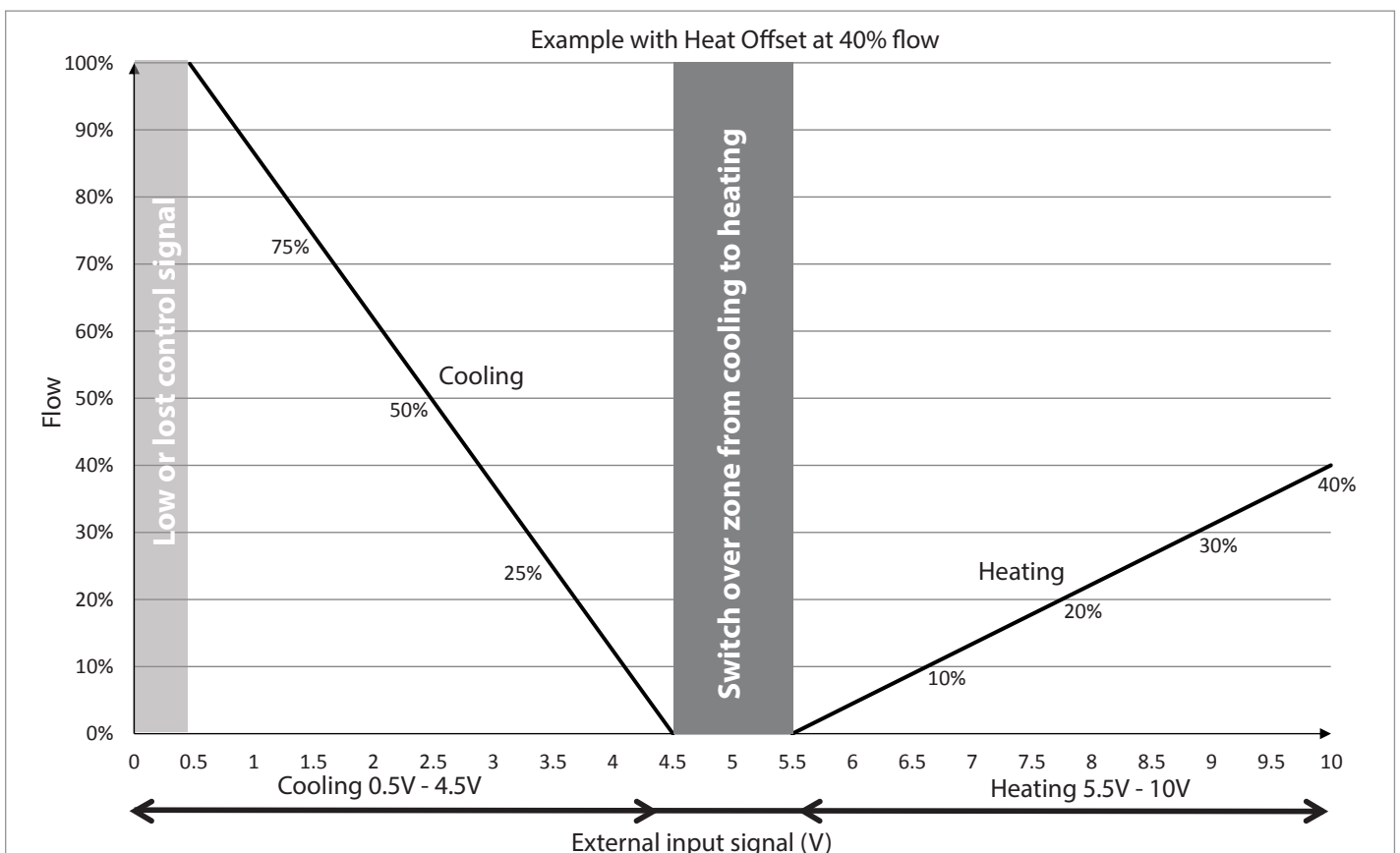
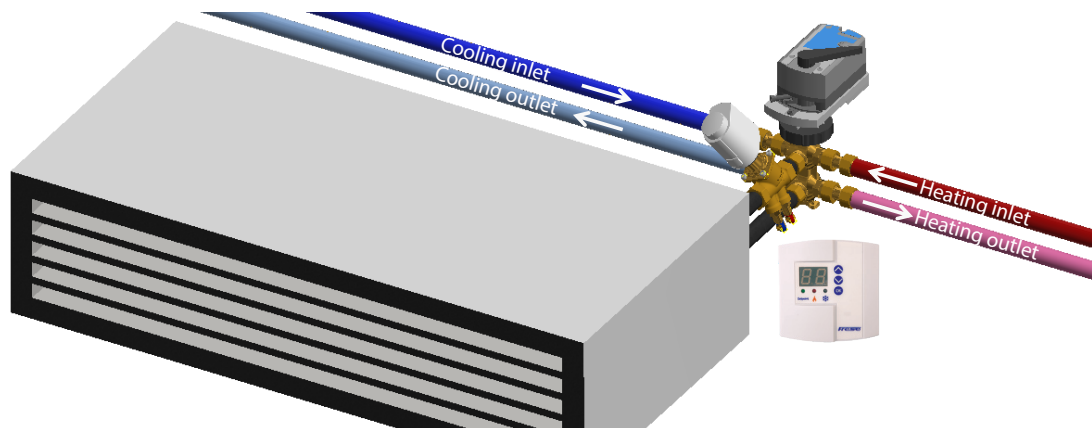

Frese OPTIMIZER 6-way Pressure Independent Control Group

Operation

The design flow for cooling will normally be higher than the design flow for heating due to lower ΔT and thereby defines the maximum flow rate required through the coil.

The maximum flow rate required is set using the Optima Compact PICV (see page 8-9).

The design flow for heating is set as a percentage (10 – 100%) of the design flow for cooling.

During the switch over time (External input signal 4.5V–5.5V) the Frese Optima Compact remains closed until the switching of the 6-way valve has been safely completed.

The switch over condition is signaled by the simultaneous flashing of the red & blue LEDs (**2+3**) on the Frese Optimizer 6-Way control unit.

Example: Setup without ΔT control

Example:

Design flow, cooling: 600 l/h
Design flow, heating: 180 l/h (flow % = **30**)

Control unit setup:

Press the OK-button (**1**)
The red LED (**2**) for heating is lit and the display is blinking. Set the percentage for heating to **30** using the UP and DOWN buttons (**5**). Press OK-button (**1**) to confirm.



Example: Setup with ΔT control

Frese Optimizer control unit automatically detects when the temperature sensors are connected. Once this has been done the control unit switches to Frese Optimizer 6-way with Frese Delta T control system mode.

Example:

Design flow, cooling: 600 l/h
Design flow, heating: 180 l/h (flow % = **30**)

Design temperatures:

Cooling: 7°C - 12°C ($\Delta T = 5^{\circ}\text{C}$)
Heating: 60°C - 30°C ($\Delta T = 30^{\circ}\text{C}$)

Control unit setup:

Press the OK-button (**1**)
The red LED (**2**) for heating is lit and the display is blinking. Set the ΔT for heating to **30** using the UP and DOWN (**5**) buttons. Press OK-button (**1**) to confirm
The blue LED (**3**) for cooling is lit and the display is blinking. Set the ΔT for cooling to **5** using the UP and DOWN buttons (**5**). Press OK-button (**1**) to confirm.
The green LED (**4**) for setpoint is lit and the display is blinking. Set the percentage for heating to **30** using the UP and DOWN buttons (**5**). Press OK-button (**1**) to confirm.

Example: Valve selection and pump head calculation

Design flow, cooling: 600 l/h
Design flow, heating: 180 l/h
Pipe size: DN15

Head loss required for the 6-way valve:

$$\Delta p = (Q/kv)^2$$

$$\Rightarrow \Delta p = (0.6/1.9)^2$$

$$\Rightarrow \Delta p = 0.099 \text{ bar (9.9 kPa)}$$

Valve selection is determined by the maximum flow required through the coil (i.e. 600 l/h).

Total pump head required:

$$\Delta p = 18.7 \text{ kPa} + 9.9 \text{ kPa} = \mathbf{28.6 \text{ kPa}} \text{ (at 600 l/h)}$$

In this case the Frese Optimizer 6 way, product code 53-1847 is chosen. (See page 10)

Easy selection by use of Quickcalc available for download at www.frese.eu

By use of the flow graph page 8 the pre-setting and min. Δp for the Frese Optima PICV (220-1330 l/h) can be determined:

Max. flow required: 600 l/h
Pre-set: 1.8
Min. Δp : 18.7 kPa

Frese OPTIMIZER 6-way Pressure Independent Control Group

Technical Data - Frese OPTIMA Compact PICV

Valve housing:	DZR Brass, CW602N
DP controller:	PPS 40% glass
Spring:	Stainless steel
Diaphragm:	HNBR
O-rings:	EPDM
Pressure class:	PN25
Max. differential pressure:	800 kPa
Medium temperature range:	0°C to 120°C



Technical Data - Frese Thermic Actuator for PICV

Characteristics:	Thermic actuator, normally closed
Protection class:	IP 54 to EN 60529
Supply:	24V AC
Frequency:	50/60 Hz
Control signal:	0-10V DC
Actuating force:	100 N
Stroke:	max. 5.5 mm
Running time:	30 s/mm, 0-10 V DC
Ambient operating conditions:	0°C to 60°C
Cable length:	1.0 m



Technical Data - Frese 6-way Valve

Valve housing:	DZR Brass, CW602N
Sealings:	PTFE
Pressure class:	PN16
Medium temperature range:	0°C to 90°C
Kvs (DN15 total valve):	1.9
Kvs (DN20 total valve):	4.25
Kvs (DN25 total valve):	4.25
Couplings:	DZR Brass CW602N



Technical Data - Frese Rotating Actuator for 6-way Valve

Characteristics:	Motoric rotating actuator
Protection class:	IP 54 to EN 60529
Supply:	24V AC/DC
Frequency:	50/60 Hz
Control signal:	3-point on/off
Actuating moment:	5 Nm
Running time:	150 s, 90°
Ambient operating conditions:	-20° to 50° C
Cable length:	0.9 m

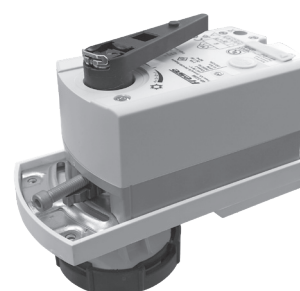

Frese OPTIMIZER 6-way Pressure Independent Control Group

Technical Data - Control Unit

- Material control unit housing:** ABS/PC
- Protection class:** IP 23 to EN 60529
- Supply:** 24V AC/DC
- Power consumption** Max 4 VA (total group)
- Control signal:** 0-10V DC
- Ambient operating conditions:** 0°C to 50°C, 20-90% RH



Frese DELTA T sensor (accessory)

- Material sensor housing:** ABS
- Cable type:** Silicon -40°C to 180°C
- Cable length:** 2 m

Installation & Electrical wiring

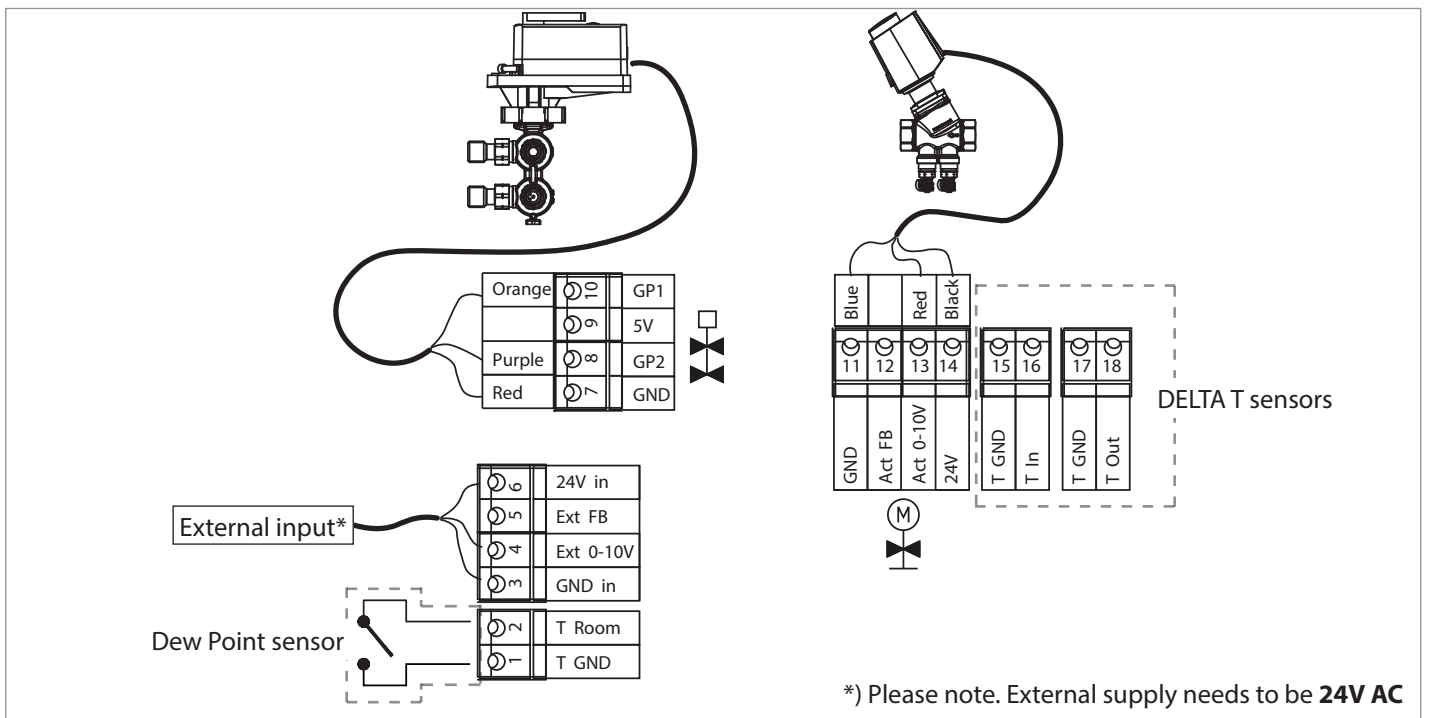
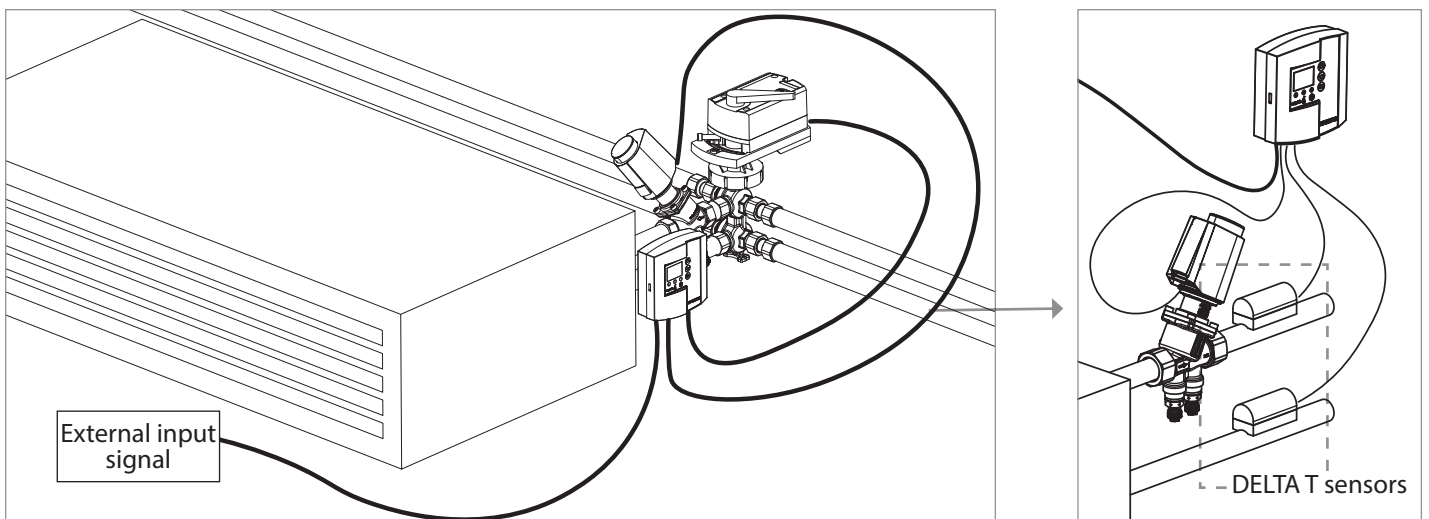

Frese OPTIMIZER 6-way Pressure Independent Control Group

Mounting of Control Unit

The Frese OPTIMIZER 6-way Control Unit can be mounted to either a pipe using the pipe connectors, a DIN rail using the DIN rail clips, or directly on the wall.

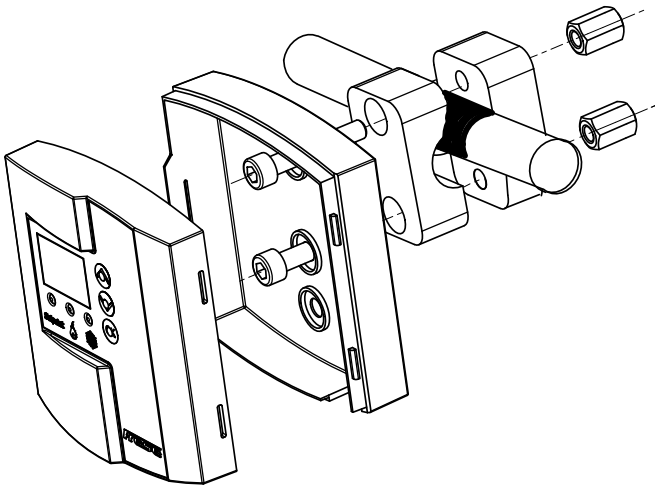

Frese OPTIMIZER 6-way Control Unit mounted with pipe connector on a pipe

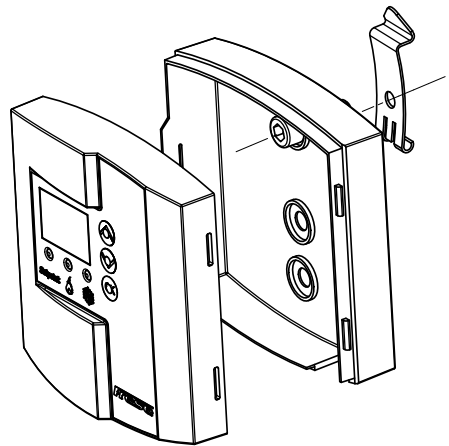

Frese OPTIMIZER 6-way Control Unit mounted with DIN rail mounting clips

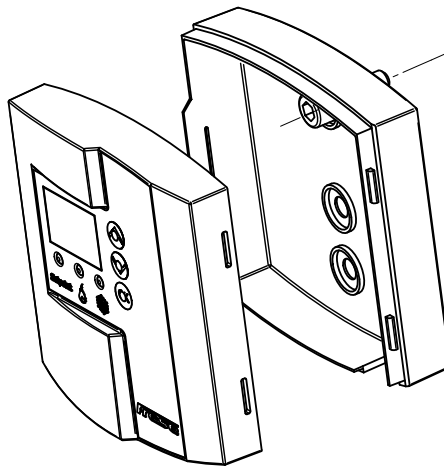

Frese OPTIMIZER 6-way Control Unit mounted on a wall

Frese OPTIMIZER 6-way Pressure Independent Control Group

Dimensions

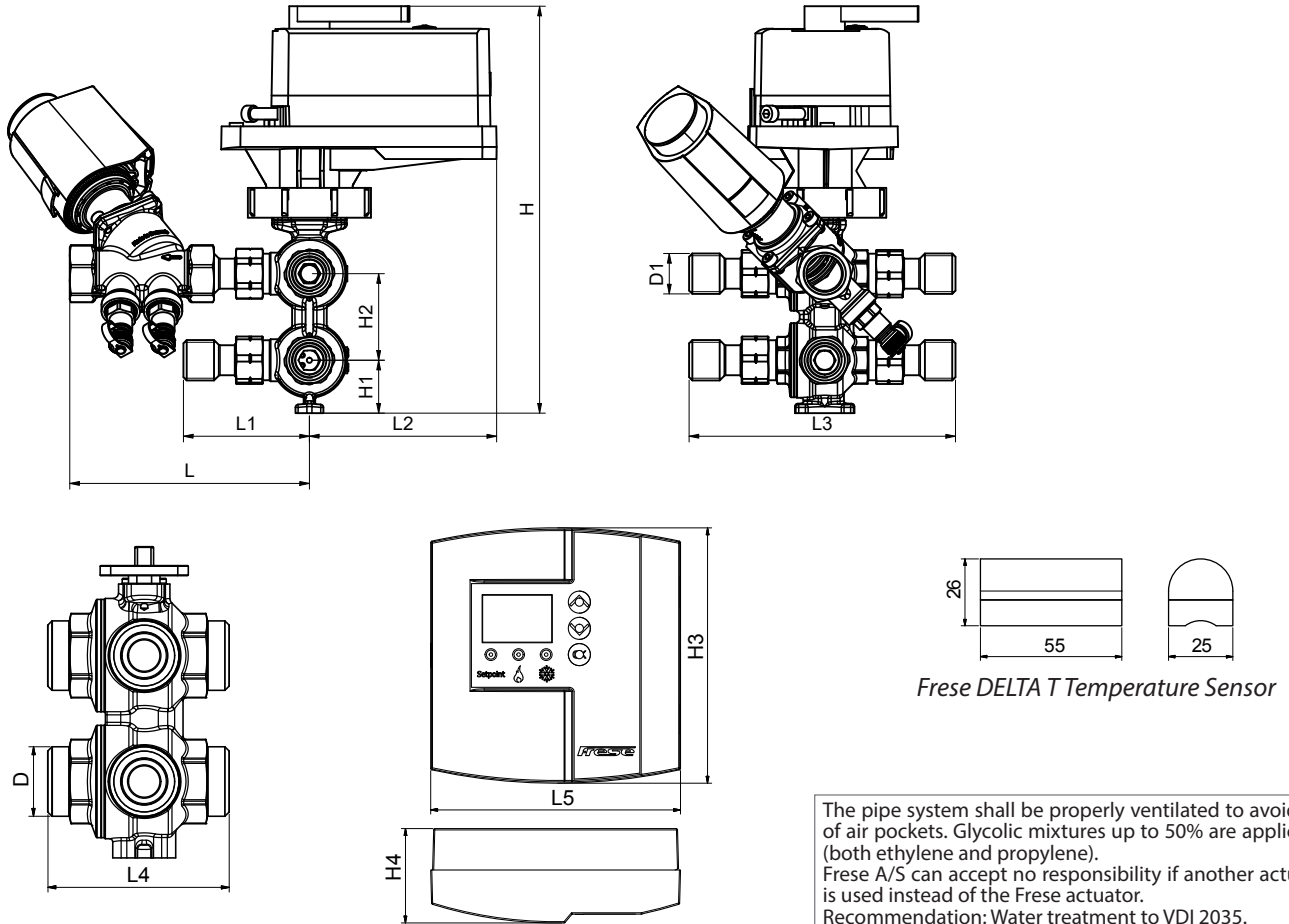

The pipe system shall be properly ventilated to avoid risk of air pockets. Glycolic mixtures up to 50% are applicable (both ethylene and propylene). Frese A/S can accept no responsibility if another actuator is used instead of the Frese actuator. Recommendation: Water treatment to VDI 2035.

Dimension Table

Size		DN15	DN20	DN25
Length mm	L	135	138	167
	L1	69	69	70
	L2	97	97	97
	L3	147	145	161
	L4*	68	87	87
	L5	90	90	90
Height mm	H	212	243	243
	H1	27	36	36
	H2	45	60	60
	H3	92	92	92
	H4	35	35	35
Thread	D*	M/M G 1/2	M/M G 1	M/M G 1
	D1	M/M G 1/2	M/M G 3/4	M/M G 1
	D2	F/F G 1/2	F/F G 3/4	F/F G 1

*) Dimensions without Couplings

Frese OPTIMIZER 6-way Pressure Independent Control Group

Frese OPTIMA Compact PICV Low 5.0 DN15 (65-370 l/h)

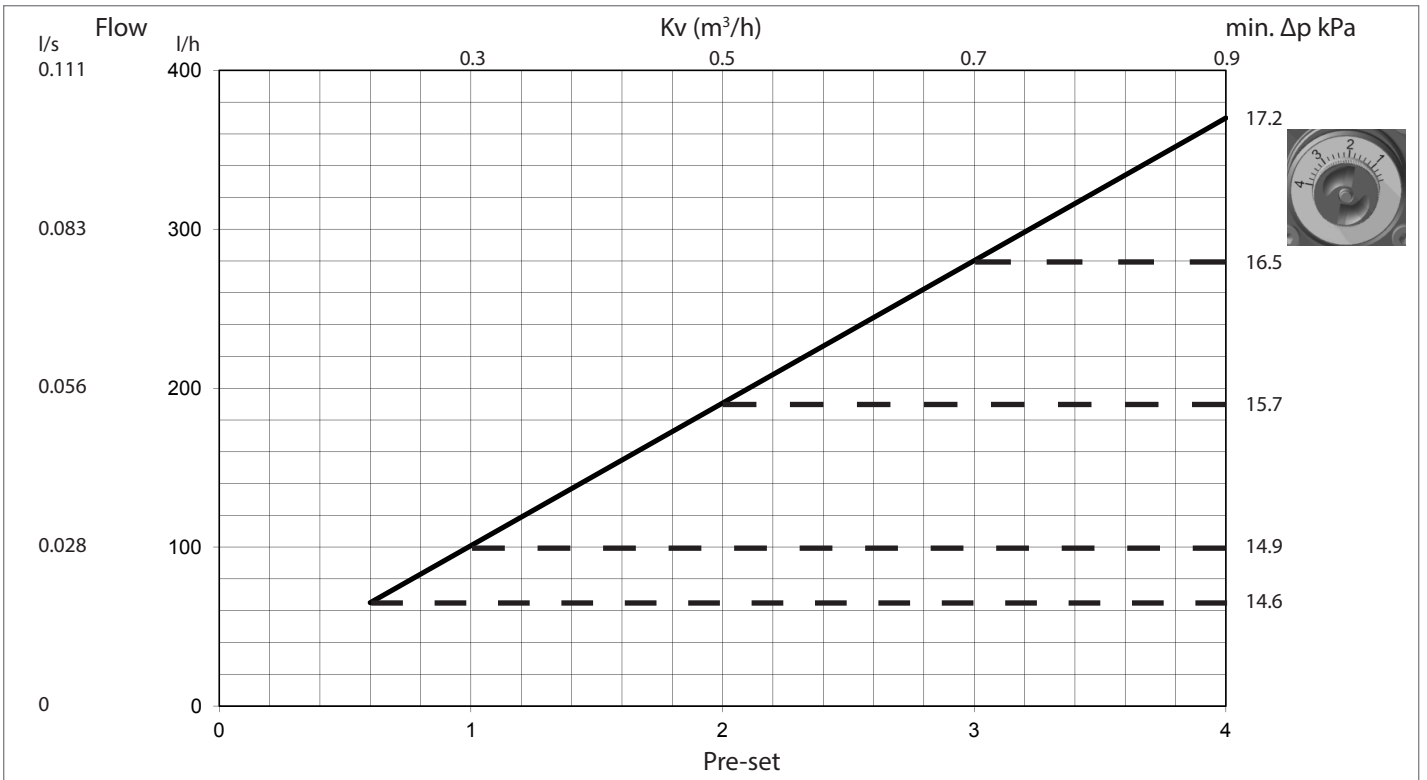

Frese OPTIMA Compact PICV High 5.0 DN15 (220-1330 l/h)

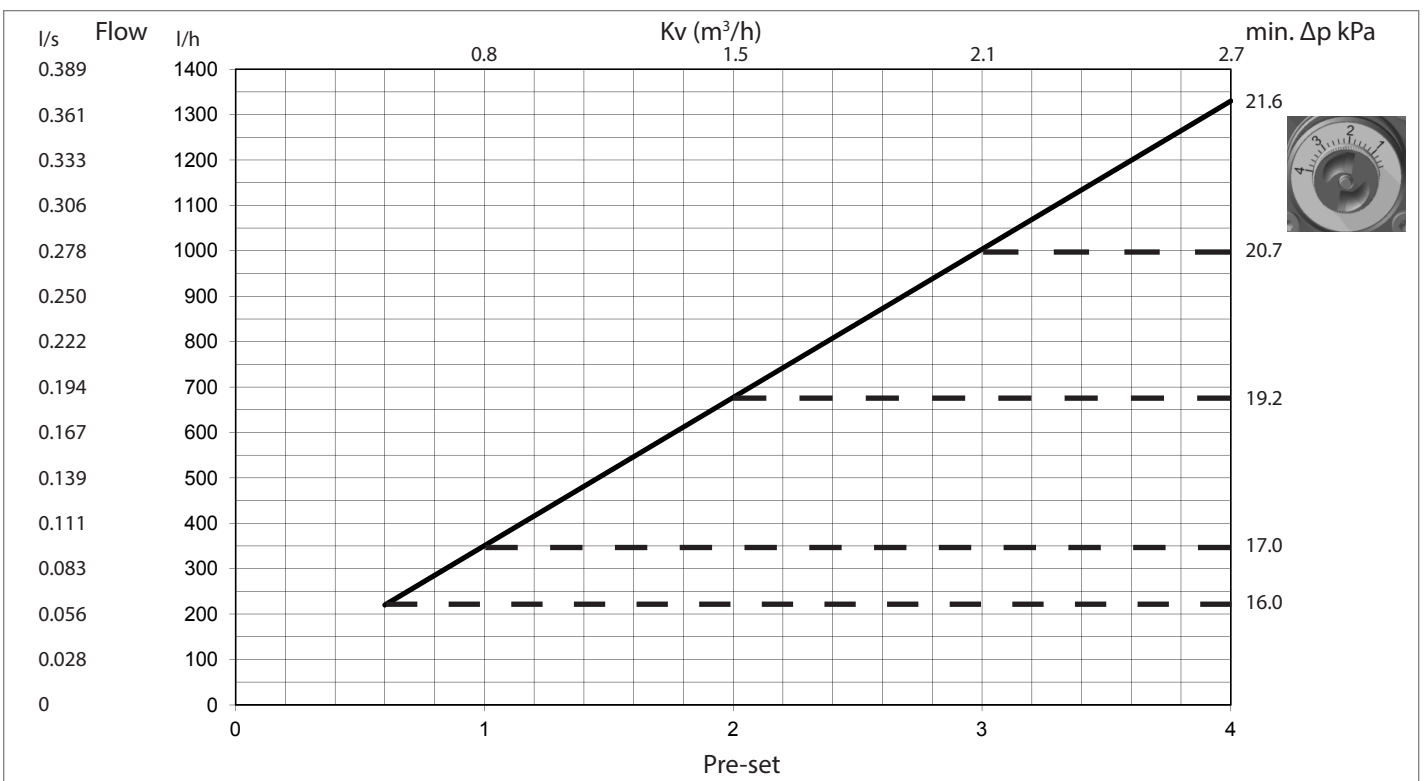

For further details: See OPTIMA Compact PICV Technote

Frese OPTIMIZER 6-way Pressure Independent Control Group

Frese OPTIMA Compact PICV High 5.5 DN20 (300-1800 l/h)

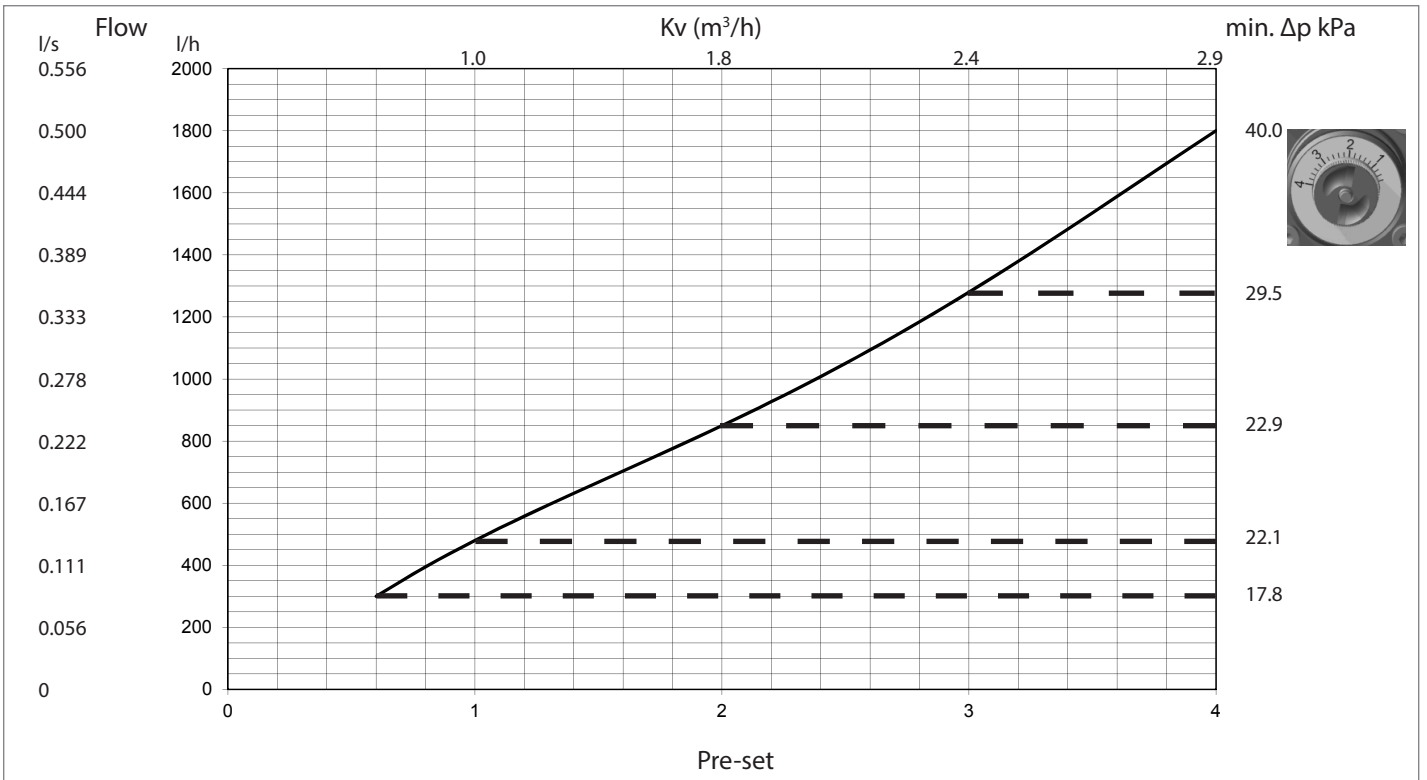

Frese OPTIMA Compact PICV High 5.5 DN25L (600-3609 l/h)

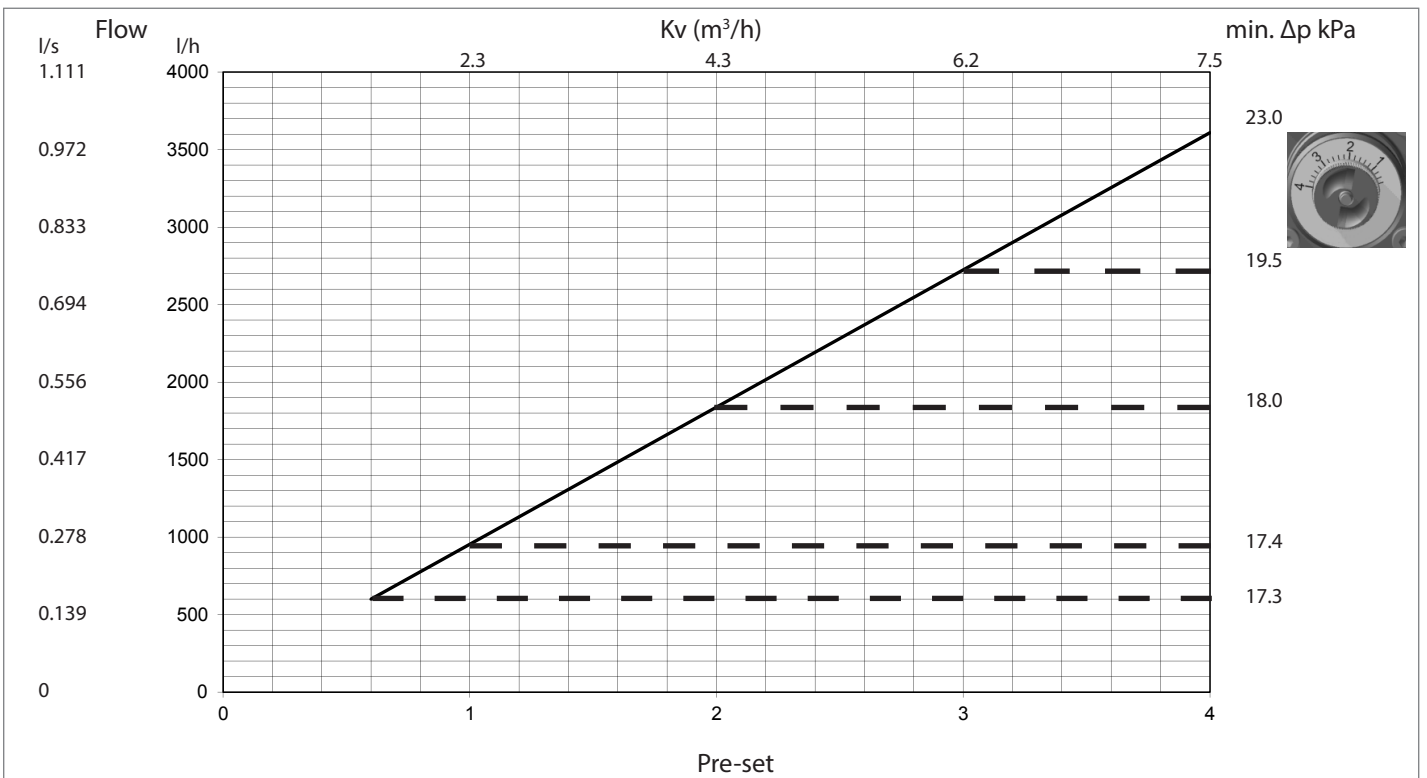

For further details: See OPTIMA Compact PICV Technote



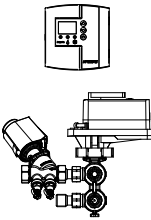
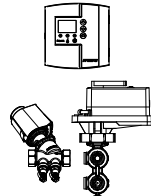

Frese OPTIMIZER 6-way Pressure Independent Control Group

Product programme OPTIMIZER 6-way Pressure Independent Control Group

	Size	Type	Flow l/h	Weight kg	Frese no.
	DN15	Frese OPTIMIZER 6-way LF incl. DZR brass couplings	65-370	2.85	53-1846
		Frese OPTIMIZER 6-way HF incl. DZR brass couplings	220-1330	2.85	53-1847
	DN20	Frese OPTIMIZER 6-way incl. DZR brass couplings	300-1800	4.30	53-1848
	DN25	Frese OPTIMIZER 6-way incl. DZR brass couplings	600-3609	5.20	53-1849
	DN15	Frese OPTIMIZER 6-way LF excl. couplings	65-370	2.45	53-1854
		Frese OPTIMIZER 6-way HF excl. couplings	220-1330	2.45	53-1855
	DN20*	Frese OPTIMIZER 6-way excl. couplings	300-1800	3.60	53-1856
	DN25	Frese OPTIMIZER 6-way excl. couplings	600-3609	4.30	53-1857

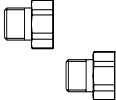
* Please note the 6-way valve is DN25 (G1")

Accessory

	Type	Frese no.	
	Frese 6-way valve DZR brass CW602N	DN15	44-0001
		DN25	44-0003
	Couplings DZR brass CW602N (2 pieces incl. gaskets)	DN15 (G 1/2- R 1/2)	43-2331
		DN20 (G 1- R 3/4)	43-3330
		DN25 (G 1- R1)	43-3331
	Frese rotating actuator for Frese OPTIMIZER 6-way valve	48-5535	
	Frese OPTIMIZER control unit incl. mounting kit	48-5546	
	Frese DELTA T temperature sensors, 2 m cable & cable ties	48-5547	

Frese OPTIMIZER 6-way Pressure Independent Control Group

Technical Specification Text

- The pressure independent control group shall, with only one data point from the external BMS system, ensure modulating control for both heating and cooling.
- The maximum flow for cooling shall be set on the pressure independent control valve and the heating flow shall be set on the control unit in the range from 10% to 100% of maximum cooling flow.
- The pressure independent control group shall be delivered as a total valve package and shall consist of:
 - 1 pcs. PICV with a 0-10V thermic modulating actuator.
 - 1 pcs. 6 way control valve with a motoric rotating 3 point on/off actuator
 - 1 pcs. control unit with a pipe connection bracket.
- The system shall safeguard loss of voltage by closure of flow.
- The 6-way control valve shall automatically once a week be partially rotated.
- The control unit shall be capable of providing a 0-10V DC feedback signal.
- Protection class for the actuators shall be IP 54 according to EN 60529.
- The valve housings shall be made in dezinification resistant brass (DZR).
- The pressure independent control valve shall have full stroke modulation and not be restricted by the flow setting position.
- The pressure independent control valve shall have a maximum operating differential pressure of 800 kPa (8 bar)
- The pressure independent control valve shall be capable of closing against a maximum differential pressure of 600 kPa (6 bar) DN15-20 and 800 kPa (8 bar) DN25 with a leakage rate at maximum 0.01% of the maximum rated volumetric flow and comply to EN1349 Class IV.
- The pressure independent control valve must be tested in accordance with the BSRIA document BTS.1 "Test Method for Pressure Independent Controls Valves" and manufacturer must be able to provide the test results upon request.

Frese A/S assumes no responsibility for errors, if any, in catalogues, brochures, and other printed matter. Frese A/S reserves the right to modify its products without prior notice, including already ordered products, if this does not alter existing specifications. All registered trademarks in this material are the property of Frese A/S. All rights reserved.

Frese A/S
Sorøvej 8
DK- 4200 Slagelse
Tel: +45 58 56 00 00
info@frese.dk

Frese