

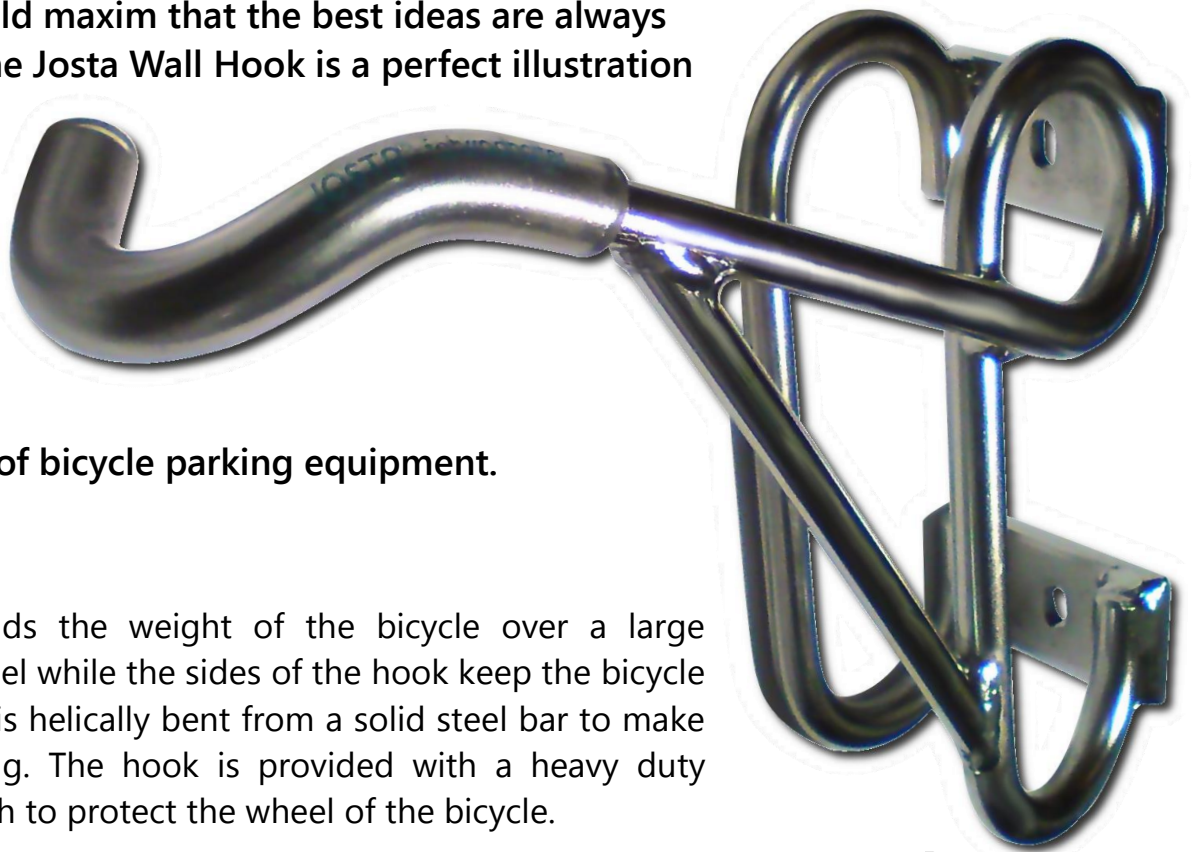

Cycle-Works

Josta Wall Hook

Remember the old maxim that the best ideas are always the simplest? The Josta Wall Hook is a perfect illustration of that. Josta have taken the concept of a simple hook to hang the bike by its wheel and created an ingenious piece of bicycle parking equipment.



Design

The design spreads the weight of the bicycle over a large section of the wheel while the sides of the hook keep the bicycle stable. The hook is helically bent from a solid steel bar to make it incredibly strong. The hook is provided with a heavy duty 3mm plastic sheath to protect the wheel of the bicycle.

Finish

The Josta Wall Hook is hot galvanized after assembly and can be powder coated after galvanizing if required. This high grade coating is available in all RAL colours. A stainless steel version of the Wall Hook is also available.

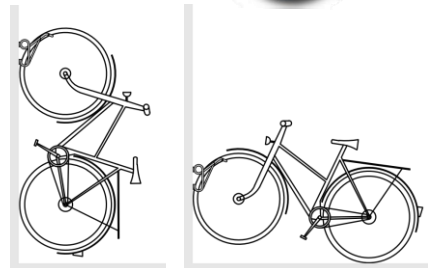

Cycle-Works Ltd

The Cycle Storage Specialists

cycle-works.com - 023 9281 5555

Josta Wall Hook

Hanging Positions

The Josta Wall Hook can be installed to park bikes in either a horizontal or vertical position. In both positions the racks should be vertically staggered to enable bicycles to be parked without handlebars or cables becoming entangled. The minimum separation between hooks is 425mm.

Horizontal Parking

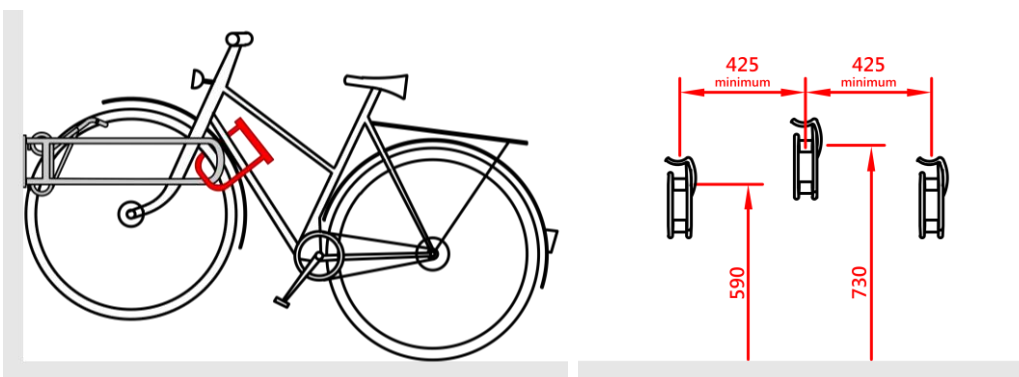

For horizontal parking hooks are installed alternately at heights of 590mm and 730mm above the ground.

The locking bar, if used, integrates with the hook giving a locking point for the front wheel and the frame.

Vertical Parking

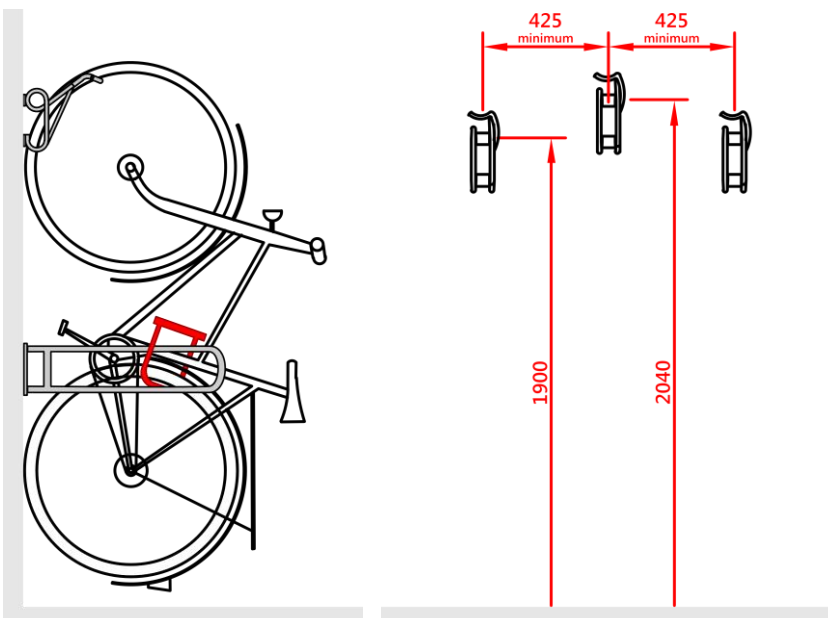

For vertical parking hooks are installed alternately at heights of 1900mm and 2040mm above the ground.

If a locking bar is required it is mounted to provide a locking point for the back wheel and the frame.

Security



The Josta Wall Hook can be supplied with an optional security bar to provide a secure locking point. This bar can be installed using the same bolts as the hook or on the wall or ground between hooks. In the latter case one security bar can serve two hooks.

Josta Wall Hook

Angled Mounting

The Josta Wall Hook can be supplied to mount at 90 or 60 degrees to the wall. Adaptor blocks can be provided to give angles of 45 or 30 degrees. Mounting at an angle reduces the projection of bikes into the surrounding space but means that the spacing between hooks must be increased.

Mounting at 90°

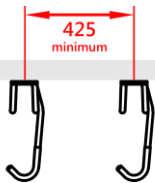

The standard way of mounting the Wall Hook is at 90 degrees to the wall. This allows the centres of the hooks to be spaced at 425mm and means that a standard bike will project about 1100mm from the wall.

Mounting at 60°

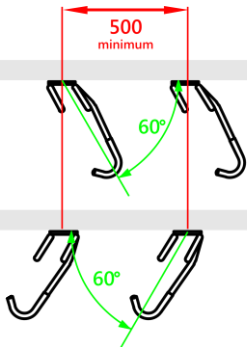

A variant of the Wall Hook allow bikes to be parked at 60 degrees to the wall. This means the centres of the hooks have to be spaced at least 500mm apart. Using 60 degree Wall Hooks reduces the projection of standard bike to approximately about 950mm from the wall.

The hook can be supplied so that the angle faces to the left or to the right.

Mounting at 45°

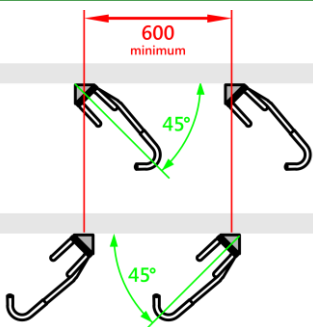

Using an adaptor block allows the standard Wall Hook to be mounted at 45 degrees to the wall. In this configuration the centres of the Wall hooks must be spaced at 600mm. At this angle the projection of a standard bike is reduced to approximately 780mm.

The hook can be install to face to the left or to the right by turning the adaptor block over.

Mounting at 30°

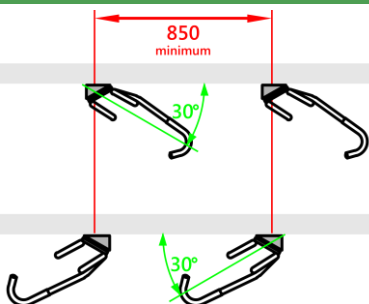

Using an adaptor block allows the 60 degree Wall Hook to be mounted at 30 degrees to the wall. In this configuration the centres of the Wall hooks must be spaced at 850mm. At this angle the projection of a standard bike is reduced to approximately 550mm.

The hook can be supplied so that the angle faces to the left or to the right.

Josta Wall Hook

Frameworks

Josta Wall Hook can be mounted onto frameworks for sites where it is impossible to fix the rack to the wall. This is useful where the walls are too weak to bear the full weight of the bike, or where the wall cannot be drilled.

These sturdy and well-constructed frameworks and racks hold the bicycle securely in place, while the optional security bar provides a locking point for the bike frame. This results in neat and organised individual parking.

The frameworks are made of 100mm mild steel box section, which is then galvanised and can be powder coated if desired. The frameworks are bolted to the floor for absolute stability.



About Cycle-Works

Cycling is our passion. We believe that cycling is good for people, good for society and good for the environment. This belief underpins everything we do. We believe that the provision of quality facilities will increase the use and acceptance of the bicycle.

All our employees and associates cycle regularly in diverse disciplines such as commuting, touring and long distance audax rides. We are active in both local and national cycle campaigning.



Cycle-Works Products

- Individual bicycle lockers
- High capacity 2-tier racks
- Open access and lockable shelters
- Wide range of individual racks
- Vertical and horizontal wall mounted racks
- Custom-made solutions

Visit our website to find out more.

Cycle-Works Services

- Initial site visits and advice on product selection
- Consultation on your construction plans
- Full delivery and installation services
- Aftercare and maintenance

 **We are a CHAS accredited supplier**



Cycle-Works Ltd

The Cycle Storage Specialists
cycle-works.com - 023 9281 5555