



# MODULAR SOCIAL DISTANCING SCREENS FOR FACTORIES & WAREHOUSES

PRACTICAL AND QUICK-TO-INSTALL SOLUTIONS TO REDUCE THE RISK OF TRANSMISSION AND ENABLE SAFE WORKING...

MODULAR SYSTEM  
CONFIGURE AS REQUIRED

- ✓ Free-standing barrier screens
- ✓ Segregate existing spaces / create additional rooms
- ✓ Partition gangways and entrances
- ✓ Production line segregation / individual workstations
- ✓ Welfare and canteen segregation
- ✓ Toilet block segregation

# FREE-STANDING SCREENS

Preassembled modular panels on support foot  
(with or without vision panel)

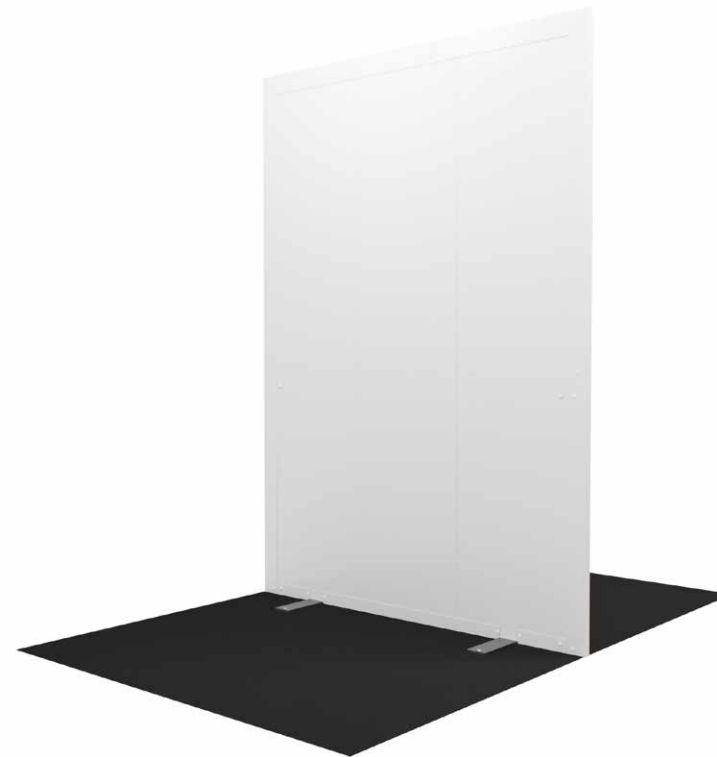

Hoardfast social distancing screens are available preassembled and ready to use.  
We can also supply a range of components for you to create bespoke solutions to meet your needs (on request).

# FREE-STANDING SCREENS

Modular panels on support foot

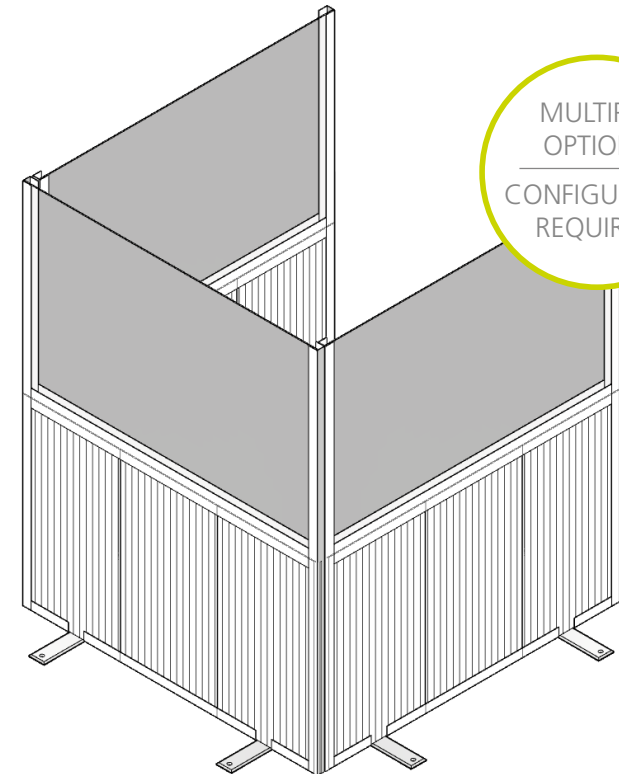
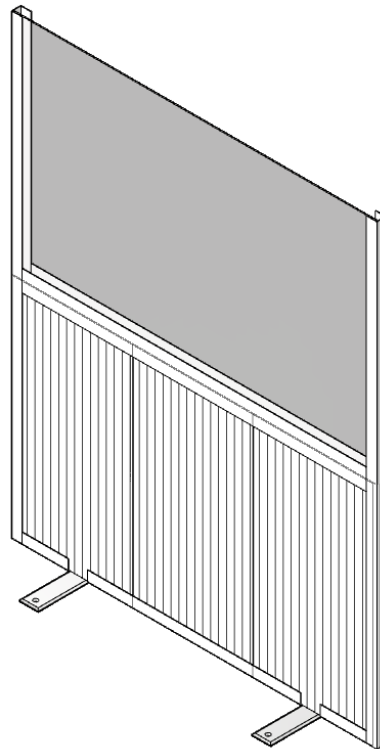
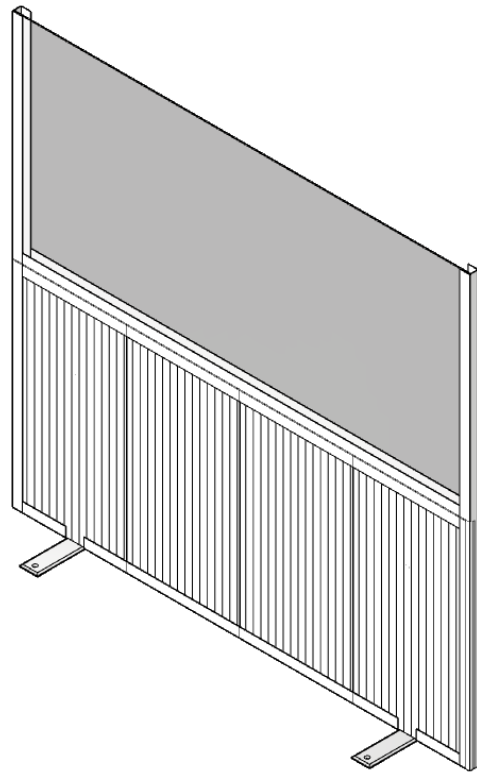





MULTIPLE  
OPTIONS  
—  
CONFIGURE AS  
REQUIRED

Preassembled segregation screens can be used in a number of different configurations to meet your requirements.

# FREE-STANDING SCREENS

Modular panels on support foot

	Product Name:	Details:	Materials:
	<b>1.5m (vision)</b>	<ul style="list-style-type: none"> <li>• Dimensions: 1.5m (w) x 35mm (d) x 1.9m (h)</li> <li>• Equal Foot Support: Inserts into hollow flute of the panel and protrudes each side of panel by 210mm.</li> <li>• Top 1000mm of screen is transparent acrylic panel</li> </ul>	<ul style="list-style-type: none"> <li>• Hoardfast Panel: 85% recycled PVC, 15% virgin PVC, grey hollow fluted internal and solid white ridged external face</li> <li>• Equal Foot Support: electroplated steel</li> <li>• Vision panel: Acrylic</li> </ul>
	<b>2m (vision)</b>	<ul style="list-style-type: none"> <li>• Dimensions: 2m (w) x 35mm (d) x 1.9m (h)</li> <li>• Equal Foot Support: Inserts into hollow flute of the panel and protrudes each side of panel by 210mm</li> <li>• Top 1000mm of screen is transparent acrylic panel</li> </ul>	<ul style="list-style-type: none"> <li>• Hoardfast Panel: 85% recycled PVC, 15% virgin PVC, grey hollow fluted internal and solid white ridged external face</li> <li>• Equal Foot Support: electroplated steel</li> <li>• Vision panel: Acrylic</li> </ul>
	<b>1m</b>	<ul style="list-style-type: none"> <li>• Dimensions: 1m (w) x 35mm (d) x 2.25m (h)</li> <li>• Equal Foot Support: Inserts into hollow flute of the panel and protrudes each side of panel by 210mm</li> </ul>	<ul style="list-style-type: none"> <li>• Hoardfast Panel: 85% recycled PVC, 15% virgin PVC, grey hollow fluted internal and solid white ridged external face</li> <li>• Equal Foot Support: electroplated steel</li> </ul>
	<b>1.5m</b>	<ul style="list-style-type: none"> <li>• Dimensions: 1.5m (w) x 35mm (d) x 2.25m (h)</li> <li>• Equal Foot Support: Inserts into hollow flute of the panel and protrudes each side of panel by 210mm</li> </ul>	<ul style="list-style-type: none"> <li>• Hoardfast Panel: 85% recycled PVC, 15% virgin PVC, grey hollow fluted internal and solid white ridged external face</li> <li>• Equal Foot Support: electroplated steel</li> </ul>
	<b>2m</b>	<ul style="list-style-type: none"> <li>• Dimensions: 2m (w) x 35mm (d) x 2.25m (h)</li> <li>• Equal Foot Support: Inserts into hollow flute of the panel and protrudes each side of panel by 210mm</li> </ul>	<ul style="list-style-type: none"> <li>• Hoardfast Panel: 85% recycled PVC, 15% virgin PVC, grey hollow fluted internal and solid white ridged external face</li> <li>• Equal Foot Support: electroplated steel</li> </ul>

# SOLUTIONS DELIVERED WITH A MODULAR SYSTEM



Practical and quick-to-install solutions

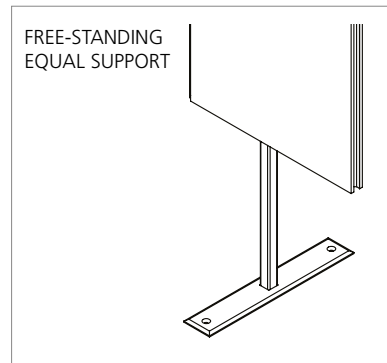
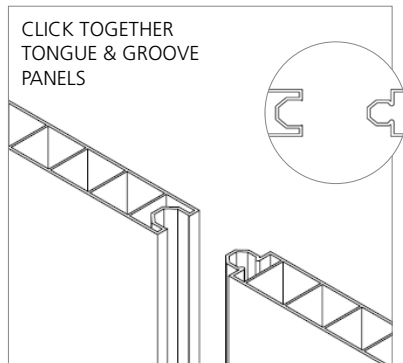

Hoardfast social distancing screens are available in pre-built configurations ready to use, or we can supply a range of parts for you to create bespoke social distancing solutions to meet your business needs...



Preassembled – ready to use

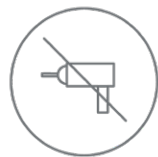

Free-standing – no fixing required

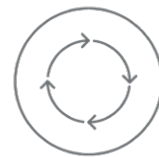

Reusable and relocatable



Hygienic wipe clean PVC panels



Sustainable – fully recyclable

# HOARDFAST SOCIAL DISTANCING SCREENS IN USE...

Hoardfast screens can be used in many environments including production line, process areas, canteen/dining spaces...





# ADDITIONAL EMPLOYEE WELFARE

Segregate existing common areas or create new spaces

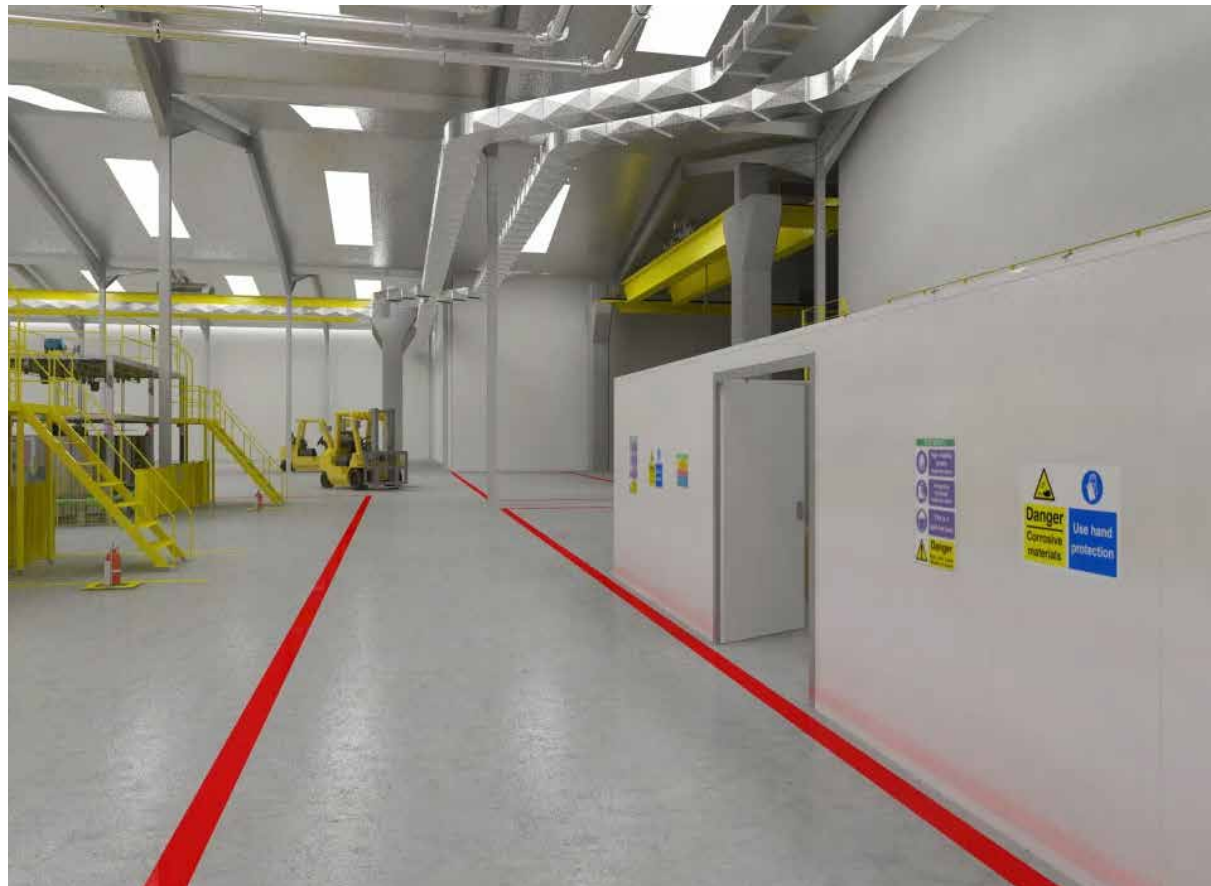

Ideal for companies running a rotating teams structure, create additional modular welfare spaces such as breakrooms and canteens with this free-standing temporary system. The modular design means that rooms and sizes can be designed to suit your requirements.

Vision panels, doors and a range of free-standing supports are available.



# NEED TO INSTALL SOCIAL DISTANCING MEASURES?

Call us on +44(0)1785 242181

or email us at [salesteam@westgateuk.co.uk](mailto:salesteam@westgateuk.co.uk)

Westgate provide hoarding for NHS Nightingale hospitals across the UK

Our Hoardfast screening system has recently been used to support the construction sector and NHS in delivering several Nightingale hospitals...

[Read our article](#)

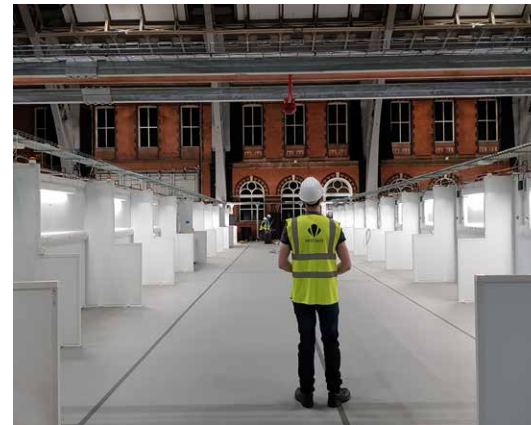





westgateuk



westgate\_uk



westgateuk1977

Westgate House, Verulam Road, Stafford ST16 3EA

[westgateuk.co.uk](http://westgateuk.co.uk)

+44 (0)1785 242181

[salesteam@westgateuk.co.uk](mailto:salesteam@westgateuk.co.uk)

---

Part of  Westgate Group

© Westgate Group