

**TYPICAL POST AND PANEL FIXING DETAIL**

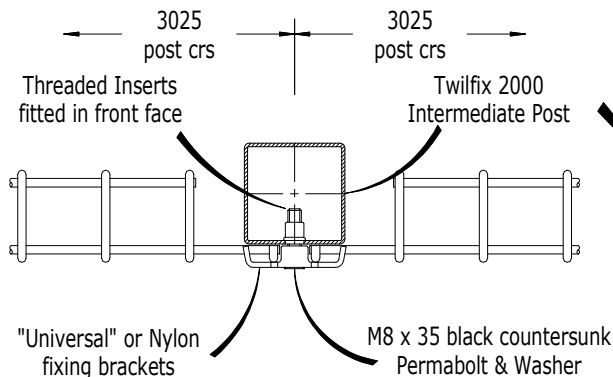

**PLAN VIEW ON INTERMEDIATE POST**

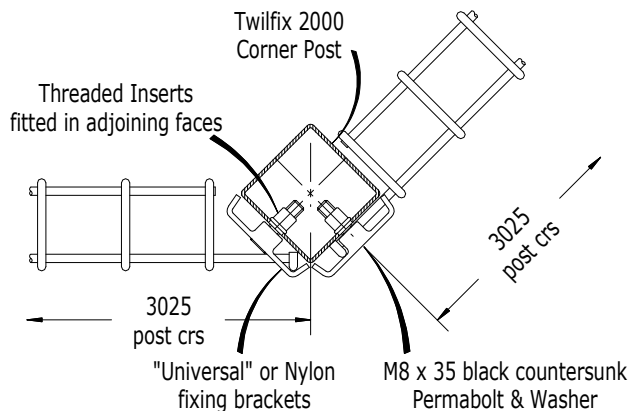

**PLAN VIEW ON OBTUSE CORNER POST**

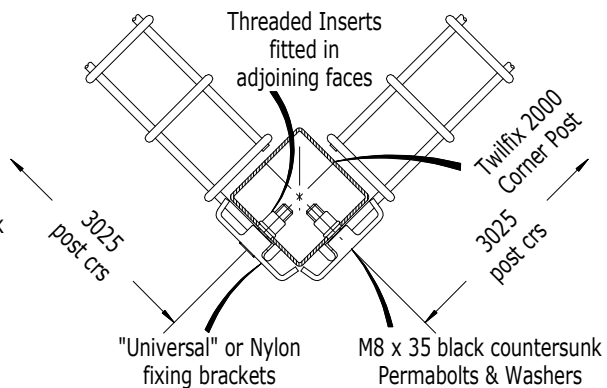

**PLAN VIEW ON 90° CORNER POST**

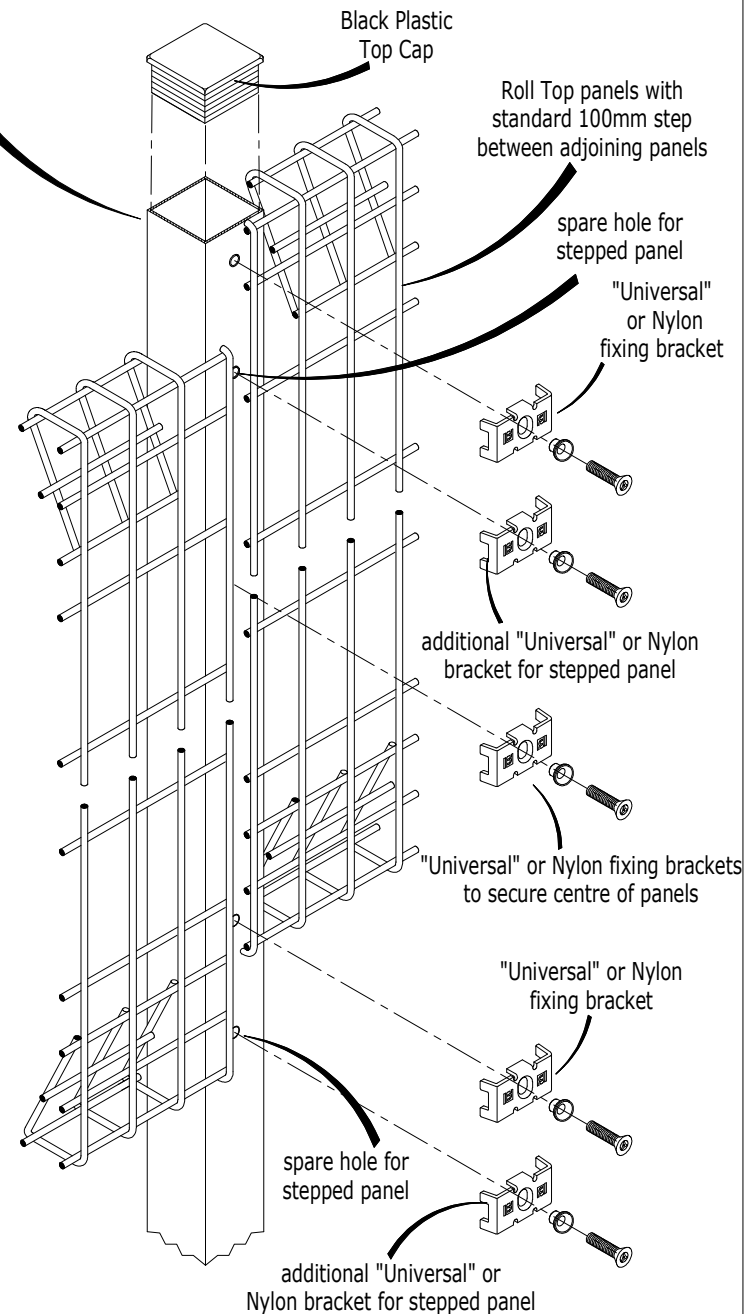

**STEPPING DETAIL FOR SLOPING GROUND**

**B BETA FENCE**

sales.sheffield@betafence.com  
www.betafence.com

Betafence Limited  
P.O. Box 119  
Shepcote Lane  
UK-Sheffield S9 1TY  
P: +44870 127 0027  
F: +44870 127 0028

Betafence Ltd. reserves the right to  
amend and withdraw products  
detailed herein, without prior notice

COPYRIGHT © 2014  
BETA FENCE LTD - SHEFFIELD - ENGLAND

**ROLL TOP**

Drawn

RB

Date

12.02.14

Drawing No :

**RT-B**

REV  
**b**

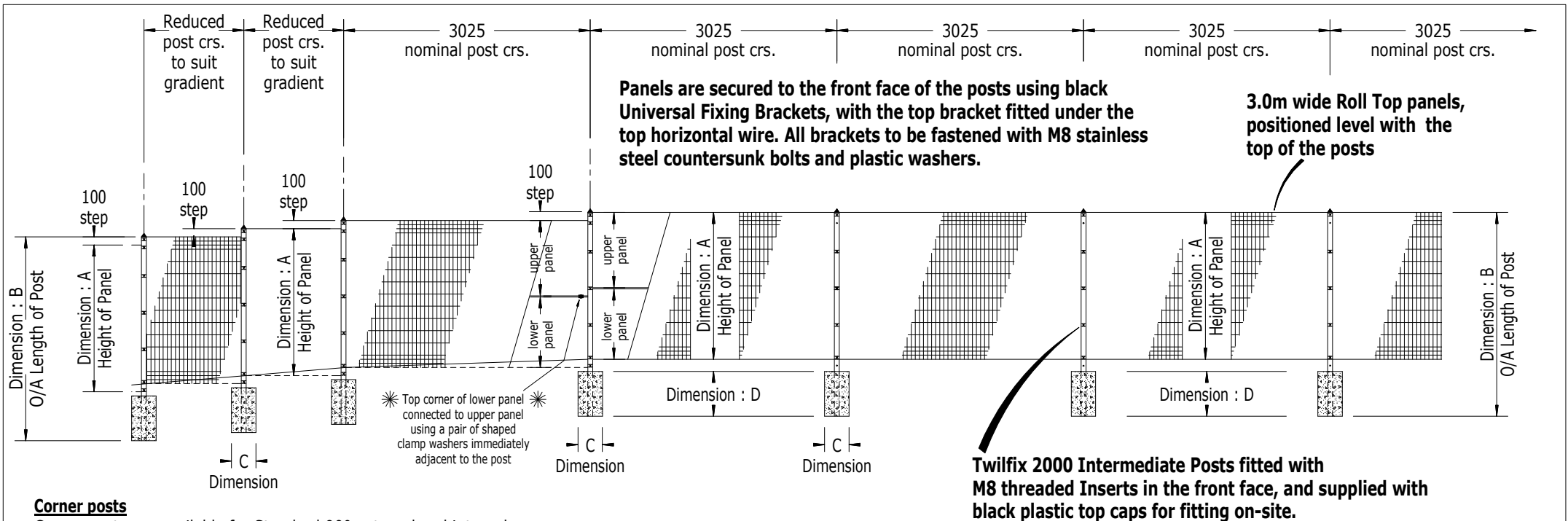

**Corner posts**

Corner posts are available for Standard 90° external and internal corners, and are also used for obtuse external and internal corners. End posts are not required.

**Gradients**

All standard Intermediate & Corner posts are fitted with 2no. additional threaded inserts at the top & bottom to facilitate 100mm steps between adjoining panels. Different gradients are achieved by reducing the post centres and width of panel to suit, ie :

- 3000 wide standard panel with 100mm step : 1 in 30 (3.3%) (1.9°)
- 2500 wide standard panel with 100mm step : 1 in 25 (4%) (2.3°)
- 2000 wide site-cut panel with 100mm step : 1 in 20 (5%) (2.9°)
- 1500 wide site-cut panel with 100mm step : 1 in 15 (6.6%) (3.8°)
- 1000 wide site-cut panel with 100mm step : 1 in 10 (10%) (5.7°)

Steeper slopes will require made-to-order extra long posts, manufactured with additional threaded inserts to suit the stepping required between adjoining panels to suit each gradient.

**Notes**

The preferred method of installation is : Post - Panel - Post - Panel, etc. Bolts may be installed using a Power-Driver and Power-Bit if preferred. When using hand tools, care must be taken to avoid over tightening of bolts.

Concrete Foundations must not be leaner by mass than 1 part cement to 10 parts 20mm nominal size graded aggregates, and must be thoroughly compacted prior to the initial set.

All Roll Top panels are supplied to site in a standard width of 3000mm. Panels for make-up bays are to be cut to suit on site, and made good using a Zinc Etch Primer paint, followed by a top coat of Cromadex 222 polyurethane repair paint.

Dim : A Panel Height	Dim : B Length Of Post	Dim : C Size Of Found's	Dim : D Depth Of Found's	Fixings Level Ground	Fixings Sloping Ground	IMPORTANT NOTE : The Foundation sizes indicated are for "normal" ground conditions only and may require modification to suit the prevailing ground conditions on-site.
900mm	1500mm	300mm	300mm	3no.	5no.	* <b>NOTE : 2.4m high fences</b> are achieved using 2no. 1.2m high panels, with an upper panel placed directly over a lower panel. Upper and Lower panels are then connected twice per bay using pairs of shaped clamp washers and M8 x 40 stainless steel button-head bolts. * <b>Where 2.4m high fences are stepped</b> , the Top Corner of the lower panel is connected to the upper panel using a pair of shaped clamp washers immediately adjacent to the post.
1200mm	1800mm	300mm	400mm	4no.	6no.	
1500mm	2100mm	300mm	500mm	4no.	6no.	
1800mm	2500mm	300mm	500mm	5no.	7no.	
2400mm	3100mm	450mm	500mm	7no.	9no.	

The Roll Top fencing system generally satisfies the requirements for Category : 1 (General Purpose) & Category : 2 (Security) fences as prescribed by B.S. 1722 Part : 14 - Open Mesh Steel Panel Fences