

COVEYA
COVEYA.CO.UK



CONVEYORS AVAILABLE FOR
SHORT & LONG
TERM HIRE



Coveya Conveyor Systems for Hire
The right hire conveyor to get the job done

The Coveya team has over **30 years' experience**

designing, manufacturing, supplying, maintaining and servicing market-leading conveyor systems for a vast range of industries and applications. Coveya is one of the most respected conveyor hire companies, working with customers throughout the UK and worldwide.

Over the past 30 years we've been proud to work with...

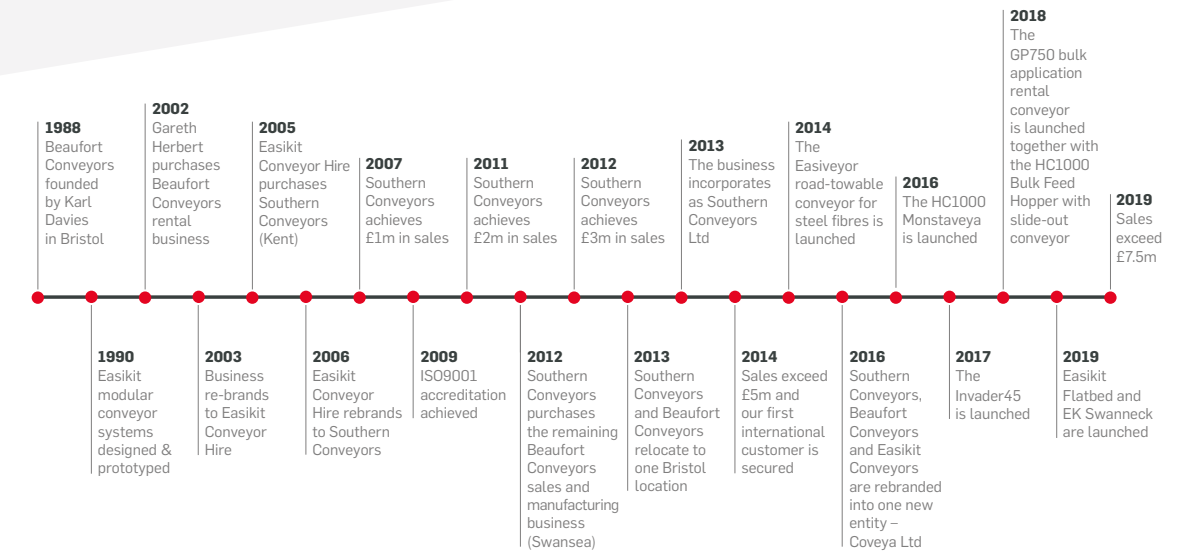

WE ARE PASSIONATE ABOUT THE QUALITY OF THE PRODUCTS WE PROVIDE AND THE SERVICE WE DELIVER

We are dedicated to helping our customers fast-track their onsite material movements and cut down project timescales, enabling significant improvements to safety and efficiency, especially in challenging situations. We can also provide bespoke conveyors that meet specific site requirements.

We offer advice on the best conveyor to use for your specific application, free site visits, full installation and a 100% money back guarantee if a conveyor fails. With a dedicated sales team to help you through every stage of your conveyor rental or purchase, Coveya is committed to adding value and delivering more.

WE ARE EXPERTS IN SUPPLYING CONVEYORS WITHIN A RANGE OF SECTORS

- Aggregates
- Construction
- Excavation
- Demolition & Remediation
- Factories & Warehouses
- Landscaping & Groundworks
- Rail, Ballast & Tunnelling
- Recycling & Waste Management
- Water Treatment & Reservoirs

T. 0800 915 9195

E. sales@coveya.co.uk

W. www.coveya.co.uk

[@wekeepyoumoving](https://twitter.com/wekeepyoumoving)

[linkedin.com/company/coveya](https://www.linkedin.com/company/coveya)

Coveya Product Range

PRODUCT	BUILDING & CONSTRUCTION	RECYCLING	LANDSCAPE & GROUNDWORKS	DEMOLITION & REMEDIATION	RESERVOIR MAINTENANCE	RAIL	BASEMENT EXCAVATION	AGRICULTURE	COMPOSTING & BIOMASS	WATER TREATMENT & RESERVOIRS	READY MIX CONCRETE ADDITIVE	FACTORIES & WAREHOUSES	AGGREGATES	SEWAGE & SLUDGE	CAPACITY	PAGE
Invader 45™	✓	✓	✓	✓	✓	✓	✓	✓					✓		<50tph	6
Easikit™ 300	✓			✓			✓	✓	✓				✓		<20tph	8
Easikit™ 450	✓	✓	✓	✓	✓	✓	✓	✓	✓				✓		<50tph	10
Easikit™ 600	✓	✓	✓	✓		✓	✓	✓	✓	✓			✓		<100tph	12
Easikit™ 900	✓	✓				✓		✓	✓				✓		<125tph	14
The Easiveyor™								✓			✓		✓		<50tph	16
Easikit™ Mobile		✓				✓		✓	✓				✓	✓	from <100tph using EK600 to <200tph using EK1200	18
HC1000 Monstaveya™		✓		✓		✓		✓	✓						<500tph	20
The GP750		✓		✓		✓		✓	✓						<300tph	22
Bulk Feed Hopper FH510		✓		✓				✓					✓		15m³ bulk capacity	24
Stockpiller		✓		✓		✓		✓	✓						500tph	26

Invader 45™

Designed for mobility, power and ease of use, our unique 'plug and play' conveyor provides an immediate solution. It's really easy and quick to set up and move around site with its optional wheeled undercarriage.

The Invader 45™ is extremely reliable (with 99% trouble-free rental across 9,000 rental days), low maintenance, economical to run and has been designed to eliminate downtime.



PRODUCT FEATURES

30mm cleated belt moves more material at steeper angles

Start or stop the conveyor from either side with **dual controls**

Easy to transport in LWB van and can be loaded/unloaded single-handed or in a stack using a forklift

Full length **impact protection** under the belt instead of rollers, reducing wear and risk of damage

Neatly stackable for compact storage

Digital volt meter instantly shows if there is a problem with the power supply

Removable wheeled undercarriage for easy manoeuvrability and adjustable support

Integrated scaffold tube holes for straightforward and **safe support**

1.5kW motor with twice the power of other conveyors in its class

Large **removable hopper** to suit a wide range of applications

Ergonomic drop-down handles for easy manoeuvring

SPECIFICATIONS	
Industry	Building & Construction, Recycling, Landscaping & Groundworks, Demolition & Remediation, Reservoir Maintenance, Rail, Basement Excavation, Agriculture, Aggregates
Power supply	110V
Type of material	Aggregate, Small rubble, Soil
Loading method	By hand, Small machine, Wheelbarrow
Mobile or static	Mobile, Static
Length	4m or 6m
Weight	160kg or 200kg
Belt width	450mm
Belt speed	0.75m/s
Maximum throughput	50 tons p/h
Hopper size (if used)	650 x 800mm
Max. incline angle	40°
Belt load	200kg
Motor power	1.5kW
Max discharge height	2525mm or 3715mm



WHAT OUR CUSTOMERS SAY

"I have had six Invaders on hire for six weeks and haven't had a single phone call. We've never had a hire like this with any other conveyors".
Plant Manager,
Plant Hire (London)

"It's saved me thousands of man-hours. It's the best bit of kit we've ever had on this site!"
Site Supervisor,
Construction Company



Easikit™ 300

Engineered for high performance materials handling in tight spaces, the popular Easikit 300 is the narrowest conveyor in our range, making it ideal for basement excavations, cellar refurbishments and sites with restricted access.

The modular Easikit 300 system is compact, lightweight, yet powerful. Designed for efficiency, we include installation and training on how to use the conveyor. The Easikit 300 safely handles up to 20 tons per hour, even at inclines of 45 degrees.

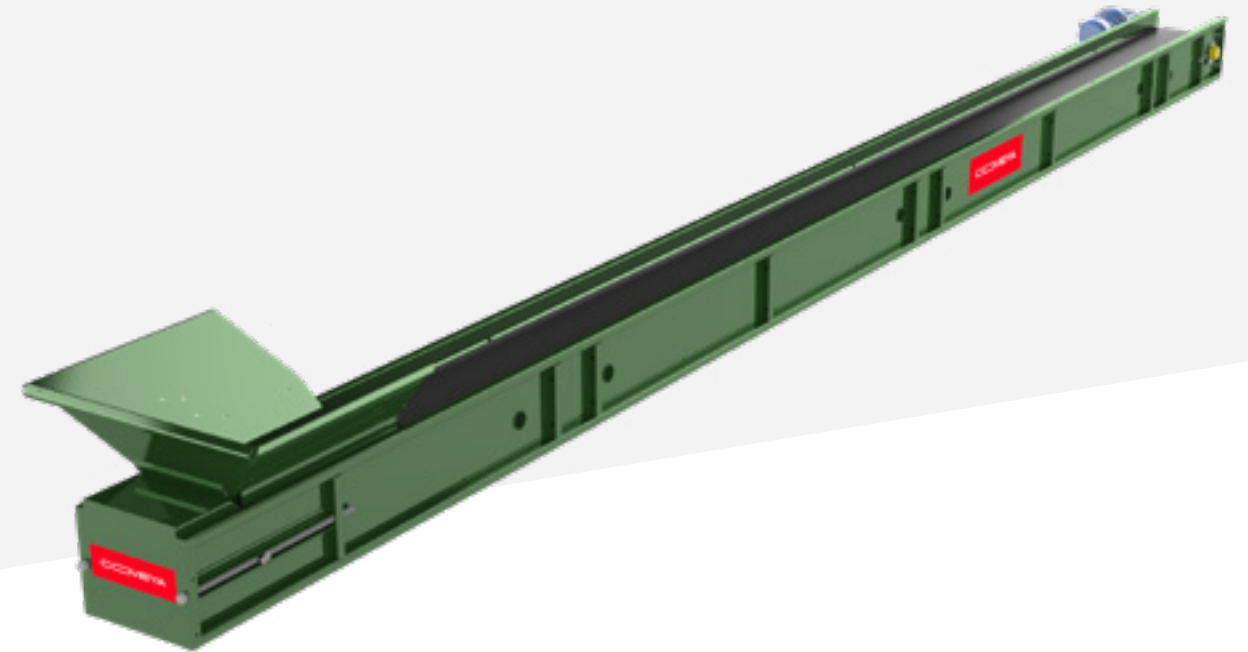

SPECIFICATIONS			
Industry	Building & Construction, Demolition & Remediation, Basement Excavation, Agriculture, Composting & Biomass, Aggregates	Weight	Variable 60kg/m
Power supply	110v	Belt width	300mm
Type of material	Aggregate, Small rubble, Soil	Belt speed	0.9m/s
Loading method	By hand, Small machine, Wheelbarrow	Maximum throughput	20 Tons p/h
Mobile or static	Static	Hopper size (if used)	750x800
Length	Up to 14.5m		

SECTIONS	L (mm)	W (mm)	H (mm)	Kg
Head Unit (no motor)	800	540	315	40
Head Unit with 1.5kW Motor	800	630	315	66
Base tension unit	1790	400	320	70
1.2m Section	1250	390	315	36
2.4m Section	2450	390	315	72
Steel Hopper	750	800	330	20



Easikit™ 450

The Easikit™ 450 is a simple and compact modular system with a large capacity, which is perfect for low volume material handling. Its robust design supports the removal of rubble and light hard core and it also has a detachable feed hopper.



SPECIFICATIONS	
Industry	Building & Construction, Recycling, Landscaping & Groundworks, Demolition & Remediation, Reservoir Maintenance, Rail, Basement Excavation, Agriculture, Composting & Biomass, Aggregates
Power supply	110V or 415V
Type of material	Aggregate, Small rubble, Soil
Loading method	By hand, Small machine, Wheelbarrow
Mobile or static	Static
Length	Up to 20m
Weight	Variable 50kg/m
Belt width	450mm
Belt speed	0.9m/s
Maximum throughput	50 tons p/h
Hopper size (if used)	630 x 800mm
Max. incline angle	45°

SECTIONS	L (mm)	W (mm)	H (mm)	Kg
Head Unit (no motor)	960	960	310	53
Base tension unit	1190	1190	310	72
1m section	1050	1050	310	35
2m section	2050	2050	310	65

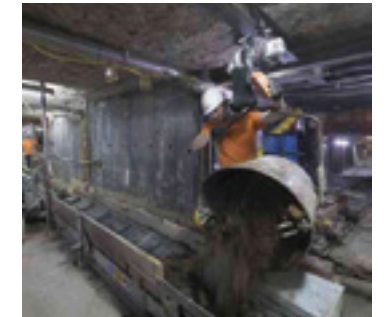

CASE STUDY

Claridge's Basement Excavation

When McGee Group agreed to build a 5-level basement underneath Claridge's Hotel in London, while keeping the hotel open for business, the Easikit 450 was the first choice. The new basement will house a gym, swimming pool, restaurant, retail space, meeting rooms and hotel services, as well as allowing the relocation of plant rooms at the top of the hotel to free-up space for 40 new bedrooms.

- 100s of tons of material moved each day through a 2m x 2m opening
- Easikit™ 450 and Easikit™ 600
- Operating up to 21 hours a day for over 2 years
- 6,000 sq. m of new floorspace to be created underneath the hotel

WHAT OUR CUSTOMERS SAY

"I'm pleased to say that Coveya provided us with an excellent service starting off with the design of the systems we wanted to a very efficient installation. Throughout the project the conveyors work extremely well, with very few breakdowns and when we did have any problems such as a tear on the belt replacement, they provided an excellent call out service and we're generally here within a couple of hours".

Jim Mackey, McGee Group

Easikit™ 600

The Easikit 600™ can be used across a range of sites including large excavation projects due to its considerable output and ease of loading by machine.

SPECIFICATIONS			
Industry	Building & Construction, Recycling, Landscaping & Groundworks, Demolition & Remediation, Rail, Basement Excavation, Agriculture, Composting & Biomass, Water Treatment & Reservoirs, Aggregates	Weight	Variable 70kg/m
Power supply	415V	Belt width	600mm
Type of material	Aggregate, Rubble, Small rubble, Soil, Dewatered sewage	Belt speed	0.2m/s – 1.2 m/s
Loading method	By hand, Excavator, Small machine, Wheelbarrow	Maximum throughput	100 tons p/h
Mobile or static	Static	Hopper size (if used)	785 x 850mm or 940 x 940mm
Length	Up to 40m	Max. incline angle	35°

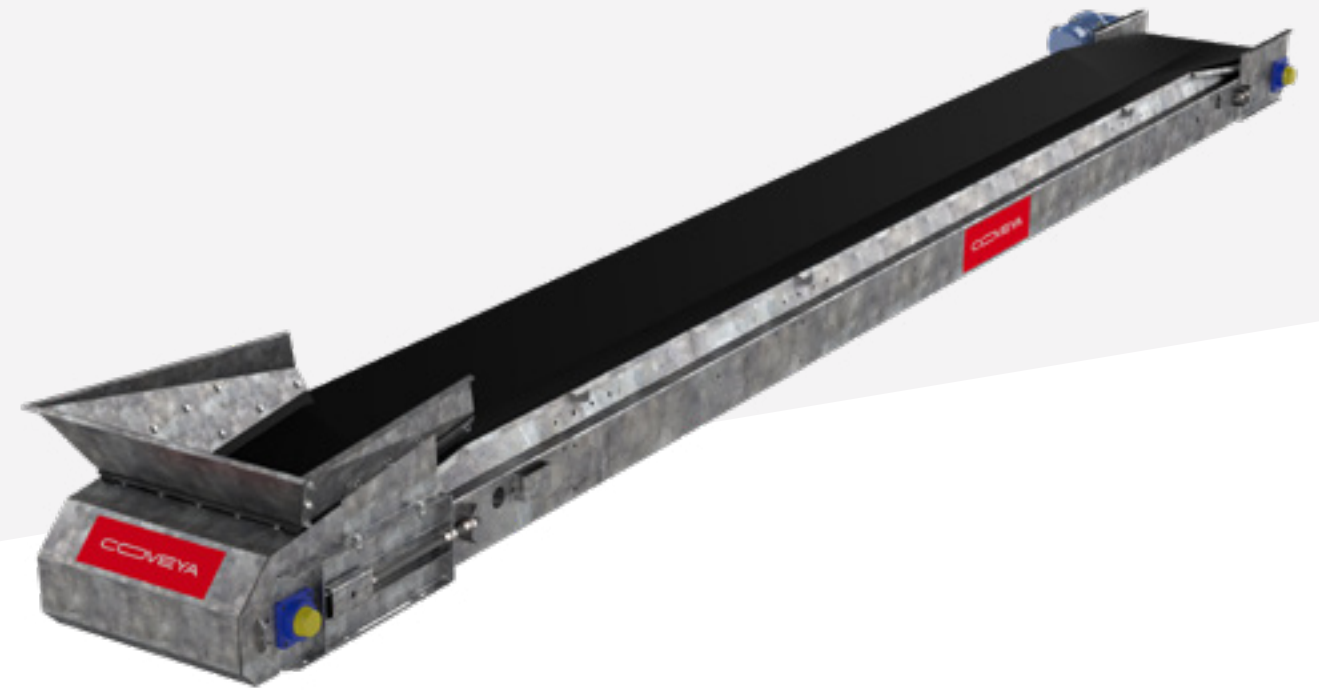

CASE STUDY

Keeping Network Rail on track

The platform at Liverpool's Lime Street Station was being lengthened for new trains. Old tracks had to be ripped up and moved and two disused service tunnels lay in the way of the new track routes. Spoil from the platform extension was moved into the tunnels but it flooded, therefore the pile of excavated sand on the track side was able to be efficiently moved to avoid a major project delay.

- Two exposed tunnels too weak to allow heavy plant to cross them
- Material needed to be moved 20m over the tunnels to avoid disrupting normal station activity
- 3 x Easikit™ 600 conveyors (6.4m each) with custom-made wheeled frames and a silenced generator

SECTIONS	L (mm)	W (mm)	H (mm)	Kg
Head Unit (no motor)	1505	930	285	85
Head Unit (with motor)	1525	1015	300	120
Base tension unit	1545	730	285	93
1.2m section	1350	625	285	43
2.4m section	2550	625	285	85
Available lengths	2.86, 4.06, 6.46, 7.66, 8.86, 10.06, 11.26, 12.46, 13.66, 14.86, 16.06, 17.26, 18.46, 19.66, 20.86, 22.06, 23.26, 24.46, 25.66, 26.86			
Other	Plain, 15mm chevron, 50mm cleated belt		Fully galvanised	

Easikit™ 900

The modular Easikit™ 900 is designed to support high-volume loads and larger throughput which makes it perfect for recyclables and bulk materials handling. It can reach up to 40m on a single belt and with adjustable speeds of 0.2 – 1.2m/s, the Easikit™ 900 helps to significantly improve onsite productivity.

SPECIFICATIONS			
Industry	Building & Construction, Recycling, Rail, Agriculture, Composting & Biomass, Aggregates	Weight	Variable 80kg/m
Power supply	415V	Belt width	900mm
Type of material	Bulk materials, Recyclables	Belt speed	0.2m/s – 1.2 m/s
Loading method	By hand, Excavation, Wheelbarrow	Maximum throughput	125 tons p/h
Mobile or static	Static	Hopper size (if used)	940 x 1240mm
Length	Up to 40m	Max. incline angle	35°

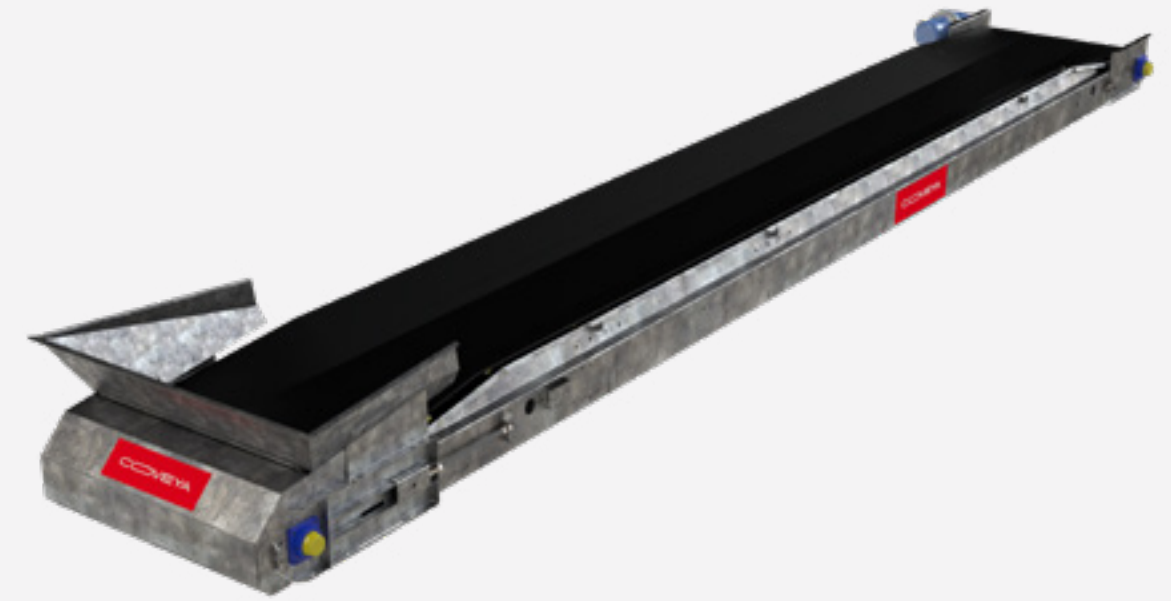

CASE STUDY

Helping to clear up at Glastonbury

With two shifts of ten volunteers on each of the 11 Coveya conveyor belts, 440 pickers worked 16 hours a day to sort through bags of rubbish, removing all plastic, paper and aluminium.

- 2,500 tons of rubbish to sift, sort and recycle
- 440 pickers working 16 hours a day
- 11 linked Easikit™ 900 conveyors
- 110m network of conveyors

SECTIONS	L (mm)	W (mm)	H (mm)	Kg
Head Unit (no motor)	1500	1225	310	103
Head Unit (with motor)	1500	1315	310	138
Base tension unit	1500	1020	285	111
1.2m section	1350	925	285	52
2.4m section	2550	925	285	96
Available lengths	2.86, 4.06, 6.46, 7.66, 8.86, 10.06, 11.26, 12.46, 13.66, 14.86, 16.06, 17.26, 18.46, 19.66, 20.86, 22.06, 23.26, 24.46, 25.66, 26.86			
Other	Plain, 15mm chevron, 50mm cleated belt		Fully galvanised	

The Easiveyor™

The Easiveyor™ is a unique, road-towable 5 metre Easikit™ 450 conveyor mounted on a trailer chassis, which is perfect for steel fibre handling. It comes complete with a 1.5kW 110v wired connection - simply 'plug-and-play' right off the truck and with an empty weight of well under 750kgs, the Easiveyor™ can be towed by most vehicles without any special licence.

SPECIFICATIONS			
Industry	Agriculture, Ready Mix Concrete Additive, Aggregates	Weight	685kg
Power supply	110V	Belt width	450mm
Type of material	Steel fibres	Belt speed	0.6m/s
Loading method	By hand, From boxes	Maximum throughput	30 tons p/h
Mobile or static	Mobile	Hopper size (if used)	630 x 800mm
Length	5.99m	Max. incline angle	45°

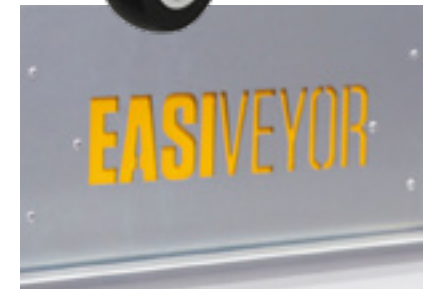

Easikit™ Mobile

The Easikit™ Mobile 600, 900 & 1200 is the ideal solution for variable discharge heights. It's durable, weatherproof, easy to move around onsite and has a hydraulic ram to achieve inclines of up to 35 degrees.

SPECIFICATIONS			
Industry	Recycling, Rail, Agriculture, Composting & Biomass, Aggregates, Sewage & Sludge	Weight	Variable 100kg/m
Power supply	110V or 415V	Belt width	600mm, 900mm, 1200mm
Type of material	Aggregate, Recyclables, Sludge, Soil	Belt speed	0.2 m/s – 1.2 m/s
Loading method	By hand, Excavator, Small machine, Wheelbarrow	Maximum throughput	100 tons p/h
Mobile or static	Mobile	Hopper size (if used)	Variable
Length	Up to 14.86m	Max. incline angle	35°



HC1000 Monstaveya™

Precision-engineered for heavy-duty materials movement, the HC1000 Monstaveya™ is our most powerful conveyor solution. Designed to handle virtually all types of excavated material and demolition spoil safely and easily, this high-capacity unit provides exceptional throughput and durability, ideal for even the most challenging projects. It's capable of loading an 8-wheeler in just 6 minutes and this hardwearing conveyor helps to minimise downtime, reduce fuel, maintenance and labour costs from day one.



SPECIFICATIONS	
Industry	Recycling, Demolition & Remediation, Rail, Agriculture, Composting & Biomass
Power supply	415V
Type of material	Aggregate, Demolition rubble, Excavation spoil, Rubble, Small rubble, Soil
Loading method	Excavator, Large machine
Mobile or static	Static
Length	10m, 12m, 14m, 16m
Weight	3500kg
Belt width	1000mm
Belt speed	1.2m/s
Maximum throughput	500 tons p/h
Hopper size (if used)	1100 x 1800
Max. incline angle	30°



CASE STUDY

Minimising downtime for Crossrail

Crossrail contractor Colas needed to replace the ballast on a single-wide track at Gidea Park Station, but their excavator arms couldn't reach across the platform.

We supplied an innovative solution that minimised track disruption, helping them to complete the work quickly and reliably.

- Up to 500 tons of ballast per hour
- Entire project had to be completed over a bank-holiday weekend
- 3 x HC1000 Monstaveyas™, each 1m wide and 10-12m long including unique wheeled frames



The GP750

The GP750's high-performance system and robust design make it the first choice for demolition sites. Its wide belt and 5.5kW heavy-duty motor enable it to maintain a throughput of up to 300 tons per hour and it's designed to be low maintenance with a considerable lifespan.

SPECIFICATIONS			
Industry	Recycling, Demolition & Remediation, Rail, Agriculture, Composting & Biomass	Belt width	750mm
Power supply	415V	Belt speed	1m/s
Type of material	Aggregate, Demolition rubble, Excavation spoil, Rubble, Small rubble, Soil	Maximum throughput	300 tons p/h
Loading method	Bobcat, Excavator	Hopper size (if used)	1100 x 1100mm
Mobile or static	Static	Max. incline angle	30°
Length	Up to 50m		

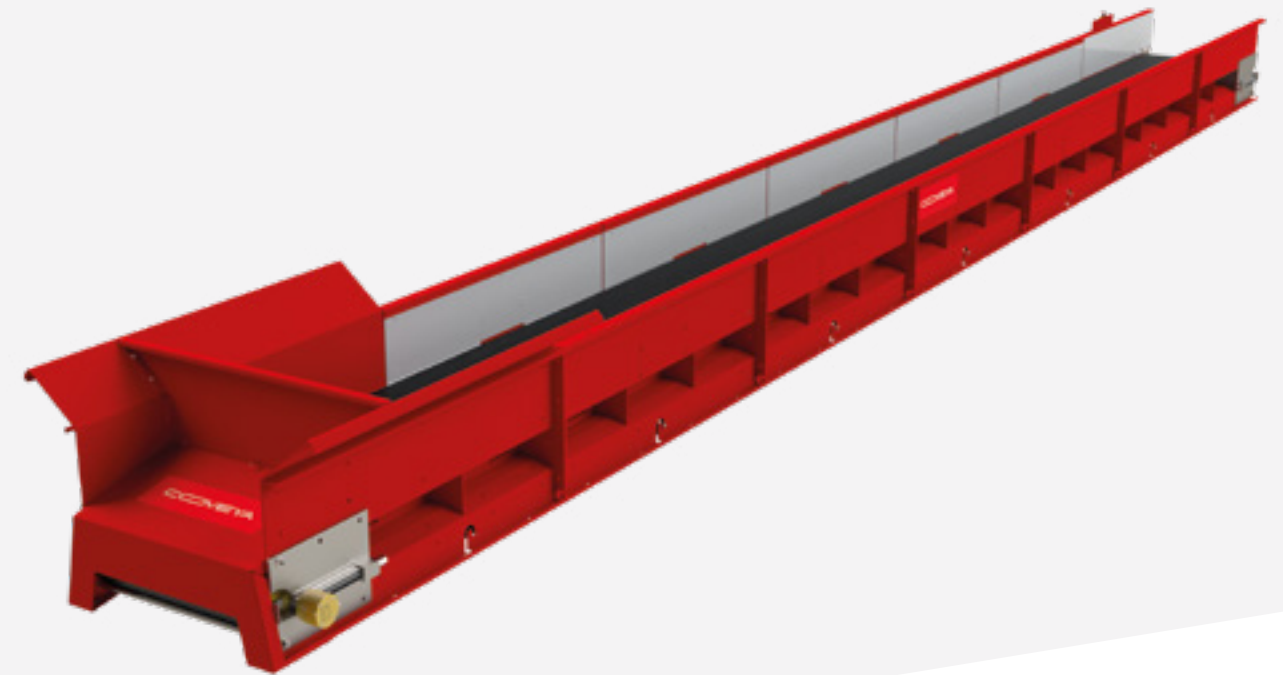

CASE STUDY

Morley House, London Basement Excavation

Built in 1924, Morley House forms two thirds of a Grade II listed block on London's Regent Street. The remaining third, Albany House, has already been converted to residential use.

Behind retained Portland stone facades, the building is being reconstructed and extended to provide 44 private rental apartments ranging in size from one to three bed, including two penthouse duplex units. Residents' amenities on the ground floor include a lounge and screening room. Retail space at ground and basement is enlarged and enhanced.

Our client Deconstruct were engaged by The Crown Estate and Keir Construction to carry out significant façade retention and demolition works to the building.



The demolition of the entire building whilst retaining the facade created a challenge when removing all the demolition rubble through the listed facade from the existing basement and into the back of a muck away truck which was parked in a closed road to the side of the building. Also, with a limited program for works, the rubble had to be removed as fast as possible.

Coveya installed a 20.0m GP750 conveyor which fed the material from the basement floor to the back of the lorry, and was loaded by a 14 ton excavator. The project included;

- Removing hundreds of truckloads removed rapidly and safely
- 10 – 15 minutes per truck loading time
- 30 trucks loaded during a short Saturday shift

Bulk Feed Hopper FH510

Our Bulk Feeder Hopper is designed to provide a controlled flow of material onto our conveyors, allowing operators to load systems efficiently with a wheeled loader or excavator. It provides a buffer of material to ensure continuous loading with a speed-adjustable belt and it's perfect for aggregates and demolition projects.

SPECIFICATIONS			
Industry	Recycling, Demolition & Remediation, Agriculture, Aggregates	Bulk capacity	15m ³
Power supply	415v Drive	Length	5m
Legs	Adjustable height	Width	2m
Discharge height	1m - 1.5m	Height	3.5m
Belt speed	Variable	Weight	5500kg
Discharge gate	Adjustable		

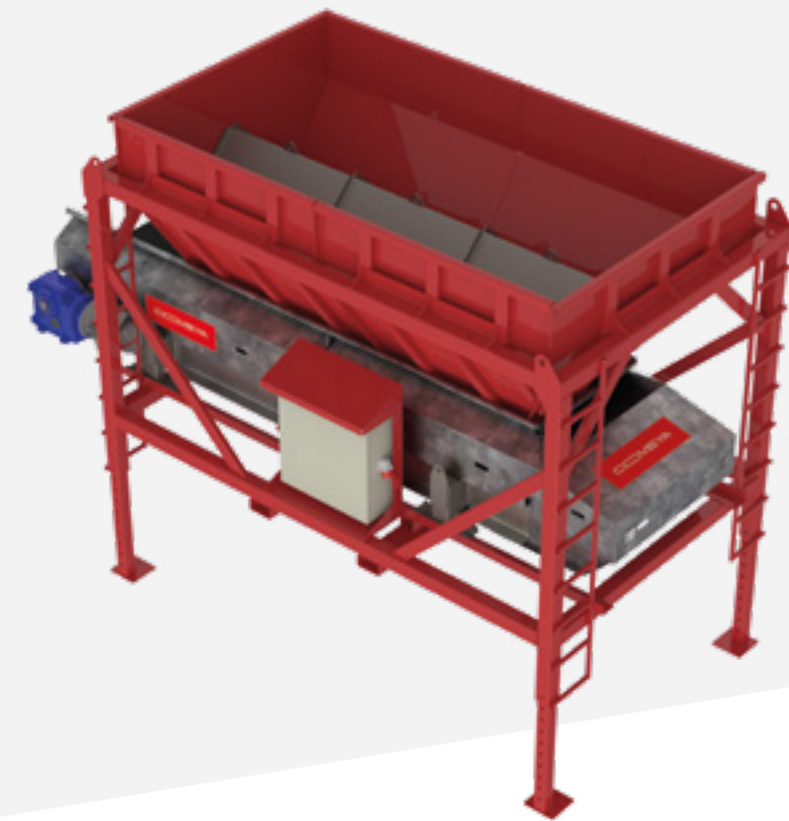

WE OFFER FREE EXPERT ADVICE AND SUPPORT

making sure you find the right conveyor for your specific needs

Wheeled & Tracked Stockpiler

The Coveya Wheeled & Tracked Stockpiler is the perfect solution for stockpiling materials. Its delivered on a low loader serviced, assembled and ready to use. The Coveya stockpiler is the perfect solution for stockpiling and handling high volumes of material from wheeled loaders, large excavators or direct from crushing units.



SPECIFICATIONS	
Industry	Animal feeds & agriculture, Composting & biomass, Demolition, Rail, Recycling
Type of material	Aggregate, Bulk materials
Loading method	Small machine
Mobile or static	Mobile
Length	18.0m
Weight	7500kg
Belt width	900mm
Belt speed	1.2m/s
Maximum throughput	500 Tons p/h



WE OFFER FREE EXPERT ADVICE AND SUPPORT

making sure you find the right conveyor for your specific needs

About Coveya

Coveya is a market-leading manufacturer and supplier of a range of commercial and industrial conveyor systems, for hire, supporting customers globally.

With over 30 years' experience, our ongoing success stems from the quality of our products, including bespoke and modular conveyors, our commitment to exemplary customer service and our investment in the design and development of conveyors that support current and future customer needs.

We strive to deliver a complete materials handling solution; from free site visits and advice, to implementation, servicing and repair, and with a high percentage of repeat customers, the Coveya team always focus on adding value and delivering more.

Speak to a member of the Coveya team

T. 0800 915 9195 E. sales@coveya.co.uk



Unconditional Guarantee

If our temporary conveyor system fails to provide tangible efficiencies on your project, we will remove it and you will not be charged



Free on-site survey



You can either **rent or buy** a range of conveyors from us

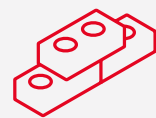

Modular conveyors that **keep your site moving**



If you need a **bespoke conveyor**, we can help



A real commitment to **adding value and delivering more**



Our customer service is **second to none**

"Pleased to say it did the job perfectly and we would not have any hesitation in recommending it to other contractors that have similar tasks to complete."

Groundworks Manager,
Glossbrook Builders

"The guys changed a belt and couldn't believe how quick it was. They're chuffed to bits with how easy the Invader 45™ is to work on."

Service Manager, Rental Company

"A big thanks to everyone at Coveya for the speedy technical responses, excellent delivery time and good value conveyor system."

GM, Capital Compactors & Balers

"Without the help of the Coveya system we wouldn't have been able to get the reservoir roof reinstated with 750 tons of gravel. It's been a Godsend and I'd like to use the system again in the future if need be."

Project Manager,
Future Industrial Services

INDUSTRY SECTORS

How Coveya can help you

Aggregates

Our Easikit Mobile is based on the modular Easikit™ 600 and comes in 600, 900 or 1200 with a mobile undercarriage. The Easikit™ Radial is built to order and is specifically designed for automatic radial slewing. Together with our Bulk Feed Hopper, we supply the perfect conveyor solutions for the aggregate industry, enabling the removal and movement of gravel, sand, recycled concrete, slag, topsoil and ballast across construction and rail sites throughout the UK and further afield.

Agriculture

We can supply a comprehensive range of conveyors to the agriculture industry, all of which are designed to efficiently enable the processing of mill, seed, grain and other farm products, as well as the general movement of materials including animal feed.

Basement Excavation

Coveya prides itself on manufacturing flexible and robust conveyors that are suitable for all types of excavation projects. The Invader 45™ and our range of Easikit™ conveyors are specifically designed for the removal of muck and materials sometimes within complex and constrained sites. Our conveyors have supported a range of projects including a basement excavation at Claridge's Hotel and Harley Street, London.

Building & Construction

Coveya supply a comprehensive range of conveyor systems that are specifically designed to support a vast range of building and construction projects throughout the UK. Our conveyors enable the movement of materials for everything from complex excavations to large scale sites, demolition and remediation. Our conveyors can be on site quickly and are designed to eliminate downtime, ensuring that any building project keeps on track. We also offer free onsite visits, making sure that our conveyors best suit your construction needs.

Composting & Biomass

Our Easikit™ series, together with our heavy-duty conveyor range, are perfect for biomass handling, woodchip, wood shavings, pellets, oversized materials, compostables and the movement of waste. They are robust, flexible and efficient, offering the exact conveyor solution you need.

Demolition & Remediation

We manufacture and supply conveyors that are perfect for both complex remediation and demolition sites to large scale rubble, clearance, asbestos and soil removal. Our Invader 45™, Easikit™ 450 and Easikit™ 600 conveyors enable the removal of materials from constrained sites and the HC1000 Monstaveya™ and GP750 are the largest of our conveyor solutions, supporting largescale demolition sites. Whatever your requirements, we will provide a conveyor that is fit for purpose.

Factories & Warehouses

Our conveyors are mobile, robust and flexible. We can quickly deploy the right conveyor on site without you having to go to the time and expense of designing and buying a bespoke solution. With various lengths in stock for hire or purchase, we can help you decide which conveyor is right for your factory and warehouse and get you moving as quickly as possible.

Landscaping & Groundworks

Coveya manufacture conveyors that are perfect for all types of landscaping and horticulture projects. Their modular design means that they are mobile, robust and flexible enabling you to move materials around and away from site easily and quickly. From moving sand around site, to creating a volleyball pitch at the 2012 Olympics and small and large landscaping, groundworks and horticulture projects, we have a range of conveyors that offer flexibility and quality.

Rail Track, Ballast Works, Demolition & Tunnelling

We have a series of conveyors that are perfect for national rail improvement, expansion, tunnelling & demolition projects and we have already supported a range of complex rail projects throughout the UK, offering a unique eco-friendly conveyor solution. Their modular design supports projects within constrained and larger sites, eliminating downtime, passenger and operational disruption and noise pollution.

Recycling & Waste Management

From festival recycling to major waste distribution and management outlets, our extensive range of modular conveyors are perfect for materials recovery, EFW plants, AD facilities, picking and baling plants. Each are robust and flexible, providing the perfect solution for recycling and waste management.

Water Treatment & Reservoirs

We supply a range of conveyors designed to meet the needs of reservoir, dam, tideway restoration and water treatment sites across the UK including the removal and relocation of aggregate, soil and sediment from areas with limited access or tunnels and the treatment of sewage, dewatered sludge, dried biosolids, cake and wastewater handling, alongside other treatment processes. We offer free onsite visits that help us to find out more about how the conveyor will be used, so that we can recommend the very best conveyor for your water treatment or reservoir project.

COVEYA
COVEYA.CO.UK

TALK TO THE COVEYA TEAM TO FIND OUT MORE

Call 0800 915 9195 | sales@coveya.co.uk