

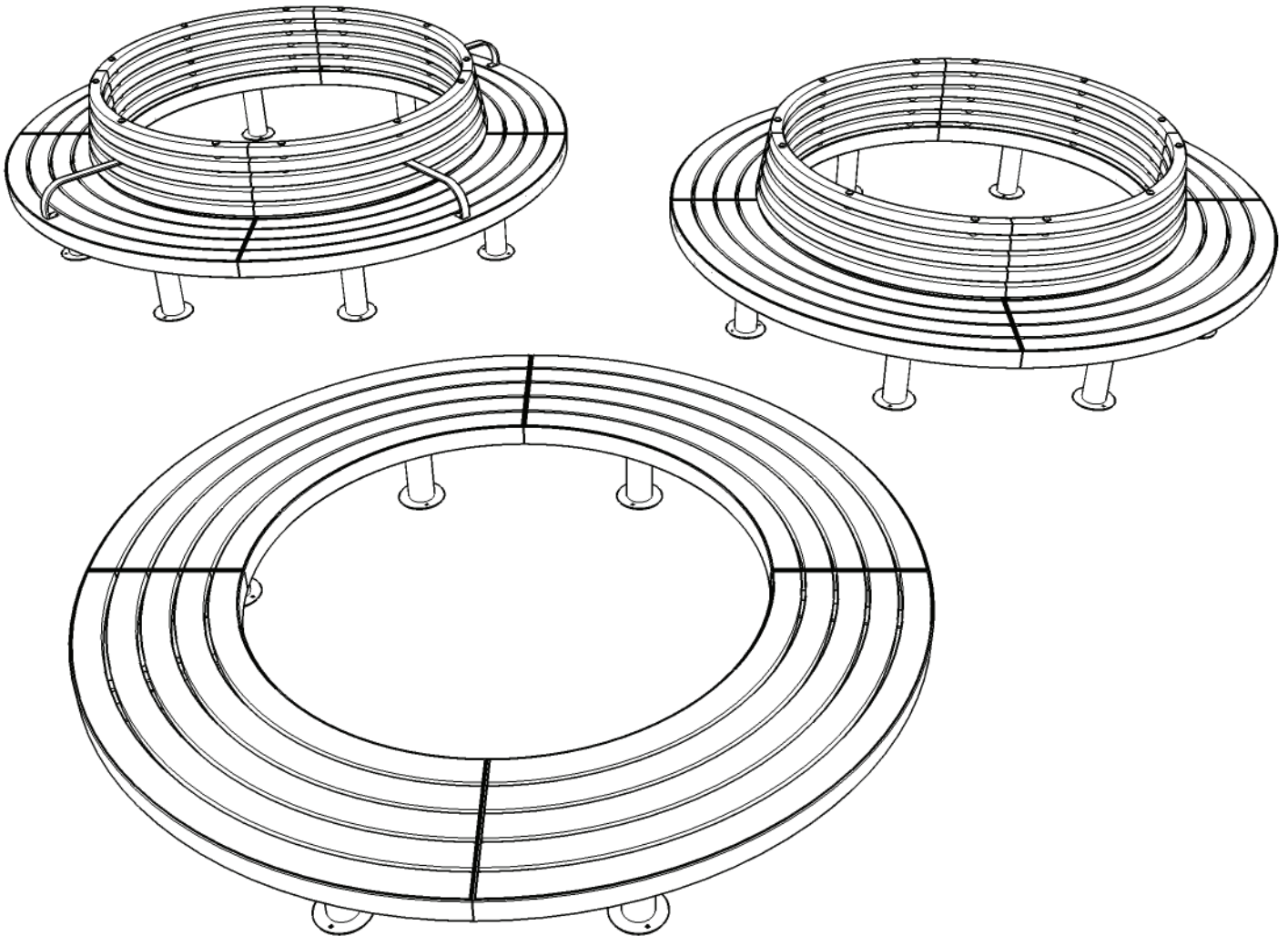

Factoryfurniture

TREE bench & seat - full



Operation & Maintenance Manual

Introduction

Design

Design, shop drawings and development by Factory Furniture Ltd

Manufacture

Factory Furniture manufactured components. Products are assembled in Factory workshops, checked and dispatched ready for installation. Replacement products or components thereof should be ordered direct from Factory Furniture Ltd

Copyright

The design copyright for the product and drawing copyright remains the sole property of Factory Furniture Ltd

General Specifications

Full Bench

Metric length 2800mm | width 2800mm | height 450mm*
Imperial length 9' 2" | width 9' 2" | height 1' 5½"

* Not including +100mm below ground level for sub-surface fix option

Approx Weight 242kg

Fixing Centres See installation dwgs at end of manual

Full Seat (with back)

Metric length 2800mm | width 2800mm | height 785mm*
Imperial length 9' 2" | width 9' 2" | height 2' 7"

* Not including +100mm below ground level for sub-surface fix option

Approx Weight 365kg (+8kg for armrest option)

Fixing Centres See installation dwgs at end of manual

Detailed Material & Finish Specifications

Bench Slats

- Manufactured from FSC® certified tropical hardwood (*other FSC timber options available upon request*)
- Profiled and left untreated as standard (*oil or microporous woodstain treatment available on request*)
- Bench slats supported by and fixed to frame with minimum 4 no. fixing points per slat



Backrest Slats (Seat only)

- Manufactured from FSC® certified tropical hardwood (*other FSC timber options available upon request*)
- Profiled and left untreated as standard (*oil or microporous woodstain treatment available on request*)
- Backrest slats held together and fixed to seat with 3 no. concealed zinc-coated mild steel threaded tie rods. Slats separated on tie rods by aluminium spacers and fastened on top by aluminium end caps and underneath by M12 locknuts

Bases / Frame / Armrests (Armrest optional - for seat only)

- Frame, bases and armrests manufactured from stainless steel with satin polished finish
- Bases fixed to frame with 2 no. M10 x 25mm button head bolts and locknuts per base (*8 bases / complete bench/seat*)
- Anchored using 2 no. resin fixed M10 x 200mm threaded rods and cap nuts per base (*surface fix*) or 2 no. zinc-coated steel M10 x 75mm sleeve anchors per base (*sub-surface fix*)
- Where armrests are included they are threaded onto the tie rods at one end and fixed at the other end to the outer seat slat with 2 no. fixing points. There are 4 no. armrest on the complete full tree seat
- Both Full tree bench / seat come in 4 no. sections that are each joined together using 2 no. M10 x 25mm button head bolts and locknuts through holes in the frame wall

General Maintenance (Recommended Schedule & Guidelines)

Daily/Weekly/Monthly (or as adopted)

Visual checks of bench / seat top, back and bases - check all items for superficial or physical damage.

Three Monthly

Clean all items as detailed below check all fixings are seated correctly; inspect timber for serious damage and splinters.

Six Monthly

Secure all fixings; full clean as detailed below; check that bench / seat is firmly secured to the ground

Specific Maintenance Details

FSC Timber

Clean with a stiff brush once per year, especially in more exposed locations, in order to prevent a verdigris type build up on the timber surface. Ideally this should be completed in early spring. During the cleaning stage, all exposed timber surfaces should be inspected for splits and splinters. Any splinters and graffiti should be removed and the surface sanded with 100 grit sandpaper in order to remove any uneven / sharp edges or surfaces.

During the first few months after installation the tannin naturally occurring in the timber may leach out and cause a brown staining on the bases. This may be removed with a light solution of household bleach and water.

Stainless Steel (polished stainless steel only)

Clean as required, but at least every three months, using a stainless steel polish and a lint free cloth. To remove ground in dirt, a stainless steel finishing pad may be required.

Repairs

FSC Timber

For light damage, please see section on specific maintenance details above. For instances of heavy damage, the timber item should be replaced. Please order against the part number reference in the reordering section towards the end of this manual.

Stainless Steel

Light damage (surface scratches etc.) can be removed using an emery pad (240 grit) and freeing oil such as 'WD40'. Care should be taken to follow the direction of the brushing grain. It is recommended that a trial repair be carried out on an unimportant surface first. No corrosive cleaners or other abrasives should be used. Any contamination, particularly carbon steel scuffs from vehicles, should be quickly removed to avoid corrosion.

Heavy Damage

In the event of serious damage to any component, replacements should be ordered from Factory Furniture Ltd. In this event (or if the product needs to be disassembled for any reason), please contact Factory Furniture for detailed technical advice.

Reordering / Spares

Part No.

Item Description

P1030 / 01

1 no. Quarter module bench slat set - includes bench slats (*15 slat parts in total*)*

P1030 / 02

1 no. Quarter module backrest slat set (seat only)- (*10 slat parts in total*)*

P1030 / 03

1 no. Backrest fixing set (*includes endcap, 5 no. spacers and threaded rod*)

P1030 / 04

1 no. Tree seat base (*please specify surface or sub-surface fix*) - suitable for bench & seat

**N.b. 4 no. quarter module slat sets are required to replace all slats on complete bench / seat*

Instructions For Reordering

If possible, please specify job name or number at the time of reordering to enable identification of details such as the original species of timber used, stainless steel finishes and polyester powder coat colours etc. In any event where either, additional orders are required, or spares and replacements are required please contact Factory Furniture Ltd. Using the part numbers given above as reference should help us to process your enquiry more efficiently.

Note - All fittings required to assemble ordered parts will automatically be included in the order.

AutoCAD Drawing List

FF1030 / 01

FULL TREE BENCH

OVERVIEW DRAWING

FF1030 / 02

FULL TREE SEAT (WITH BACK)

OVERVIEW DRAWING

FF1030 / 03

FULL TREE BENCH / SEAT (WITH BACK)

TYPICAL X-SECTION DRAWINGS

FF1030 / 04

FULL TREE BENCH / SEAT (WITH BACK)

TIMBER BENCH SLAT SET PARTS DETAIL

FF1030 / 05

FULL TREE BENCH / SEAT (WITH BACK)

TIMBER BACKREST SLAT SET PARTS DETAIL

FF1030 / 06

FULL TREE BENCH / SEAT (WITH BACK)

STEEL FRAME PARTS DETAIL

FF1030 / 07

FULL TREE BENCH / SEAT (WITH BACK)

BASE & BACKREST PARTS DETAIL

FF1030 / 08

FULL TREE BENCH / SEAT (WITH BACK)

SET OUT DRAWING

FF1030 / 09

FULL TREE BENCH / SEAT (WITH BACK)

OVERSIZE TEMPLATE DRAWING

FF1030 / 10

FULL TREE SEAT (WITH BACK)

ARMREST OPTION

Contacts

Factory Furniture Ltd, The Stableyard, Coleshill, Swindon. Wiltshire SN6 7PT U.K.

Tel +44 (0) 1793 763829

Fax +44 (0) 1793 861615

Email hello@factoryfurniture.co.uk

Web www.factoryfurniture.co.uk

Installation Instructions

ALL INSTALLATION WORKS TO BE CARRIED OUT BY COMPETENT PERSONNEL - INSTALL AS COMPLETE UNIT.

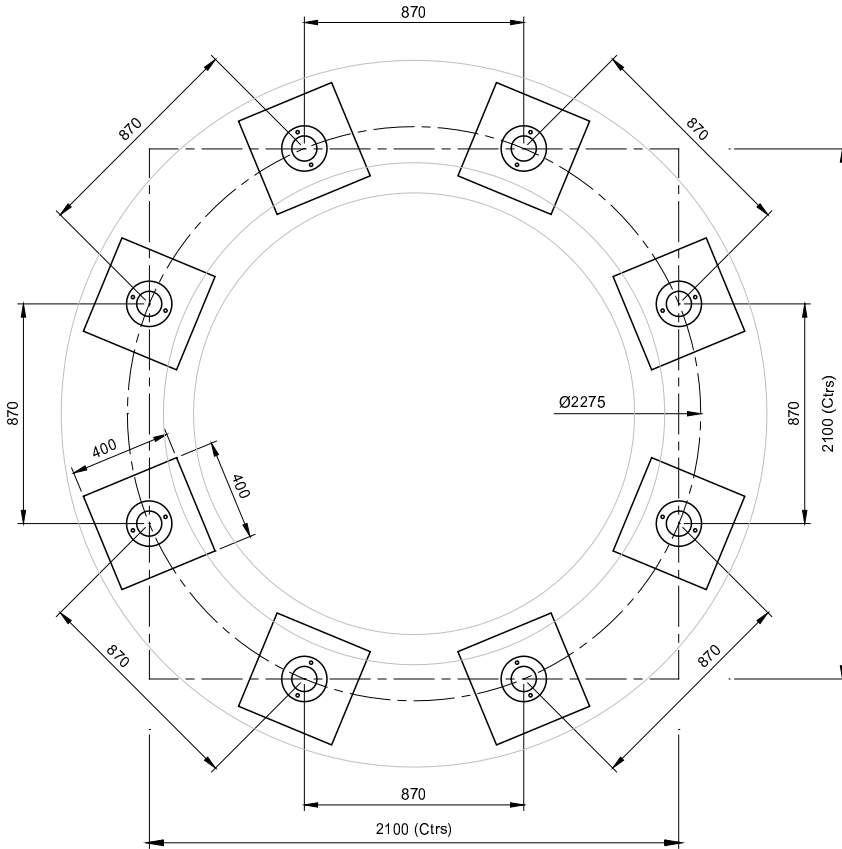

Foundation Pad Set Out
(showing surface fix but same for sub-surface fix)

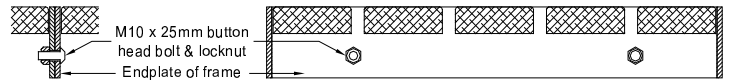
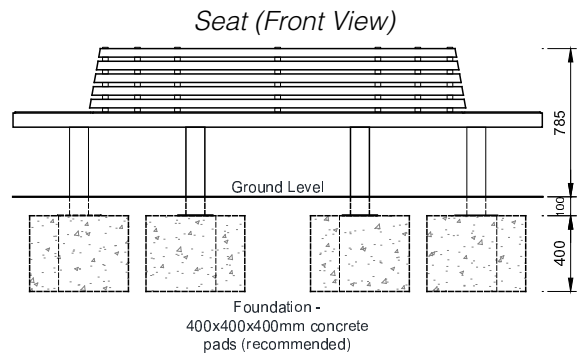
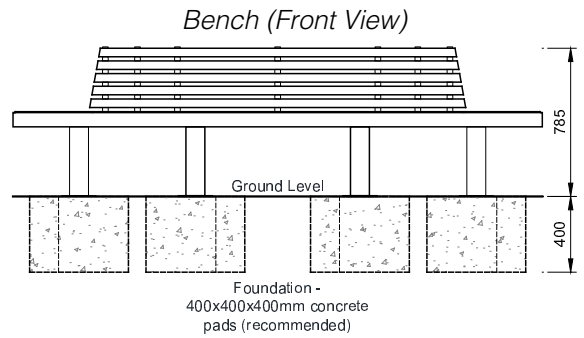

Module Joining Detail

Full Tree Bench / Seat (surface and sub-surface fix)

1. Install suitable foundation pads (see illustration) each with top face at ground level or 100mm below finished ground level for sub-surface fix.
2. Unpack bases and attach to the bench/seat using 2 no. M10 x 25mm button head bolts per base and tighten to 14Nm
3. Assemble 4 no. quarter modules and fix together using 2 no. M10 x 25mm button head bolts per join and tighten to 14Nm (see illustration). For fixing around a tree the seat can be assembled in two halves with final assembly once it's in position
4. Position assembled bench/seat (a crane or forklift will be required at this stage) in correct orientation with bases centrally on foundation pads; mark hole positions through base plates
5. Remove the bench/seat; drill holes $\text{Ø}14\text{mm}$ x 200mm deep (surface fix) or $\text{Ø}12\text{mm}$ x 75mm deep or as manufacturer's recommendations (sub-surface fix).
6. Clear debris from holes.
- 7a. (Surface fix) Fill the holes to within approximately 35mm from the top with Hilti HY150 resin (or similar). Lift the bench/seat (with threaded anchor rods/capnuts in place) and carefully lower the anchors into the holes, leave for two hours to set.
- 7b. Using a torque wrench, tighten nuts and washers over flange plates to 30Nm to fasten down the bench/seat.
8. (Sub-surface fix) Reposition bench/seat unit and fix each base to foundation pads using 2 no. zinc-coated M10 x 75mm sleeve anchors tightened to 50Nm (or as per manufacturer's instruction). Ensure bench/seat remains level during fixing process.
9. Check level & re-instate ground level if necessary

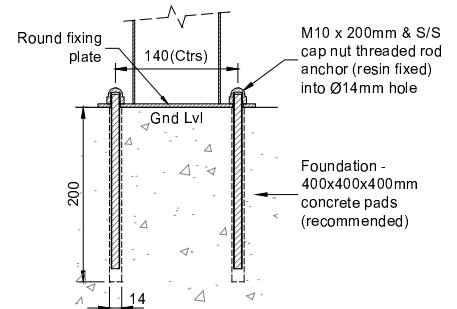

Surface Fix Detail

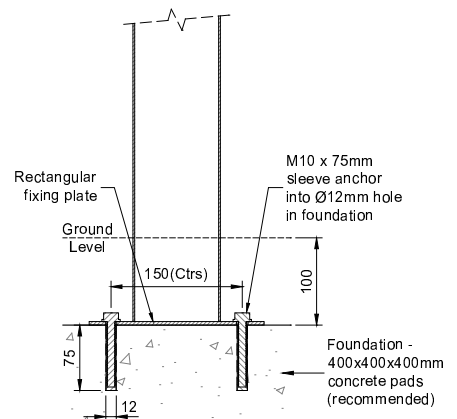

Sub-surface Fix Detail

IMPORTANT NOTE:

Ensure that stainless steel is protected during site cutting of stone – contamination from disc cutters will produce corrosion on stainless steel components.