

FACTORY FURNITURE

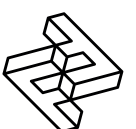

Murton Table

OPERATION & MAINTENANCE MANUAL



Introduction

Design

Design, shop drawings and development by Factory Furniture Ltd.

Manufacture

Factory Furniture manufactured components. Products are assembled in Factory workshops, checked and dispatched ready for installation. Replacement products or components thereof should be ordered direct from Factory Furniture Ltd.

Copyright

The design copyright for the product and drawing copyright remains the sole property of Factory Furniture Ltd.

General Specifications

Table

Metric length 2020mm | width 825mm | height 720mm

Imperial length 6' 7½" | width 2' 8½" | height 2' 4½"

Approx Weight 158kg

Fixing Centres 1920mm (6' 3½") x 600mm (1' 11½")

Picnic Table

Metric length 2020mm | width 1650mm | height 720mm

Imperial length 6' 7½" | width 5' 5" | height 2' 4½"

Approx Weight 241kg

Fixing Centres 1920mm (6' 3½") x 600mm (1' 11½")

The Murton table can be combined with a couple of Murton benches to create an outdoor dining set

Detailed Material & Finish Specifications

Table Slats (inc. seat slats on picnic table only)

- Manufactured from FSC® certified tropical hardwood
- Profiled and left untreated as standard (*oil or microporous woodstain treatment available on request*)
- Supported on frame - attached with 4 no. fixing points each



Frame

- Manufactured from stainless steel - satin polished finish (mild steel option available - hot dipped galvanised with polyester powder coat finish (*powder coat colour grey as standard or to customer specification*))
- Frame is a welded construction
- Anchored to ground using 2 no. resin fixed M10 x 200mm threaded rods and cap nuts per base (*4 off total*)

General Maintenance

(Recommended Schedule & Guidelines)

Daily/Weekly/Monthly (or as adopted)

Visual checks of timber table slats and frame - check all items for superficial or physical damage

Three Monthly

Clean all items as detailed below check all fixings are seated correctly; inspect timber for serious damage and splinters.

Six Monthly

Secure all fixings; full clean as detailed below; check that table is firmly secured to the ground

Specific Maintenance Details

FSC Timber

Clean with a stiff brush once per year, especially in more exposed locations, in order to prevent a verdigris type build up on the timber surface. Ideally this should be completed in early spring. During the cleaning stage, all exposed timber surfaces should be inspected for splits and splinters. Any splinters and graffiti should be removed and the surface sanded with 100 grit sandpaper in order to remove any uneven / sharp edges or surfaces.

During the first few months after installation the tannin naturally occurring in the timber may leach out and cause a brown staining in the bases. This may be removed with a light solution of household bleach and water.

Stainless Steel (polished stainless steel only)

Clean as required, but at least every three months, using a stainless steel polish and a lint free cloth. To remove ground in dirt, a stainless steel finishing pad may be required.

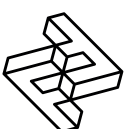

Polyester Powder Coated & Galvanised

For general cleaning using a damp cloth and warm soapy water only. Scourers and abrasive cleaners are NOT suitable for this type of finish and may damage it. Before using any cleaning agents to remove graffiti etc. try on a small, inconspicuous area first to avoid causing more unsightly damage.

Repairs

FSC Timber

For light damage, please see section on specific maintenance details above. For instances of heavy damage, the timber item should be replaced. Please order against the part number reference in the reordering section towards the end of this manual.

Stainless Steel

Light damage (surface scratches etc.) can be removed using an emery pad (240 grit) and freeing oil such as 'WD40'. Care should be taken to follow the direction of the brushing grain. It is recommended that a trial repair be carried out on an unimportant surface first. No corrosive cleaners or other abrasives should be used. Any contamination, particularly carbon teal scuffs from vehicles, should be quickly removed to avoid corrosion.

Polyester Powder Coated & Galvanised Surfaces

For light damage (scratches, chips etc.) repair using touch-up paint to match original colour (available from Factory Furniture Ltd). Paint application should be carried out in accordance with approved methods detailed by the paint manufacturer. Please note that it is advisable to use professional painters to achieve best results when touching up larger areas. Products for respraying larger areas are available from Factory Furniture Ltd.

Heavy Damage

In the event of serious damage to any component, replacements should be ordered from Factory Furniture Ltd. In this event (or if the product needs to be disassembled for any reason), please contact Factory Furniture for detailed technical advice.

Reordering / Spares

(Part No. & Item Description)

P2006 / 01

1 no. Murton table slat set (not including frame) - (2 no. outer slats & 4 no. inner slats total)

P2006 / 02

1 no. Murton picnic table slat set (not including frame) - (2 no. outer table slats, 4 no. inner table slats & 4 no. seat slats total)

Instructions For Reordering

If possible, please specify job name or number at the time of reordering to enable identification of details such as the original species of timber used, stainless steel finishes and polyester powder coat colours etc. In any event where either, additional orders are required, or spares and replacements are required please contact Factory Furniture Ltd. Using the part numbers given above as reference should help us to process your enquiry more efficiently.

Note - All fittings required to assemble ordered parts will automatically be included in the order.

AutoCAD Drawing List

FF2006 / 01

MURTON TABLE
OVERVIEW DRAWING

FF2006 / 01.5

MURTON PICNIC TABLE
OVERVIEW DRAWING

FF2006 / 02

MURTON TABLE
X-SECTION DRAWINGS

FF2006 / 02.5

MURTON PICNIC TABLE
X-SECTION DRAWINGS

FF2006 / 03

MURTON TABLE
TIMBER PARTS DETAIL DRAWINGS

FF2006 / 04

MURTON PICNIC TABLE
STEEL PARTS DETAIL DRAWINGS

FF2006 / 05

MURTON PICNIC TABLE
SETTING OUT DRAWING

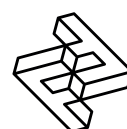

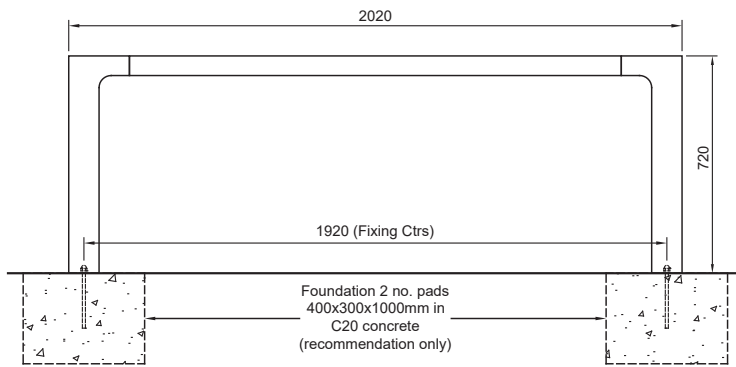

Table

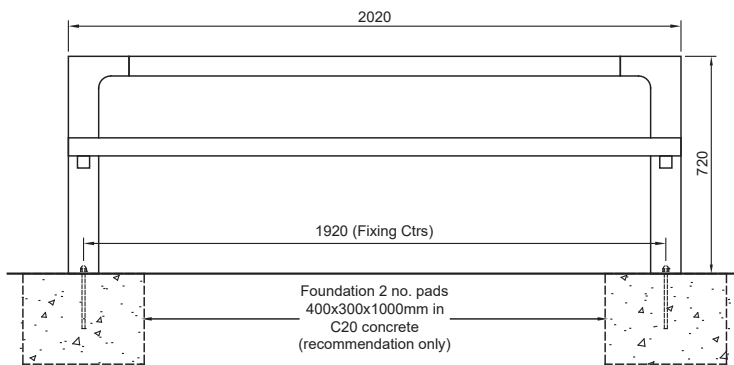
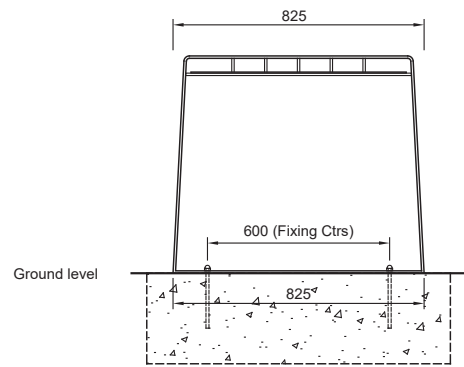

Picnic Table

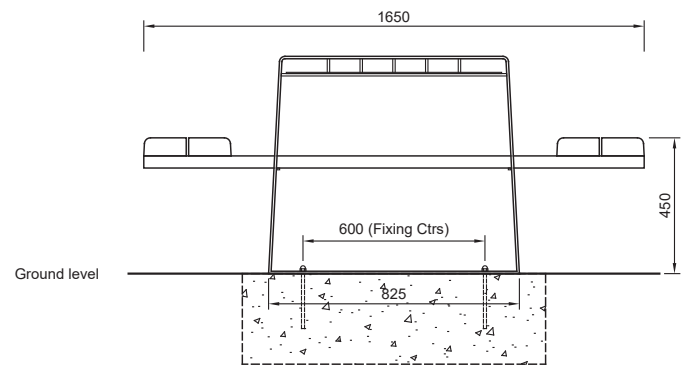

Installation Instructions

All installation works to be carried out by competent personnel - install as complete unit.

Murton Table & Picnic Table

1. Install suitable foundation pads (see illustration) each with top face at ground level
2. Position table in correct orientation with bases centrally on foundation pads, then mark hole positions through base plates.
3. Remove the table; drill holes $\varnothing 14\text{mm} \times 220\text{mm}$ deep
4. Clear debris from holes.
5. Fill the holes to within approximately 35mm from the top with Hilti HY150 resin (or similar). Lift the table (with threaded anchor rods/capnuts in place) and carefully lower the anchors into the holes, leave for two hours before using.

6. Using a torque wrench, tighten nuts and washers over flange plates to 30Nm to fasten down the table.
7. Check level

IMPORTANT NOTE

Ensure that stainless steel is protected during site cutting of stone – contamination from disc cutters will produce corrosion on stainless steel components.

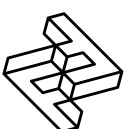
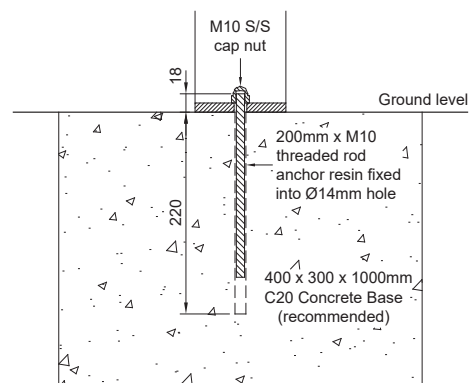

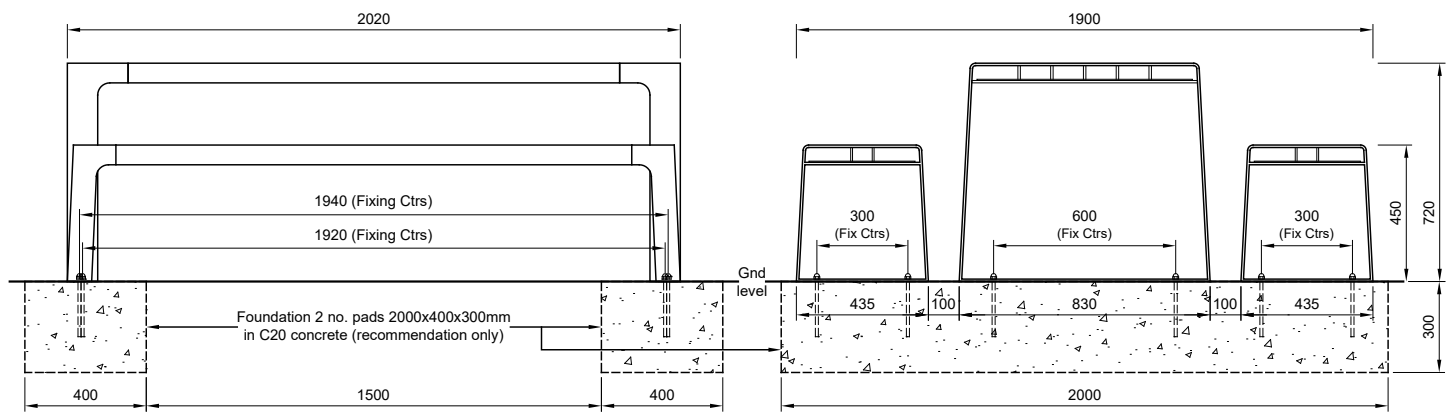

Setting out dimensions

Installation Instructions

All installation works to be carried out by competent personnel - install as complete unit.

Murton Outdoor Dining Set (Wood) (surface fix)

1. Install suitable foundation pads (see illustration) each with top face at ground level
2. Position table and benches in correct orientation with bases centrally on foundation pads, then mark hole positions through base plates.
3. Remove the table and benches; drill holes $\text{\O}14\text{mm}$ x 220mm deep
4. Clear debris from holes.
5. Fill the holes to within approximately 35mm from the top with Hilti HY150 resin (or similar). Lift the table and benches (with threaded anchor rods/capnuts in place) and carefully lower the anchors into the holes, leave for two hours before using.
6. Using a torque wrench, tighten nuts and washers over flange plates to 30Nm to fasten down the table and benches.
7. Check level

IMPORTANT NOTE

Ensure that stainless steel is protected during site cutting of stone – contamination from disc cutters will produce corrosion on stainless steel components.

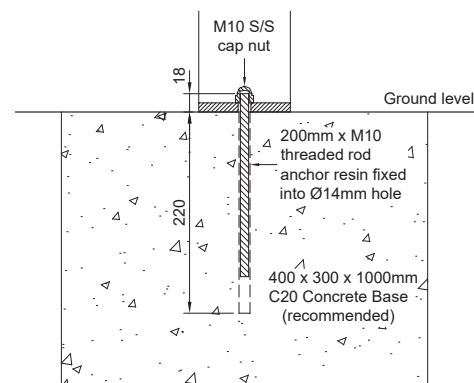

5 Pioneer Road, Faringdon,
Oxfordshire SN7 7BU
+44 (0)1367 242731
hello@factoryfurniture.co.uk

factoryfurniture.co.uk

