



RailRoad SEATING & TABLES



Public realm furniture design
& innovation from Furnitubes



RAILROAD SEATING & TABLE RANGE



© Furnitubes Ref: S-525-02116



**SMART
SPACE®**

SmartSpace is an innovative approach to public realm furniture, whereby products are designed and can be arranged to meet the varying and changing requirements of outdoor spaces. RailRoad is the latest addition to the **SmartSpace** family.

www.furnitubes.com



tel: 020 8378 3200

INTRODUCTION

The ultimate in flexible seating design

As the name suggests, RailRoad is inspired by train tracks, and model train sets to be more precise - a series of straight and curved raised platforms that can be joined to form continuous seating runs, and can also be used independently for a coordinated suite of products across a scheme. In between the scale of a full size rail track and a model railway, this simple idea has been designed and engineered by Furnitubes' in-house design team and is precision-manufactured to ensure inter-changeability of seating assemblies. This integral flexibility provides a vast range of seating configuration options - from straight line seating, to circular layouts, other geometric patterns and also flowing organic forms - all achievable with standard components. This approach means that bespoke configurations can be supplied at very much standard prices. Furthermore, there are 3 styles in the range, each suiting different environments.

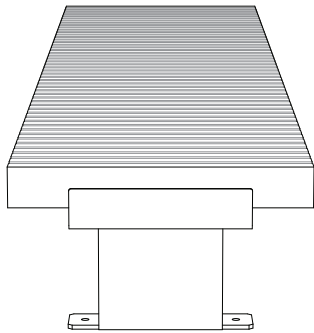

RailRoad
EDGE

Square-form timbers define the sharp visual characteristics of the **EDGE** family - a popular choice on contemporary architectural developments. The support posts are in a complementary open-ended box fabricated in plate steel that gives a very heavy duty and robust aesthetic.

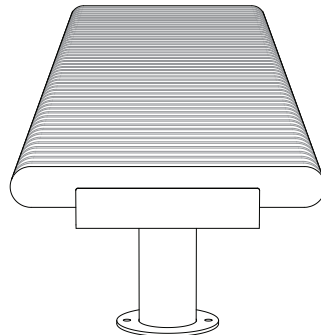

RailRoad
LOOP

The side profile of the bench slat is reminiscent of a lollipop stick, hence the abbreviated **LOOP** name given to this family. The rounded-end slats offer a greater degree of comfort for the sitter and with a central circular support post is visually softer than other options.

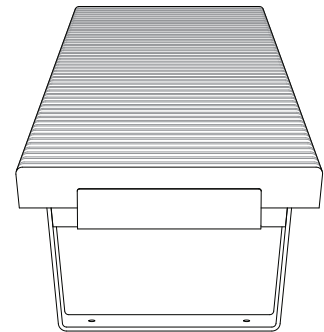

RailRoad
DELTA

Angled-back slat ends and a complementary profile to the under-seat support characterises the refined aesthetics of the **DELTA** family within the RailRoad range. The rounded leading edge to the bench slats also provides comfortable long term seating provision.

RAILROAD SEATING RANGE

Design principles and built-in features

RailRoad is based on a simple series of inter-changeable straight and curved modules, which are designed to be joined to create seamless runs of continuous seating. The design is based around a standard module that comfortably accommodates 2 people, with the start and end units also including small extension sections at one end. Just like with a model train track, straights and curves can be mixed to create interesting configurations. A double-end unit offers a small independent seating solution to complement longer assemblies. Double width seating and complementary planters, which can be added at any point along a seating run, are the latest additions to the range.

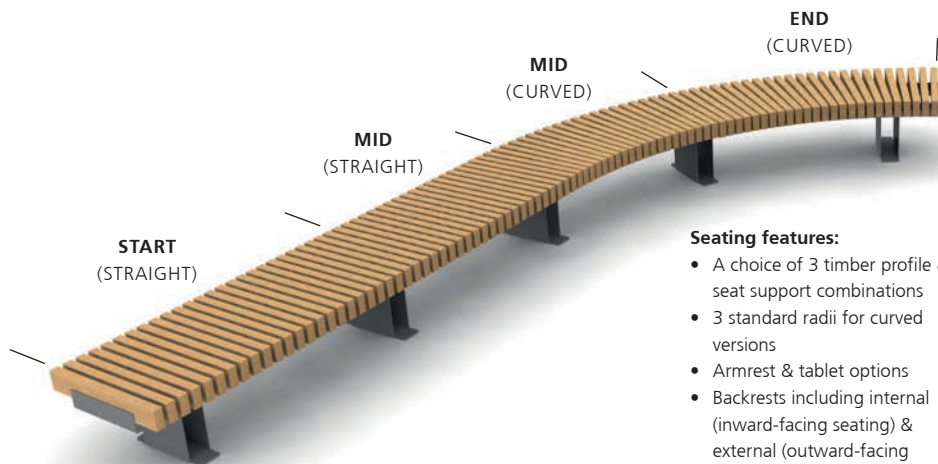

Seating features:

- A choice of 3 timber profile & seat support combinations
- 3 standard radii for curved versions
- Armrest & tablet options
- Backrests including internal (inward-facing seating) & external (outward-facing seating) on curved modules
- Chaise-longue additions to straight benches

Planter features:

- Can be added at the start / end or within a seating run
- A choice of 4 lengths and 2 height options
- Straight and curved seating units can be joined to planters
- Use in conjunction with any seat support type (but only square-ended 'Edge' timbers)
- Can also be used as independent planters

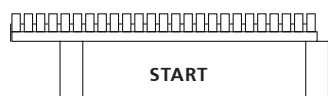

1 platform (including end extension)
+ 2 supports

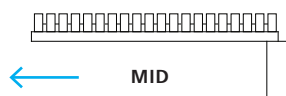

1 platform + 1 support

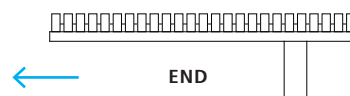

1 platform (including end extension)
+ 1 support

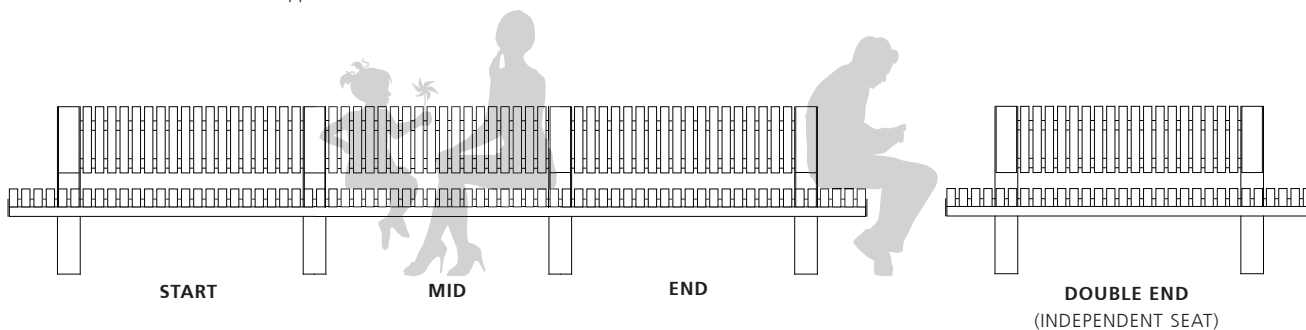

RAILROAD SEATING RANGE

Standard dimensions: **straight 2-person module**

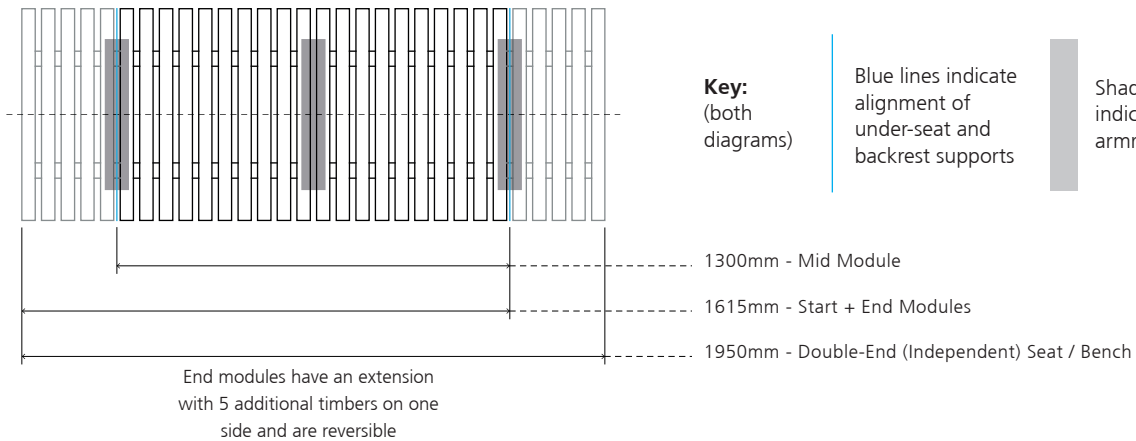

Key:
(both diagrams)

Blue lines indicate alignment of under-seat and backrest supports

Shaded boxes indicate standard armrest positions

Standard dimensions: **curved 2-person module**

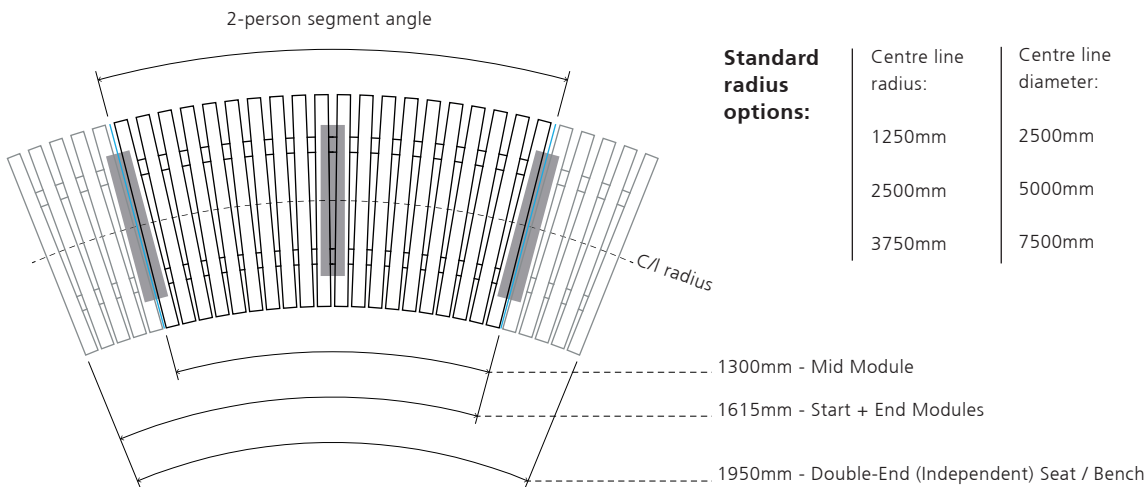

Standard radius options:

Centre line radius:	Centre line diameter:	2-person segment angle:
1250mm	2500mm	60 deg
2500mm	5000mm	30 deg
3750mm	7500mm	20 deg

Left hand end modules have an extension with 5 additional timbers on the left hand side

Right hand end modules have an extension with 5 additional timbers on the right hand side

Note: dimensions are arc lengths along centre lines and are common to all seat radii options (segment angles vary with radius)

RAILROAD SEATING RANGE

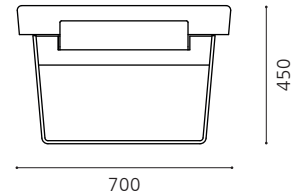
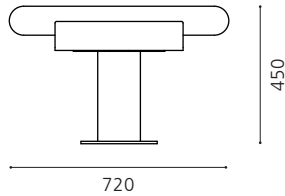
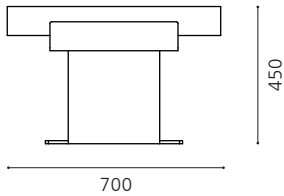

RailRoad EDGE

RailRoad LOOP

RailRoad DELTA

General specification all models: steel frame & seat supports for bolt-down surface fixing, hot dip galvanised, with iroko timber seat slats

OPTIONS (All models - Edge, Loop & Delta, except where stated otherwise):

- Backrest - straight and curved (internal and external)
- Armrest - all-steel or steel with iroko top
- Tablet surface - 350mm wide, steel with iroko top
- Chaise longue backrest, single and double-sided, iroko slats over steel frame
- Polyester powder coated steelwork to any RAL reference
- Timbers with UV protective finish
- Combining different supports & timbers, e.g. 'Edge' timbers + 'Loop' supports
- Extended depth supports for in-ground installation (not Delta)



RAILROAD SEATING RANGE



RAILROAD STRAIGHT BENCHES

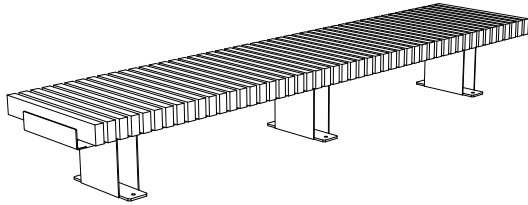

MODEL ILLUSTRATED:
RRBES7 S + RRBES7 E (3250mm long)

RAILROAD EDGE STRAIGHT BENCH

2-PERSON MODULES

Start module, 1615mm long	RRBES7 S
Mid module, 1300mm long	RRBES7 M
Mid module (no legs), 1300mm long	RRBXS7 M
End module, 1615mm long	RRBES7 E

INDEPENDENT BENCHES

1950mm long	RRBES7 1950
3250mm long	RRBES7 S + RRBES7 E

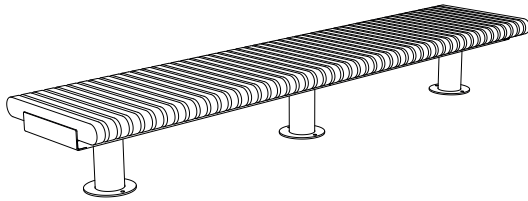

MODEL ILLUSTRATED:
RRBLR7 S + RRBLR7 E (3250mm long)

RAILROAD LOOP STRAIGHT BENCH

2-PERSON MODULES

Start module, 1615mm long	RRBLR7 S
Mid module, 1300mm long	RRBLR7 M
End module, 1615mm long	RRBLR7 E

INDEPENDENT BENCHES

1950mm long	RRBLR7 1950
3250mm long	RRBLR7 S + RRBLR7 E

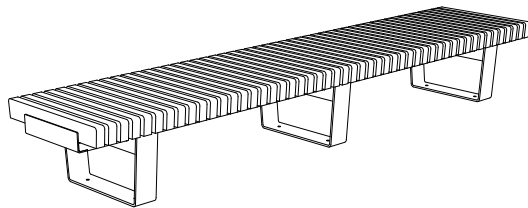

MODEL ILLUSTRATED:
RRBDA7 S + RRBDA7 E (3250mm long)

RAILROAD DELTA STRAIGHT BENCH

2-PERSON MODULES

Start module, 1615mm long	RRBDA7 S
Mid module, 1300mm long	RRBDA7 M
End module, 1615mm long	RRBDA7 E

INDEPENDENT SEATS

1950mm long	RRBDA7 1950
3250mm long	RRBDA7 S + RRBDA7 E

RAILROAD CURVED BENCHES

Note: lengths for curved modules correspond with equivalent straight benches, with lengths measured along bench centre line

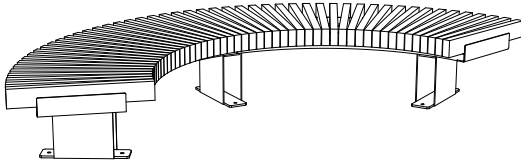

MODEL ILLUSTRATED:
RRBES7 SR125 + RRBES7 EL125 (3250mm long c/l)

RAILROAD EDGE CURVED BENCH

2-PERSON MODULES	R1.25m C/L	R2.50m C/L	R3.75m C/L
Start module left hand	RRBES7 SL125	RRBES7 SL250	RRBES7 SL375
Start module right hand	RRBES7 SR125	RRBES7 SR250	RRBES7 SR375
Mid module	RRBES7 M125	RRBES7 M250	RRBES7 M375
End module left hand	RRBES7 EL125	RRBES7 EL250	RRBES7 EL375
End module right hand	RRBES7 ER125	RRBES7 ER250	RRBES7 ER375

INDEPENDENT UNITS

1950mm long bench	RRBES7 125	RRBES7 250	RRBES7 375
3250mm long bench	RRBES7 SR125 + RRBES7 EL125	RRBES7 SR250 + RRBES7 EL250	RRBES7 SR375 + RRBES7 EL375

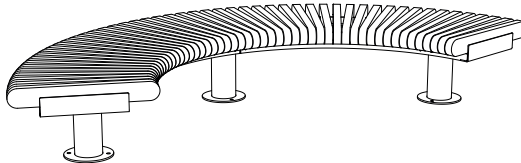

MODEL ILLUSTRATED:
RRBLR7 SR125 + RRBLR7 EL125 (3250mm long c/l)

RAILROAD LOOP CURVED BENCH

2-PERSON MODULES	R1.25m C/L	R2.50m C/L	R3.75m C/L
Start module left hand	RRBLR7 SL125	RRBLR7 SL250	RRBLR7 SL375
Start module right hand	RRBLR7 SR125	RRBLR7 SR250	RRBLR7 SR375
Mid module	RRBLR7 M125	RRBLR7 M250	RRBLR7 M375
End module left hand	RRBLR7 EL125	RRBLR7 EL250	RRBLR7 EL375
End module right hand	RRBLR7 ER125	RRBLR7 ER250	RRBLR7 ER375

INDEPENDENT UNITS

1950mm long bench	RRBLR7 125	RRBLR7 250	RRBLR7 375
3250mm long bench	RRBLR7 SR125 + RRBLR7 EL125	RRBLR7 SR250 + RRBLR7 EL250	RRBLR7 SR375 + RRBLR7 EL375

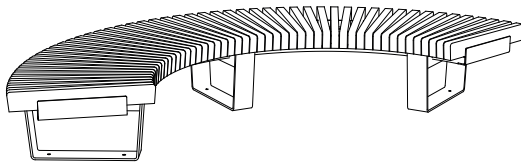

MODEL ILLUSTRATED:
RRBDA7 SR125 + RRBDA7 EL125 (3250mm long c/l)

RAILROAD DELTA CURVED BENCH

2-PERSON MODULES	R1.25m C/L	R2.50m C/L	R3.75m C/L
Start module left hand	RRBDA7 SL125	RRBDA7 SL250	RRBDA7 SL375
Start module right hand	RRBDA7 SR125	RRBDA7 SR250	RRBDA7 SR375
Mid module	RRBDA7 M125	RRBDA7 M250	RRBDA7 M375
End module left hand	RRBDA7 EL125	RRBDA7 EL250	RRBDA7 EL375
End module right hand	RRBDA7 ER125	RRBDA7 ER250	RRBDA7 ER375

INDEPENDENT UNITS

1950mm long bench	RRBDA7 125	RRBDA7 250	RRBDA7 375
3250mm long bench	RRBDA7 SR125 + RRBDA7 EL125	RRBDA7 SR250 + RRBDA7 EL250	RRBDA7 SR375 + RRBDA7 EL375

RAILROAD BACKRESTS

All standard 2-person bench modules are designed to accommodate backrests, meaning they can be fitted at the outset or retro-fitted after installation if the need for a backrest is determined later. Backrests align with the bench supports, and are therefore inset from the ends of bench platforms. On long seat assemblies, backrests can be continuous or with gaps, or even staggered to both sides for dual aspect seating. All of the different backrest options (straights and external / internal curves of all radii) can be adjoined to provide a continuous back support. Shown here are various layouts and the terminology that we use to ensure that the correct backrests are provided in the correct positions. RailRoad backrests are common to all Edge, Loop and Delta bench products.

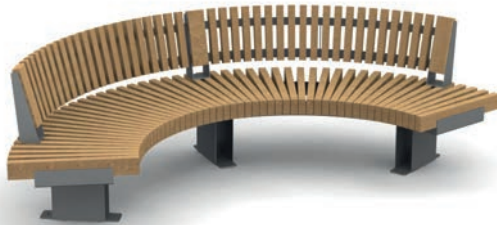

Curved external backrests

When the backrest is on the outside of a curved seat we refer to this as an external backrest, with people facing inwards towards the centre point of the seat radius.



Curved internal backrests

When the backrest is on the inside of a curved seat we refer to this as an internal backrest, with people facing outwards away from the centre point of the seat radius.



Combined curved external & internal backrests

On wave layout seating, a continuous backrest on one side requires both external & internal backrests, joined at the change of direction junction on the bench, all of which is achievable with standard components.

RAILROAD BACKRESTS

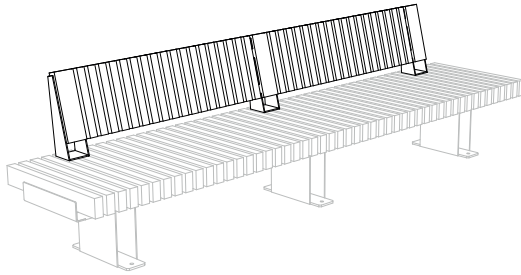

BACKRESTS ILLUSTRATED:
RRBACK S + RRBACK E

STRAIGHT BACKRESTS

2-PERSON MODULES

Start module	RRBACK S
Mid module	RRBACK M
End module	RRBACK E

INDEPENDENT UNITS

1950mm long bench	RRBACK
3250mm long bench	RRBACK S + RRBACK E

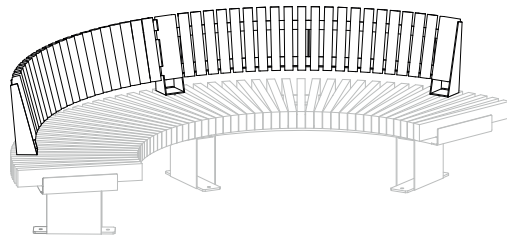

BACKRESTS ILLUSTRATED:
RRBACK S125E + RRBACK E125E (on Edge bench 1.25m c/l radius)

CURVED EXTERNAL BACKRESTS

2-PERSON MODULES	R1.25m C/L	R2.50m C/L	R3.75m C/L
Start module	RRBACK S125E	RRBACK S250E	RRBACK S375E
Mid module	RRBACK M125E	RRBACK M250E	RRBACK M375E
End module	RRBACK E125E	RRBACK E250E	RRBACK E375E

INDEPENDENT UNITS

1950mm long bench	RRBACK 125E	RRBACK 250E	RRBACK 375E
3250mm long bench	RRBACK S125E + RRBACK E125E	RRBACK S250E + RRBACK E250E	RRBACK S375E + RRBACK E375E

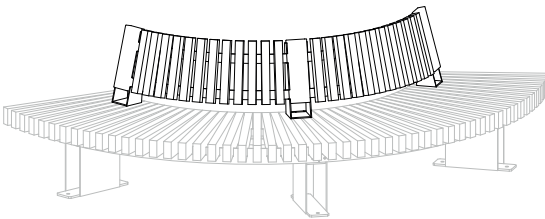

BACKRESTS ILLUSTRATED:
RRBACK S125N + RRBACK E125N (on Edge bench 1.25m c/l radius)

CURVED INTERNAL BACKRESTS

2-PERSON MODULES	R1.25m C/L	R2.50m C/L	R3.75m C/L
Start module	RRBACK S125N	RRBACK S250N	RRBACK S375N
Mid module	RRBACK M125N	RRBACK M250N	RRBACK M375N
End module	RRBACK E125N	RRBACK E250N	RRBACK E375N

INDEPENDENT UNITS

1950mm long bench	RRBACK 125N	RRBACK 250N	RRBACK 375N
3250mm long bench	RRBACK S125N + RRBACK E125N	RRBACK S250N + RRBACK E250N	RRBACK S375N + RRBACK E375N

RAILROAD SEATING RANGE



RAILROAD ARMRESTS

Standard armrests

Constructed from robust 80mm wide steel plate, standard armrests can be fitted between any two timber slats on a bench or seat, although aligning them with bench platform supports and at midpoints between will ensure comfortable spacings. There is one style specifically designed for use with benches (although these can also be used with seats if preferred), and another for seats with backrests. Armrests can be easily retro-fitted if required.



570mm - gap between armrests

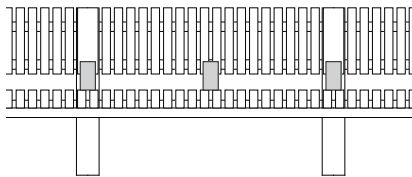

1300mm pitch
2-person module

RAILROAD STANDARD ARMREST

RRA B
Armrest for bench

RRA S
Armrest for seat (with backrest)

Timber-topped armrests

The addition of a timber slat to a steel armrest aids its use, improves comfort and looks good. The timber rail extends beyond the front of the steel armrest support, thereby providing a good grip area for less able-bodied people in particular to assist when lowering themselves onto or lifting off from the seats. A timber armrest is also warmer to the touch. At 110mm wide, the flat timber is suitable for placing small items such as a coffee cup onto.



540mm - gap between armrests

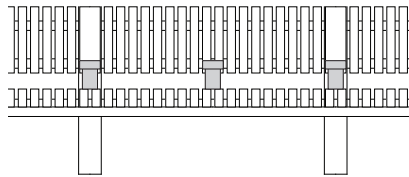

1300mm pitch
2-person module

RAILROAD TIMBER-TOPPED ARMREST

RRAT B
Armrest for bench

RRAT S
Armrest for seat (with backrest)

Tablet surfaces

It is increasingly common for people to carry a small laptop or tablet device, and to use them in the outdoor environment. At 350mm wide, the tablet (a small side table) is a useful addition to a bench, suitable for placing not only computer devices onto, but also food and drink, a book or newspaper. When using a tablet it is not advisable to use armrests in standard positions as the gaps between would be too narrow for comfortable seating.



950mm - gap between tablets

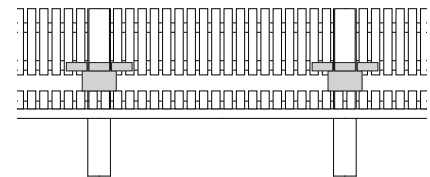

1300mm pitch
2-person module

RAILROAD TABLET SURFACE

RRTT B
Tablet for bench

RRTT S
Tablet for seat (with backrest)

RAILROAD CHAISE LONGUE

Relax, put your feet up!

All RailRoad straight benches can be fitted with a chaise longue backrest, allowing users to put their feet up to relax and enjoy the outdoors, especially in the summer months. Chaise longue backrests can be fitted at any position along a bench, although we would recommend aligning them on the segment divisions as shown below to maximise the amount of useful seating space. Longer assemblies obviously give room to really stretch out and also lend themselves to the double-sided versions.

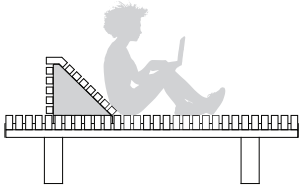

One module independent bench with chaise longue backrest

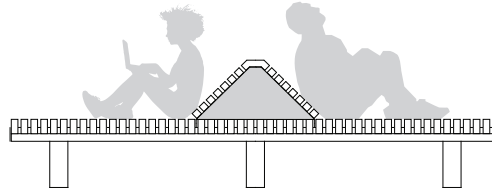

A two module bench also has space for back-to-back chaise longue seating

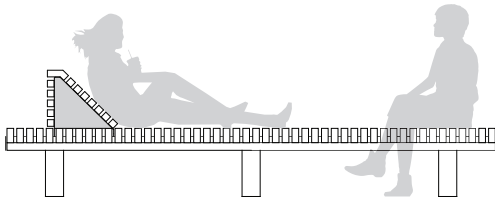

A two module bench allows room for chaise longue and regular seating

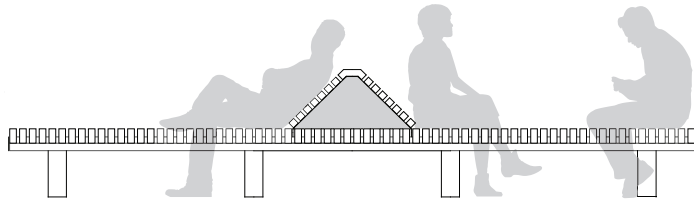

Three modules with back-to-back chaise longue and regular seating

RAILROAD CHAISE LONGUE BACKREST

RRCH1

Single-sided backrest

RRCH2

Double-sided backrest

RAILROAD CHAISE LONGUE



RAILROAD DOUBLE WIDTH SEATING

Double platforms and back-to-back seating

At 1400mm wide, double width benches are large enough to be considered as small platforms that people can sit in the middle of, as well as around the edges. For safe handling the platform itself is divided into 2 sub-assembled parts, each essentially the same as the standard width platform, and available with all the same add-on options, including backrests, armrests and tablet surfaces. Double width platforms are also offered in the same 3 styles - Edge, Loop and Delta - as for standard seating, with the steel supports designed as complementary double width versions. Benches and seats can be used as independent units and joined together to form longer runs, and also combined with planters in an endless array of configuration options. As with all RailRoad range products, modularity and interchangeability comes as standard.

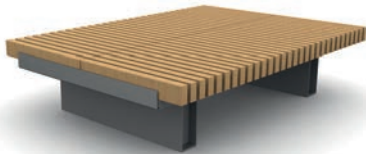
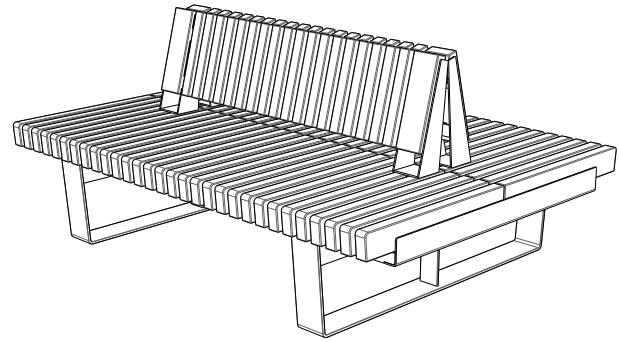

RailRoad EDGE DOUBLE WIDTH

Square-form timbers define the sharp visual characteristics of the **EDGE** family. Platform supports are a closed-end steel box fabrication (these are open-ended on the standard width units) that gives a very heavy duty and robust aesthetic, and most often supplied in a galvanised only finish, which is popular on municipal schemes in particular.



RailRoad LOOP DOUBLE WIDTH

The rounded-end profile of the bench slats, combined with circular support posts are the distinctive features of the **LOOP** version of the RailRoad. The slats offer a greater degree of comfort for the sitter and a visually softer appearance than for other options making the design suited to sites where people sit for longer.

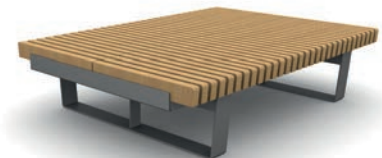

RailRoad DELTA DOUBLE WIDTH

Gently angled-back edge slats and a complementary profile to the under-seat support characterises the refined aesthetics of the **DELTA** version of the RailRoad range. The extra span of the platform necessitates the addition of a central vertical plate that isn't used on the standard width seating.

RAILROAD GALLERY



RAILROAD CIRCULAR SEATING

RailRoad in the round

Curved seating, and circular arrangements in particular, are an increasingly popular choice on many landscape schemes. Inward facing curves offer greater sociability compared with linear seating, and outward facing seating is often used to encircle a prominent feature on a site, such as a specimen tree. The modular design of the RailRoad range is ideal for circular arrangements and we offer 3 standard diameters - 2.5m, 5m and 7.5m (all measured on the seating platform centre line). These sizes all divide up to give common module lengths based on a 2-person segment. Varying the combinations of Start, End and Mid Modules (and Double-Ends on some layouts) gives a wide variety of circular options, including fully enclosed circles, horseshoes with a single opening and circles with gaps for access into the central area. Part-circles can also be achieved by reducing the number of component seating modules. The extensive range of options shown comprise standard modules throughout, meaning that circular seating from the RailRoad range can be supplied at very competitive prices compared with bespoke designs. Internal or external backrests (or a mix of both) are compatible with all models and further options include armrests and tablet surfaces.

Note: Seating arrangements that contain End Modules include an extension section to one end, which adds approximately 300mm to the centre line length of a 2-person segment. If there is an armrest at the end of the 2-person segment the extension can serve as a narrow perch-type seat. Without any armrests this area is a seamless extension of the main seating platform. Seating capacities as shown do not include for any additional seating provided by the extension area.



RAILROAD CIRCULAR SEATING

ENCLOSED CIRCLES

Full circular arrangements are ideal around site features such as trees, where users sit facing outwards and access to the central area is not needed.

HORSESHOES

Circular arrangements with a single gap allow access to the central space and are popular as exterior teaching areas in school grounds.

OPEN CIRCLES (NARROW GAPS)

Narrow gaps in circular arrangements are suitable for occasional access to the central area. The gaps serve to visually break up large volumes of seating.

OPEN CIRCLES (WIDE GAPS)

Wider gaps allow wheelchair access to the central area, making these arrangements the most versatile in terms of their use.

Ø2.50m CIRCLE C/L (SEAT C/L RADIUS 1.25m)



6 x Mid Modules
Seats 12 people



1 x Start Module
2 x Mid Modules
1 x End Module
Seats 8 people
Gap = 1275mm



2 x Start Modules
2 x End Modules
Seats 8 people
Gaps = 465mm



2 x Double End Modules
Seats 4 people
Gaps = 1275mm

Ø5.0m CIRCLE C/L (SEAT C/L RADIUS 2.50m)

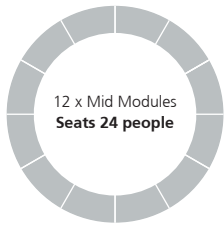

12 x Mid Modules
Seats 24 people

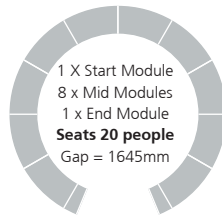

1 X Start Module
8 x Mid Modules
1 x End Module
Seats 20 people
Gap = 1645mm

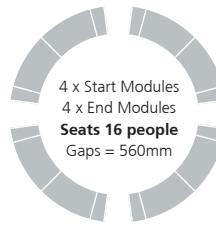

4 x Start Modules
4 x End Modules
Seats 16 people
Gaps = 560mm



3 x Start Modules
3 x End Modules
Seats 12 people
Gaps = 1645mm

Ø7.5m CIRCLE C/L (SEAT C/L RADIUS 3.75m)

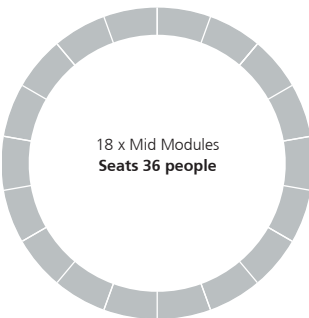

18 x Mid Modules
Seats 36 people

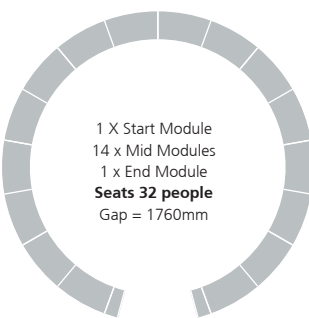

1 X Start Module
14 x Mid Modules
1 x End Module
Seats 32 people
Gap = 1760mm

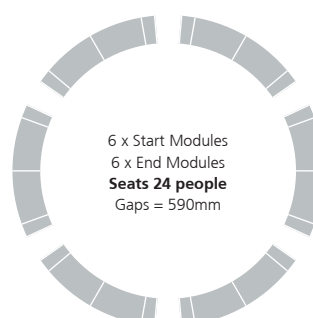

6 x Start Modules
6 x End Modules
Seats 24 people
Gaps = 590mm

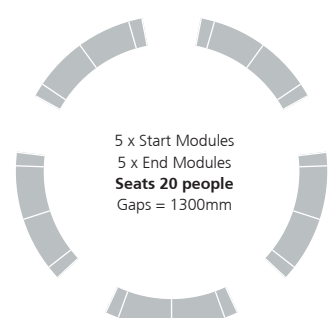

5 x Start Modules
5 x End Modules
Seats 20 people
Gaps = 1300mm

RAILROAD WAVE SEATING



Seating with a twist

As with circular seating, wave-form / serpentine shapes are a popular choice for external seating provision, and are often employed in double aspect situations, where sitters can choose which way to view their surroundings. From just 3 standard radius options, a wide variety of wave forms can be offered by introducing changes of direction to the individual modules at different points - creating a visual range from gentle waves to accentuated peaks and troughs. The examples shown opposite all use common modular seats in a single arrangement, meaning the pattern has a distinct visual geometry. Different radius seating modules can be joined to form more organic layouts.

As across the entire RailRoad range, there are 3 styles of seating offered - Edge, Loop and Delta - all of which are available with a range of optional add-on features, such as armrests, tablet surfaces and backrests.

Note: Seating arrangements that contain End Modules include an extension section to one end, which adds approximately 300mm to the centre line length of a 2-person segment. If there is an armrest at the end of the 2-person segment the extension can serve as a narrow perch-type seat. Without any armrests this area is a seamless extension of the main seating platform. Seating capacities as shown do not include for any additional seating provided by the extension area.

RAILROAD WAVE SEATING

ALTERNATE DIRECTIONS

Changing the direction of adjacent curved seating modules results in a low profile wave layout, which provides a subtle variation to straight seating, without taking up too much space. All layouts shown provide 4 seating places.

2-SEGMENT DIRECTION CHANGES

Adjacent curved seats paired in the same direction accentuate the form of the wave, creating a more distinct S-shape layout, particularly on the tight radius models. These compact layouts provide a minimum of 8 seating places for good social seating provision.

3-SEGMENT DIRECTION CHANGES

Groups of 3 curved seat modules in the same direction give a pronounced wave dynamic. Each layout shown below is a continuous seat that will accommodate at least 12 people and makes a significant visual statement on any site. These seats are ideal for busy sites where people take time to enjoy their surroundings. Tighter radius modules give the impression of two adjoined half circles, whereas the more relaxed curves create elongated S-shapes.

C/L RADIUS 1.25m MODULES



3510 x 1025mm o/a

1 x Start Module
1 x End Module
Seats 4 people



5255 x 1950mm o/a

1 x Start Module
2 x Mid Modules
1 x End Module
Seats 8 people



5700 x 3200mm o/a

1 x Start Module
4 x Mid Modules
1 x End Module
Seats 12 people

C/L RADIUS 2.50m MODULES



3475 x 865mm o/a

1 x Start Module
1 x End Module
Seats 4 people



5970 x 1370mm o/a

1 x Start Module
2 x Mid Modules
1 x End Module
Seats 8 people



8060 x 2165mm o/a

1 x Start Module
4 x Mid Modules
1 x End Module
Seats 12 people

C/L RADIUS 3.75m MODULES



3425 x 815mm o/a

1 x Start Module
1 x End Module
Seats 4 people



6030 x 1150mm o/a

1 x Start Module
2 x Mid Modules
1 x End Module
Seats 8 people



8455 x 1705mm o/a

1 x Start Module
4 x Mid Modules
1 x End Module
Seats 12 people

RAILROAD GEOMETRIC SEATING ISLANDS

Ovals & triangles

Circular enclosures - utilising common modules throughout - are popular seating layouts in many landscape schemes but so much so are now considered quite ordinary. With the RailRoad there is the option of mixing the module types to create more unusual layouts. Shown here is an oval comprising modules of 2 different radii, and a triangular arrangement achieved by adding straight line modules between the curves - all using standard modules, meaning these more distinctive arrangements cost no more than the equivalent-sized circles.

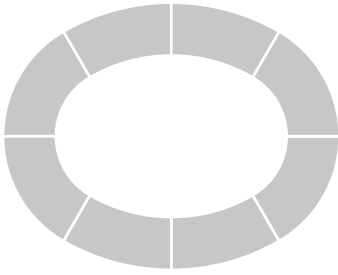

OVAL

4 x R1.25m Curved Mid Modules
4 x R2.5m Curved Mid Modules
Seats 16 people
4450mm x 3540mm o/a

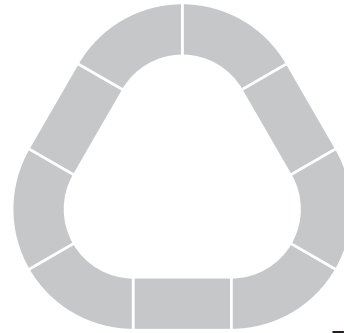

TRIANGLE

3 x Straight Mid Modules
6 x R1.25m Curved Mid Modules
Seats 18 people
4500mm x 4330mm o/a

Wavy-edged islands

Re-orientating selected modules in the opposite direction to the predominant curve creates a wavy-line edge to these seating arrangements. The figure of eight layout lends itself to perhaps 2 internal specimen trees - one in each lobe, and similarly the triangular version could accommodate 3 internal trees. Curved seating in general, and alternating the orientation of seating in particular, creates more semi-private spaces that encourages use of the seating, as people sitting alongside each other can face in slightly different directions.

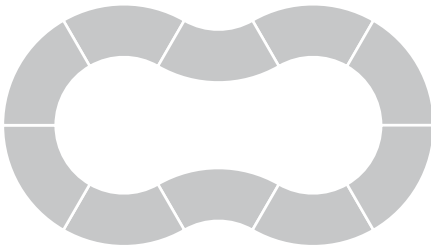
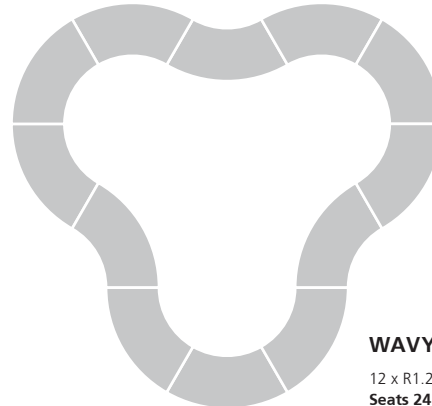

FIGURE OF EIGHT

10 x R1.25m Curved Mid Modules
Seats 20 people
5700mm x 3200mm o/a



WAVY-EDGED TRIANGLE

12 x R1.25m Curved Mid Modules
Seats 24 people
5700mm x 5370mm o/a

RAILROAD GEOMETRIC SEATING ISLANDS

Propellers

These layouts combine double width straight seats on each arm of the propeller, joined by curved modules in the centre to give three seating orientations. The central gap is relatively small, meaning these layouts would suit placement around features such as a column, or perhaps a street clock. The geometry of the propeller allows multiple forms to be used together to create even larger scale honeycomb-type arrangements.

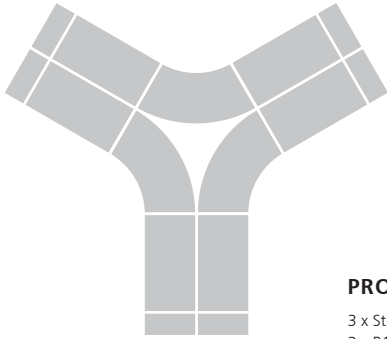

PROPELLER

3 x Straight Double Width End Modules
3 x R1.25m Curved Mid Modules
Seats 18 people
5100mm x 4420mm o/a (Ø5090mm)

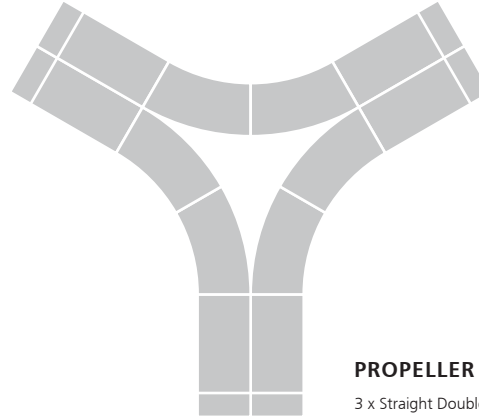

PROPELLER EXTENDED

3 x Straight Double Width End Modules
6 x R2.5m Curved Mid Modules
Seats 24 people
6350mm x 5500mm o/a (Ø6525mm)

Open eyes

Straight line continuous seating might be considered fairly monotonous, offering only a single aspect (or double if back-to-back) that may have to be 'broken' where there are site features in the way. By adding curved modules the seating can divert around existing site features and also presents a far more visually interesting seating solution. When used in a back-to-back arrangement as shown on the examples here, the seats are an unusual variation to a circular tree seat, that would be suited to a linear street layout as it takes up much less space than a full circle.

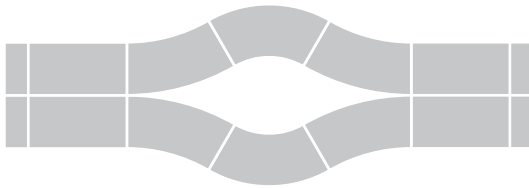

OPEN EYE

2 x Straight Double Width End Modules
6 x R1.25m Curved Mid Modules
Seats 20 people
6980mm x 2400mm o/a

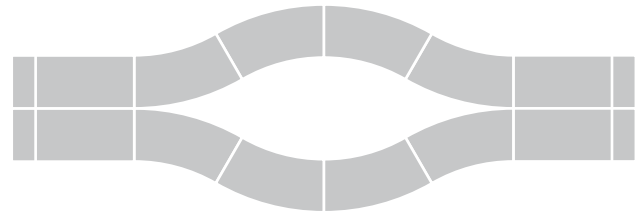

OPEN EYE EXTENDED

2 x Straight Double Width End Modules
8 x R2.5m Curved Mid Modules
Seats 24 people
8230mm x 2740mm o/a

RAILROAD ORGANIC LAYOUTS

Endless possibilities

Just like with a model train track, the layout options with RailRoad seating are almost endless, with all straight and curved modules being interchangeable. Backrests can be fitted in long runs or just to selected modules, and armrests and tablets can be fitted at any point along the seating run. Whilst the example layout shown here is unlikely to be a serious proposition for any site, it demonstrates the flexibility offered by the RailRoad seating range. The only model train track components not scaled up for the RailRoad range are points, buffers and signals!

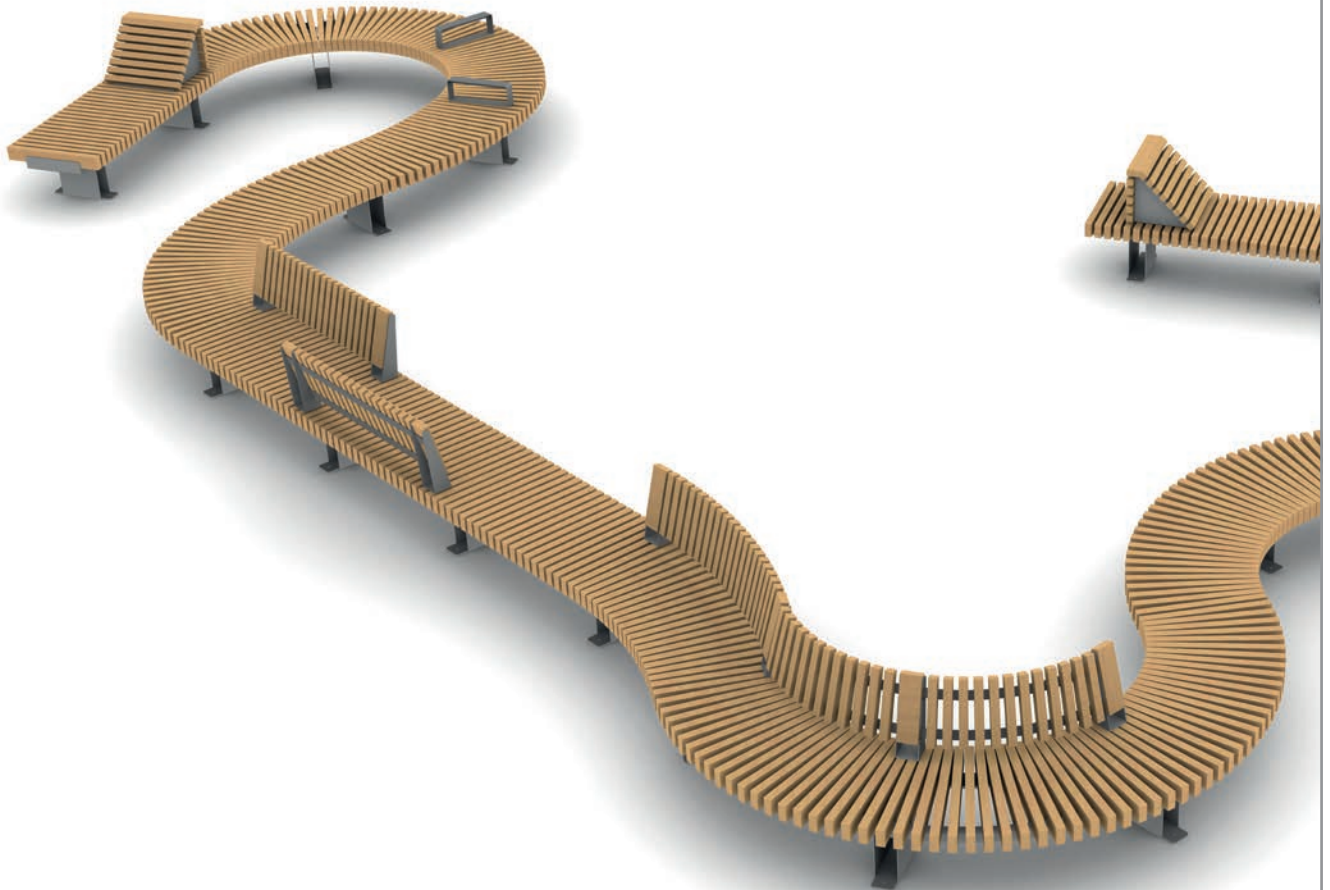

RAILROAD ORGANIC LAYOUTS

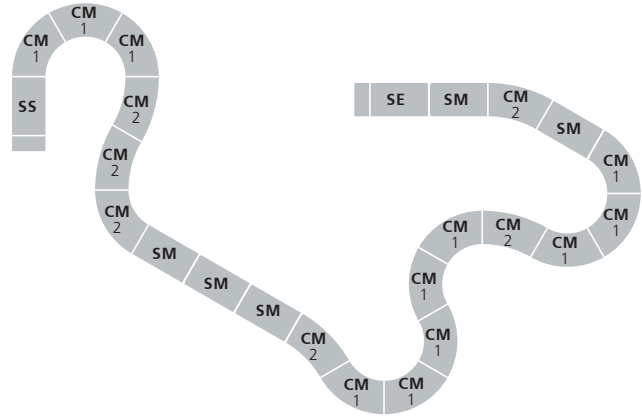

Key: basic bench modules on example configuration shown:

- SS** Straight Start
- SM** Straight Mid
- SE** Straight End
- CM 1** Curved Mid, 1.25m c/l radius
- CM 2** Curved Mid, 2.50m c/l radius

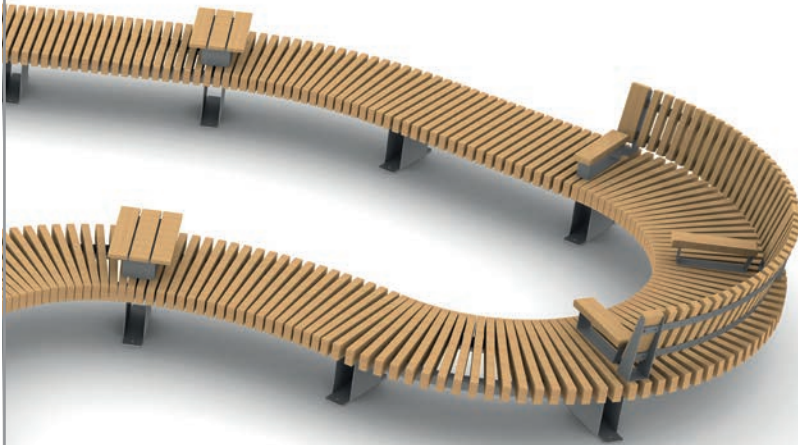

All aboard the RailRoad!

If you have a requirement for a site-specific layout, our designers are happy to visualise the configuration for you. Simply let us know the approximate overall area that you have available, the forms and features that you are interested in, and leave the rest to us.

RAILROAD SCHEME DESIGN

Case study: University of Leicester Brookfield Campus

Brookfield - a satellite site to the central campus - is a recent acquisition that the University of Leicester is developing to offer supplementary and upgraded teaching facilities and office accommodation for support staff. The site comprises a mixture of historic buildings and distinctive late twentieth century constructions with enclosed courtyards. One of these courtyards is the first area to be redeveloped at Brookfield, designed to offer an external rest and relaxation area, or even be used as a meeting space when the weather is suitable, by the Estates Management team staff from the surrounding offices. When selecting seating for the scheme, landscape architects Barry Chinn Associates truly embraced the modular concept of RailRoad, so much so that the setting out of the perimeter planting beds was dictated by the seating sizes. Three separate seats were supplied, each comprising different radii modules that introduce a refreshing informality to the courtyard, especially compared to the very linear layout of the space previously. The seating is further enhanced by the addition and informal placement of backrests, armrests and tablet surfaces, which are useful for placing paperwork, laptops, or simply a coffee on. Unusually, the seating combines straight-cut 'Edge' timbers with the round post 'Loop' seat supports.

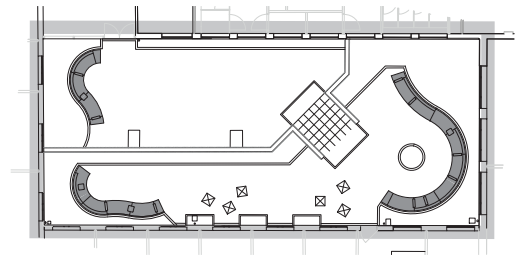

RAILROAD SCHEME DESIGN



RAILROAD SCHEME DESIGN

Case study: Research Triangle Park, North Carolina, USA

The Research Triangle Park (RTP) is one of the most prominent high-tech research and development parks in the United States, centred on the three hub cities of Raleigh, Durham, and Chapel Hill, and their research universities. RTP was created in 1959 by state and local governments, academic establishments and local businesses and is now home to over 200 companies employing 50,000 workers, including the second largest IBM operation in the world, and GlaxoSmithKline's largest R & D centre, all within 10 square miles of pine forest setting. Although buildings and roadways divide and traverse the park, expanses of the original forest remain, providing an attractive outdoor environment for the staff to use at break times and even for informal meetings. RailRoad seating was chosen for one such area as its inherent flexible design allows endless configuration options that could be arranged around the trees and other existing site features. The Loop version - with its round-ended timber slats and circular post supports - visually complemented the environment, and was the simplest of the RailRoad styles to supply with extended legs to allow in-ground installation on the undulating ground. The steelwork was finished in a vibrant green, to contrast with the deeper tones of the surrounding pine trees. Letterform cycle stands spelling 'EAT' were installed near to the seating, with other words used elsewhere around the park.

Letterform

Designed as cycle stands but also used to spell out words and create interesting landscape features at the Research Triangle Park.

THINK

EAT
PLAY
REST
THINK
WAG



RAILROAD SCHEME DESIGN



Key to modules:

- CS 1** Curved Start, 1.25m c/l radius
- SS** Straight Start
- SM** Straight Mid
- CM 1** Curved Mid, 1.25m c/l radius
- CM 2** Curved Mid, 2.50m c/l radius
- CE 1** Curved End, 1.25m c/l radius
- SE** Straight End



RAILROAD INLINE SEATING

Straight line seating

RailRoad Inline is designed as a cost effective alternative to the original RailRoad product range for independent and continuous run straight line only seating. Timber slats on the seat platform and backrest are re-orientated to run in line with the seat length, meaning less machining, eradicating the need for a full length steel support chassis, and with supports at a wider span. As with RailRoad there are 3 styles of seat supports - Edge, Loop and Delta - each with the ends of the timber slats machined in a complimentary profile. Seat assemblies are supplied as starter, mid and end modules to allow long lines of visually seamless continuous seating, with backrests, armrests and tablet surfaces all available as optional extras on all models. Even more effective seating solutions are offered by the RailRoad Inline narrow width bench options.



RailRoad In-line seating

Refer to our RailRoad Inline-specific e-brochure at the link below for details and examples of the full range of standard options offered within the range.

https://issuu.com/furnitubes/docs/furnitubes_e-038-01-16_railroad_inl?e=1460965/32526874



RAILROAD INLINE SEATING



RAILROAD NARROW BENCHES

Compact, cost effective benches

At around 700mm wide, the standard width RailRoad seating platforms offer a generous seating area, allowing people to perch on both sides at the same time. This width also allows for backrests to be added within the overall width of the seat. Where only benches (seating without backrests) are required, and / or there are budgetary constraints, the RailRoad Narrow Bench range is an alternative solution.



STANDARD BENCH

allows perch seating from both sides

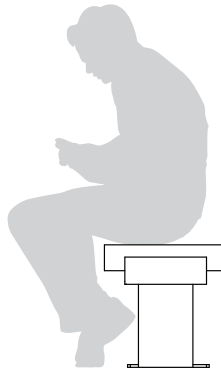

NARROW BENCH

suits one person on each part at any one time



All 3 standard RailRoad styles - Edge, Loop and Delta - are offered in straight versions and 3 curved sizes in the RailRoad Narrow Bench range of products. The design principles and geometry remain as for the standard width bench, allowing all the same inter-changeability and configuration layout options, including:

- Straight lines
- Circles - enclosed, open and horsehoes
- Wave-forms
- Organic combinations of any of the above

RAILROAD NARROW BENCHES

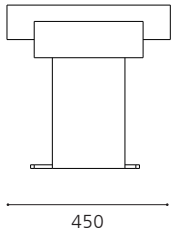

RailRoad EDGE NARROW

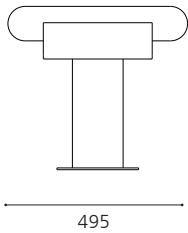

RailRoad LOOP NARROW

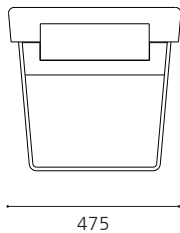

RailRoad DELTA NARROW

RAILROAD NARROW BENCHES GENERAL SPECIFICATION

Steel frame & seat supports for bolt-down surface fixing, hot dip galvanised, with iroko timber seat slats

OPTIONS:

- Extended depth supports for in-ground installation (not Delta)
- Armrests - all-steel or steel with iroko top
- Tablet - 350mm wide, steel with iroko top
- Polyester powder coated steelwork to any RAL reference
- Timbers with UV protective finish
- Square-ended 'Edge' timber slats with Loop & Delta supports



RAILROAD NARROW STRAIGHT BENCHES

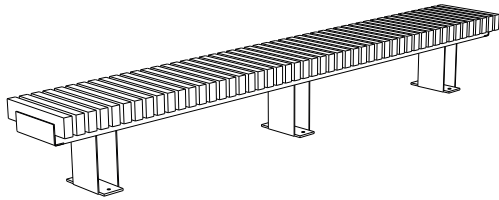

MODEL ILLUSTRATED:
RRBESN S + RRBESN E (3250mm long)

RAILROAD EDGE STRAIGHT NARROW BENCH

2-PERSON MODULES

Start modules, 1615mm long	RRBESN S
Mid modules, 1300mm long	RRBESN M
End modules, 1615mm long	RRBESN E

INDEPENDENT BENCHES

1950mm long	RRBESN 1950
3250mm long	RRBESN S + RRBESN E

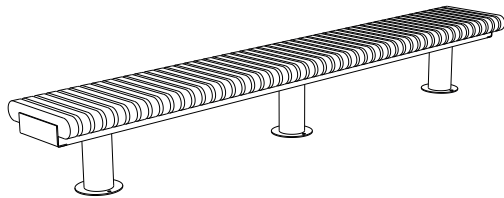

MODEL ILLUSTRATED:
RRBLRN S + RRBLRN E (3250mm long)

RAILROAD LOOP STRAIGHT NARROW BENCH

2-PERSON MODULES

Start modules, 1615mm long	RRBLRN S
Mid modules, 1300mm long	RRBLRN M
End modules, 1615mm long	RRBLRN E

INDEPENDENT BENCHES

1950mm long	RRBLRN 1950
3250mm long	RRBLRN S + RRBLRN E

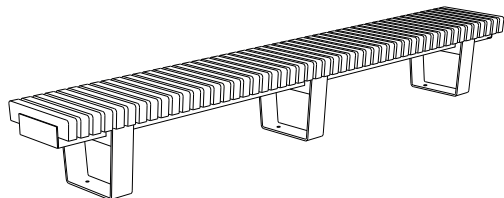

MODEL ILLUSTRATED:
RRBDAN S + RRBDAN E (3250mm long)

RAILROAD DELTA STRAIGHT NARROW BENCH

2-PERSON MODULES

Start modules, 1615mm long	RRBDAN S
Mid modules, 1300mm long	RRBDAN M
End modules, 1615mm long	RRBDAN E

INDEPENDENT SEATS

1950mm long	RRBDAN 1950
3250mm long	RRBDAN S + RRBDAN E

RAILROAD NARROW CURVED BENCHES

Note: lengths for curved modules correspond with equivalent straight benches, with lengths measured along bench centre line

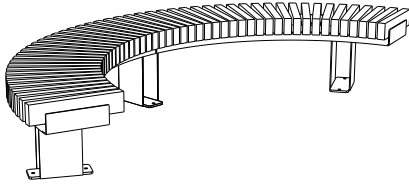

MODEL ILLUSTRATED:
RRBESN SR125 + RRBESN EL125 (3250mm long c/l)

RAILROAD EDGE CURVED NARROW BENCH

2-PERSON MODULES	R1.25m C/L	R2.50m C/L	R3.75m C/L
Start module left hand	RRBESN SL125	RRBESN SL250	RRBESN SL375
Start module right hand	RRBESN SR125	RRBESN SR250	RRBESN SR375
Mid module	RRBESN M125	RRBESN M250	RRBESN M375
End module left hand	RRBESN EL125	RRBESN EL250	RRBESN EL375
End module right hand	RRBESN ER125	RRBESN ER250	RRBESN ER375

INDEPENDENT BENCHES

1950mm long	RRBESN 125	RRBESN 250	RRBESN 375
3250mm long	RRBESN SR125+ RRBESN EL125	RRBESN SR250+ RRBESN EL250	RRBESN SR375+ RRBESN EL375

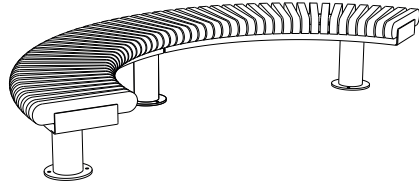

MODEL ILLUSTRATED:
RRBLRN SR125 + RRBLRN EL125 (3250mm long c/l)

RAILROAD LOOP CURVED NARROW BENCH

2-PERSON MODULES	R1.25m C/L	R2.50m C/L	R3.75m C/L
Start module left hand	RRBLRN SL125E	RRBLRN SL250E	RRBLRN SL375E
Start module right hand	RRBLRN SR125E	RRBLRN SR250E	RRBLRN SR375E
Mid module	RRBLRN M125E	RRBLRN M250E	RRBLRN M375E
End module left hand	RRBLRN EL125E	RRBLRN EL250E	RRBLRN EL375E
End module right hand	RRBLRN ER125E	RRBLRN ER250E	RRBLRN ER375E

INDEPENDENT BENCHES

1950mm long	RRBLRN 125E	RRBLRN 250E	RRBLRN 375E
3250mm long	RRBLRN SR125E+ RRBLRN EL125E	RRBLRN SR250E+ RRBLRN EL250E	RRBLRN SR375E+ RRBLRN EL375E

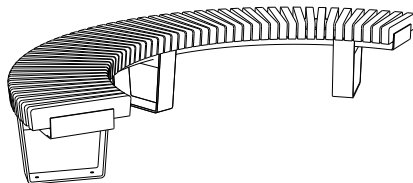

MODEL ILLUSTRATED:
RRBDAN SR125 + RRBDAN EL125 (3250mm long c/l)

RAILROAD DELTA CURVED NARROW BENCH

2-PERSON MODULES	R1.25m C/L	R2.50m C/L	R3.75m C/L
Start module left hand	RRBDAN SL125N	RRBDAN SL250N	RRBDAN SL375N
Start module right hand	RRBDAN SR125N	RRBDAN SR250N	RRBDAN SR375N
Mid module	RRBDAN M125N	RRBDAN M250N	RRBDAN M375N
End module left hand	RRBDAN EL125N	RRBDAN EL250N	RRBDAN EL375N
End module right hand	RRBDAN ER125N	RRBDAN ER250N	RRBDAN ER375N

INDEPENDENT BENCHES

1950mm long	RRBDAN 125N	RRBDAN 250N	RRBDAN 375N
3250mm long	RRBDAN SR125N + RRBDAN EL125N	RRBDAN SR250N+ RRBDAN EL250N	RRBDAN SR375N+ RRBDAN EL375N

RAILROAD TABLES

Tables for a coordinated scheme

RailRoad tables are designed to complement the seating range, with heavy duty iroko timber slats fixed to tough galvanised steel support structures. The table top platform is mounted on a choice of 3 support options - to match the Edge, Loop and Delta seating units. Tables are offered in a length of 1950mm to comfortably accommodate 3 people on each side, or even 4 people at a slight squeeze. This length corresponds with all standard 'independent' seating options from the RailRoad range, meaning tables can be used with the standard benches, with or without backs, and also the narrow bench versions, which is a popular combination for picnic sites. Two table widths are offered, with the wider versions recommended for outdoor dining provision.



EXAMPLE TABLE & SEATING SET:

Table: RailRoad Edge supports with standard table top
1950mm long x 825mm wide

Benches: RailRoad Edge Narrow independent benches
1950mm long x 450mm wide

- Adequate width for short term use in picnic situations
- Smaller overall width takes up less space



EXAMPLE TABLE & SEATING SET:

Table: RailRoad Edge supports with wide table top
1950mm long x 930mm wide

Seat: RailRoad Edge independent seat with backrest
1950mm long x 700mm wide

Bench: RailRoad Edge independent bench
1950mm long x 700mm wide

- Generous width tables and seating
- Backrest is an optional extra on wide benches
- Ideal for outdoor restaurant dining areas

RAILROAD TABLES

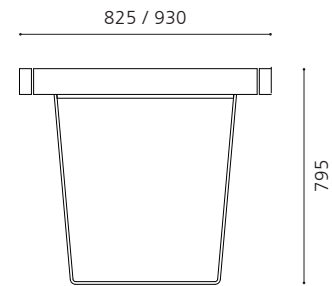
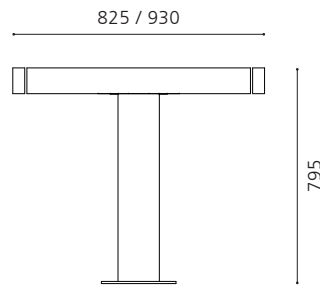
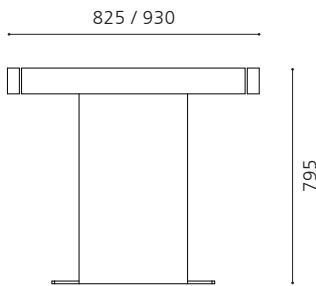
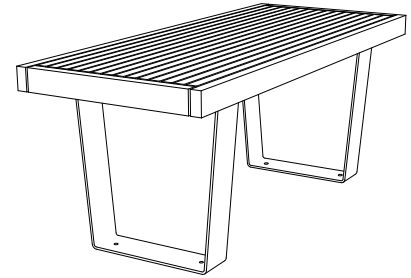
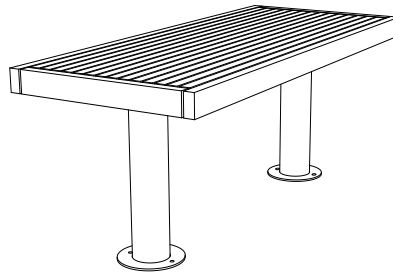
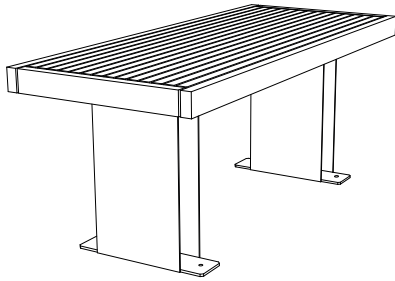

RAILROAD TABLES

Steel frame & seat supports for bolt-down surface fixing, hot dip galvanised, with iroko timber slats

RAILROAD EDGE

RRTE 825

1950mm long x 825mm wide table

RRTE 930

1950mm long x 930mm wide table

RAILROAD LOOP

RRTL 825

1950mm long x 825mm wide table

RRTL 930

1950mm long x 930mm wide table

RAILROAD DELTA

RRTD 825

1950mm long x 825mm wide table

RRTD 930

1950mm long x 930mm wide table

OPTIONS (ALL MODELS):

- Extended depth supports for in-ground installation (not Delta)
- Through socket in table top for parasol
- Polyester powder coated steelwork to any RAL reference
- Timbers with UV protective finish

RAILROAD BESPOKE VARIATIONS

Photo: Simon Khan

International Bomber Command Centre (IBCC)

The IBCC near Lincoln has been created to provide a world-class facility to serve as a point for recognition, remembrance and reconciliation for Bomber Command. The centrepiece to the site is the Memorial Spire designed by Place Architecture, around which a series of walls record all of the Command servicemen who lost their lives during WWII. Between the walls are planters and bespoke back-to-back RailRoad seats, curved-on-plan with the seat slats set out radially from the centre of the spire. Manufactured with a combination of steel support framework in a powder coated grey finish and timber-slatted seats and backrests, the materials compliment the corten steel and gravel landscape palette used on the site. The seats are shown here in the lead-up to and at the opening ceremony in October 2015.

© Furnitubes Ref: S-589-02-16

RAILROAD BESPOKE VARIATIONS



Photo: Ian Clipson (Eclipseonimages)



Photo: Jon Fixter



Photo: Shelagh Wright



Photo: Place Architecture

© Furnitubes Ref: S-590-02-16

RAILROAD BESPOKE VARIATIONS

Haberdashers' Aske's School for Girls

The Excelsior Building is a new addition to the impressive Haberdashers' Aske's School campus in Borehamwood, providing a new performance hall, mezzanine café, function room and general teaching spaces, together with courtyard improvements and roof top terraces. The courtyard comprises planted beds, with social spaces and pathways in a mix of resin-bound gravels and synthetic grass surfaces. To allow pupils to enjoy this new outdoor space a seating system was required that was sufficiently flexible to be able to follow the curves and angles of the planting beds, and RailRoad was the ideal choice. The Delta support version was selected, with site-specific features including square-cut RailRoad 'Edge' style timbers, a reduced width seating surface of 520mm (compared with 700mm of the standard specification and 450mm for the standard narrow width version benches) and the under-seat support platform supplied in stainless steel. In total over 60 linear metres of RailRoad was supplied, for 4 long curvi-linear seating runs and also some shorter independent straight units.



RAILROAD BESPOKE VARIATIONS



RAILROAD INTEGRATED SEATING & PLANTERS

Coordinated planters with integrated seating

Planters are the latest addition to the RailRoad family, building on the popularity of the seating ranges to offer the specifier a wider range of fully coordinated products. As with the seating designs, modularity and flexibility are key, allowing products to be joined in an infinite number of layout combinations. RailRoad planters are amongst the most robust from our entire range - constructed in folded heavy section plate steel with the exterior finished in a tough polyester powder coated finish and a GRP-lined interior - they form a rigid, durable construction designed to stand the test of time. We have considered the sustainability of the planting as well, building in as standard the provision for a gravel drainage / reservoir base and a drainage outlet pipe that can be used or simply capped off if not required. As well as combining with seating, planters can also be used as independent units and are available in a variety of plan sizes and in two standard heights, to be flush with or higher than seating platform level. The robust timber top rim allows the edges of the planters to be safely used as short term perch seating.



RailRoad Planters

Refer to our planter-specific e-brochure at the link below for details and examples of both independent units and planters used in combination with RailRoad seating modules.

http://issuu.com/furnitubes/docs/furnitubes_railroad_planters__seat/1?e=1460965/33262515

RAILROAD INTEGRATED SEATING & PLANTERS



RAILROAD SEATING & PLANTER LINEAR COMBINATIONS

Straight seating module + planter at start / end

Planters can be used at the start / end of a seating run. Cube planters might contain single large specimen plants, whereas troughs offer greater planting opportunities to make a more significant display.



Straight seating modules + planter in mid position

Placing a planter within a seating run serves to break it up into smaller segments, creating more private areas with planting between, which people who are not acquainted are more likely to use than if the seating is a single continuous line.



Straight seating modules + planter as corner unit

Where seats are arranged in L-shapes, the corner section between the two arms is not a very effective seating area. Placing a planter in this area is an ideal use for an otherwise redundant space, and also serves to provide separation between adjacent seats.

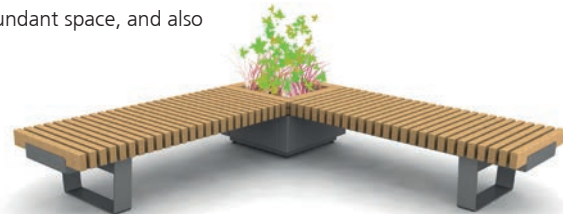

Straight seating module + planters at start / end position

If planters are used at both ends, the seating platform can simply bridge between them. With the weight and stability offered by the planters and their fill material, this type of assembly can generally be left freestanding.



RAILROAD SEATING & PLANTER ISLAND COMBINATIONS

Curved triangle

At 3.2m overall diameter, the smallest size RailRoad seating circle may be too large for some sites. Using 3 curved seating segments with cube planters creates a smaller and more unusual arrangement that suits placement around a tree or other feature.

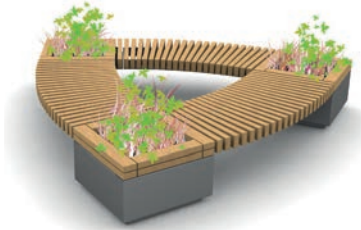

3 x Cube Planters
3 x R2.5m Mid Module Seats
Seats 6 people
2830mm x 2730mm o/a



Round-cornered triangle

A triangular layout is a distinctive variation on a circular enclosure, with trough planters that divide the assembly into smaller sections of seating. If one set of the seating pairs is removed the seating could be used as either inward or outward facing.

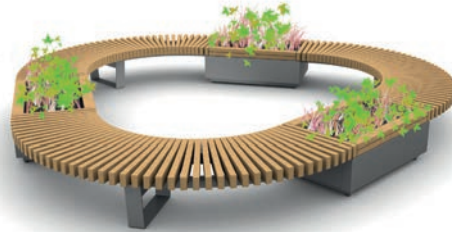

3 x Trough Planters
6 x R1.25m Mid Module Seats
Seats 12 people
4500mm x 4330mm o/a



Ellipse

An ellipse is an alternative to a full circle and takes up less space, using cube planters at the points and curved seating segments between. An attractive shape in its own right, this layout is also suitable for setting out around a specimen tree.

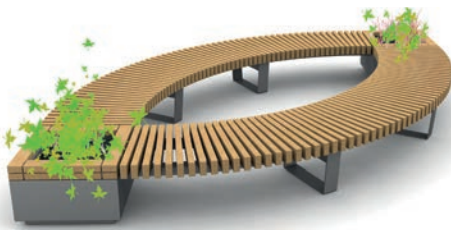

2 x Cube Planters
6 x R2.5m Mid Module Seats
Seats 12 people
5020mm x 2660mm o/a



Propeller

Trough planters at the end of each point offer the opportunity of significant planting, with the 3 sets of paired platforms providing curved seating between. The geometry of this layout even allows multiples to be linked together for further seating provision.

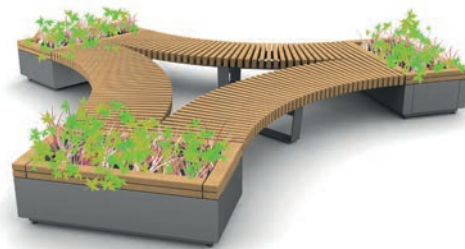

3 x Trough Planters
6 x R1.25m Mid Module Seats
Seats 12 people
4710mm x 4110mm o/a



RAILROAD INTEGRATED SEATING & PLANTERS

Case study: University of Leicester

Fielding Johnson Square lies at the heart of the University of Leicester main campus, flanked by three distinctive 1960s high rise buildings, including the Engineering Building - the first major construction by renowned British architect Sir James Stirling. Created on the site of a former car park, the square has become the university's main public realm space and pedestrian crossroads, designed as an outdoor meeting place for staff, students and visitors. Earlier works included new paving, soft landscaping and lighting, powerpoints and WiFi infrastructure. The latest phase of works has introduced extensive seating and planter provision, all required to be freestanding so it can be moved around the square according to the space required for events such as Freshers' week. Furnitubes' RailRoad range of planters and seating was the ideal choice for this application, as modules can be joined together (and also readily disassembled) to create large stable structures without the need to permanently fix them to the ground. To aid manoeuvrability, planters were designed with higher-than-normal feet to allow access beneath for a low level pallet truck to quickly move the products around the site. In addition to the RailRoad range, other products supplied to the scheme include Hollo stools, bespoke Elements Goalpost table and bench picnic sets, and Arca dual compartment litter and recycling bins.

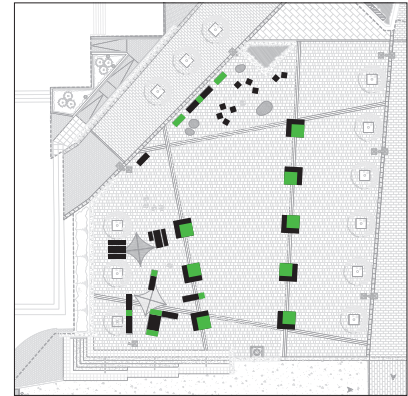

RAILROAD INTEGRATED SEATING & PLANTERS



RAILROAD INSTALLATION

Standard bolt-down fixing

All benches, seats and tables are fitted with a base plate to all supports, pre-drilled for M10 or M12 ground anchors. Surface-mounted bolt-down installation suits sites where the ground is relatively level and where the existing substrate is of sufficient mass and stability to fix into or where new foundation blocks can be laid.

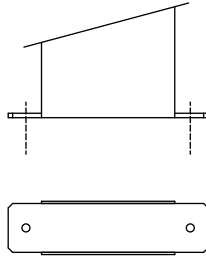

RailRoad
EDGE

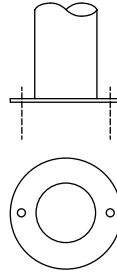

RailRoad
LOOP

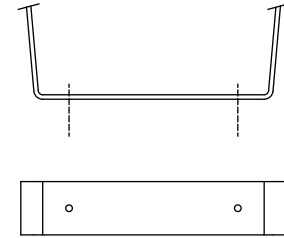

RailRoad
DELTA

Alternative fixing methods

Where the ground slopes, a standard bolt-down installation may not be suitable, as seating and table top surfaces would echo the falls of the ground level. There are two alternative base / installation options that can be supplied on RailRoad Edge and Railroad Loop products, both of which enable horizontal surfaces to be installed true plumb even on sloping ground. For the RailRoad Delta range of products the tapered faces of the supports are less suited to below ground fixing as variable installation depths on adjacent supports would result in an inconsistent appearance; Delta products are therefore best suited to bolt-down installation onto level ground.

Below ground bolt-down (Edge & Loop)

Steel supports can be extended in depth, with a base plate for bolting down to a concrete foundation block set below the finished paving level, and at sufficient depth to allow paving to be overlaid. All steel supports are generally supplied at the same height, meaning foundation blocks must be set true plumb rather than at a constant depth below finished ground level. The main advantage of this method is that the product can be fairly easily removed without the need to break out a full concrete foundation.

Cast-in post support (Edge & Loop)

Steel supports can be supplied at extended lengths for setting into a concrete foundation block. This method is a relatively quick and easy installation, but removal of the product can be disruptive as the finished surface as well as the concrete have to be broken out and excavated.

Products for either of these installation methods are designed and manufactured to the dimensions to suit your site. Other site-specific details can be designed and supplied as required.

RAILROAD SEATING & TABLE RANGE



RAILROAD SEATING & TABLES



View or download other product e-brochures at the following link:

www.furnitubes.com/brochures



© Furnitubes

 **Furnitubes**[®]

3rd Floor, Meridian House, Royal Hill, Greenwich

LONDON SE10 8RD

T: +44 (0)20 8378 3200

F: +44 (0)20 8378 3250

sales@furnitubes.com

www.furnitubes.com