

CALEDONIAN LITTER BIN

Dual compartment litter and recycling

The Caledonian dual compartment construction, allowing general litter and recycling to be collected in a single unit. The Caledonian has a side-opening design with a slam lock mechanism, which is operated with a single key. The simple folded panel construction suits most sites, and is offered in either steel with a powder coated finish to the colour of your choice or in stainless steel in a satin or bright polished finish. The bin contains two separate liners with 85 and 65 litre capacity for general waste and recycling content respectively. Caledonian recycling bins are supplied with the 'Recycling' and 'Tidyman' logos as standard on both sides of the bin. A cigarette stubber and ash pocket are optional additions.

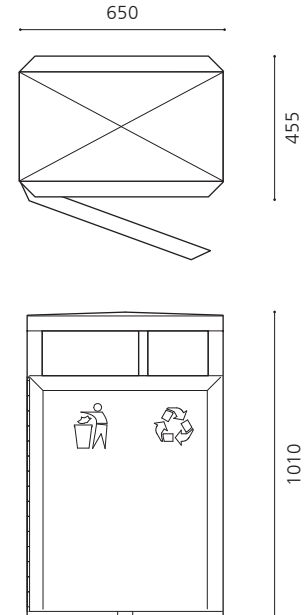

CALEDONIAN

Dual compartment litter bin with cut-out tidyman & recycling logo graphics, complete with twin zintec steel liners, capacity 85 & 65 litres

CAL 650

Zintec steel litter bin in polyester powder coated finish

CAL 650 S

Stainless steel G304 litter bin in satin polished finish

OPTIONS:

- Single compartment with 150 litre liner
- Cigarette stubber
- Without graphics

Installation:

The bin base has 4 no. triangular cut-outs to take M12 ground anchors (not supplied)