

LETTERFORM® RANGE CYCLE STANDS

Spell it out!

With the ever-growing popularity of cycling, our town centres, workplaces and leisure facilities need to provide evermore provision for securely parking our bikes. Standard hoop-style cycle stands and racks are perfectly functional but when used en masse can present something of an eyesore, particularly when only part-used. The Letterform range of stands brings something very different to cycle parking provision - letters can be arranged to spell out the cycle parking function, the name of the site or company, or even a message. As standard, each letter is manufactured in heavy duty steel bar with a polyamide coating to provide a robust, secure and attractive product for many years.



As well as 26 distinctive alphabet characters we also offer a complementary simple square form 'blank' for use when more cycling parking is required than can be provided by suitable words made up by Letterforms.



As well as product and landscape design enthusiasts, our designers have a keen interest in typography and have developed these Letterforms from geometric sans serif fonts originating from Germany in the 1920s. The simple bold designs of these silhouettes lend themselves to three dimensional outlines in steel, with a few of our own subtle changes to improve their effectiveness as cycle stands, their typographic legibility and for ease of manufacture.



LETTERFORM

STANDARD SPECIFICATION:
Mild steel construction, black polyamide coated
For in-ground fixing, c/w 300mm b/g root

OPTIONS:

- Base plated for bolt-down fixing
- Polyamide coated to any RAL colour (subject to minimum quantity order)
- Stainless steel in grades 304 / 316, bright or satin polished



LETTERFORM® RANGE CYCLE STANDS

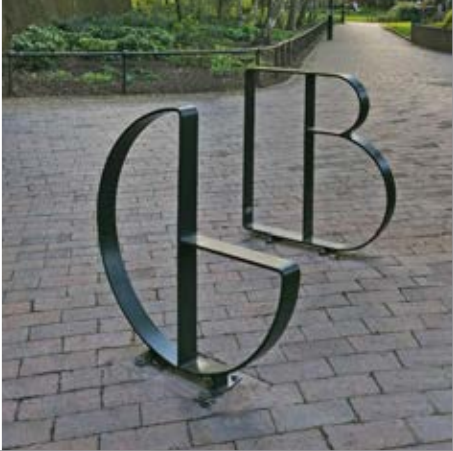

© Furnitubes Ref: 5729-04-17

LETTERFORM CYCLE STANDS - Registered Designs of Furnitubes International Ltd
LETTERFORM® - Registered Trade Mark of Furnitubes International Ltd

LETTERFORM® RANGE CYCLE STANDS

Refer to introduction page for standard specification & options on fixings, materials & finishes for all letter forms.

LETTERFORM CYCLE STANDS - Registered Designs of Furnitubes International Ltd

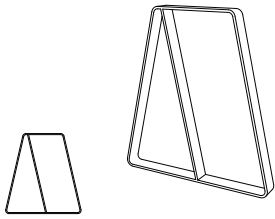

'A' LETTERFORM

LET 650 A PM

705mm x 750mm a/g x 300mm b/g

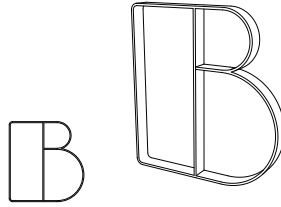

'B' LETTERFORM

LET 650 B PM

700mm x 750mm a/g x 300mm b/g

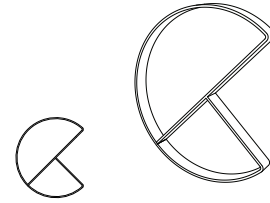

'C' LETTERFORM

LET 650 C PM

630mm x 750mm a/g x 300mm b/g

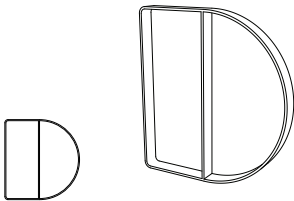

'D' LETTERFORM

LET 650 D PM

700mm x 750mm a/g x 300mm b/g

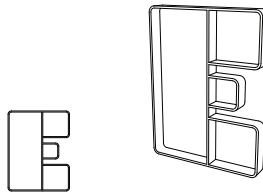

'E' LETTERFORM

LET 650 E PM

575mm x 750mm a/g x 300mm b/g

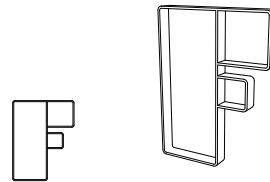

'F' LETTERFORM

LET 650 F PM

575mm x 750mm a/g x 300mm b/g

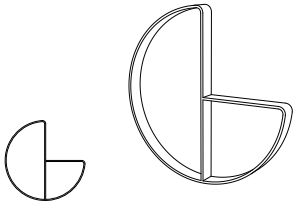

'G' LETTERFORM

LET 650 G PM

750mm x 750mm a/g x 300mm b/g

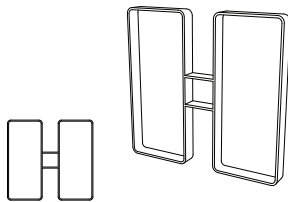

'H' LETTERFORM

LET 650 H PM

800mm x 750mm a/g x 300mm b/g

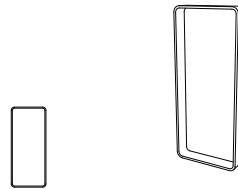

'I' LETTERFORM

LET 650 I PM

375mm x 750mm a/g x 300mm b/g

© Furnitubes Ref: S-692-03-17

LETTERFORM CYCLE STANDS - Registered Designs of Furnitubes International Ltd
LETTERFORM® - Registered Trade Mark of Furnitubes International Ltd



LETTERFORM® RANGE CYCLE STANDS

Refer to introduction page for standard specification & options on fixings, materials & finishes for all letter forms.

LETTERFORM CYCLE STANDS - Registered Designs of Furnitubes International Ltd

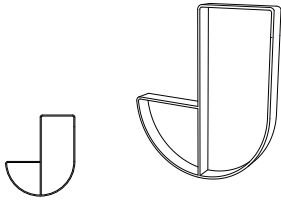

'J' LETTERFORM

LET 650 J PM

650mm x 750mm a/g x 300mm b/g

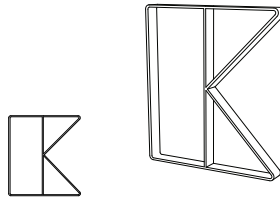

'K' LETTERFORM

LET 650 K PM

675mm x 750mm a/g x 300mm b/g

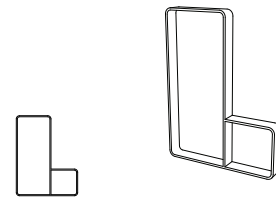

'L' LETTERFORM

LET 650 L PM

575mm x 750mm a/g x 300mm b/g

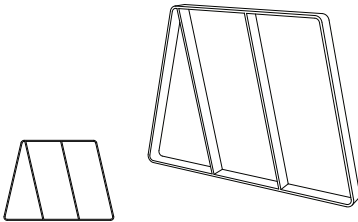

'M' LETTERFORM

LET 650 M PM

1030mm x 750mm a/g x 300mm b/g

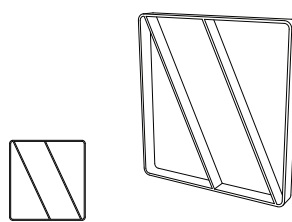

'N' LETTERFORM

LET 650 N PM

710mm x 750mm a/g x 300mm b/g

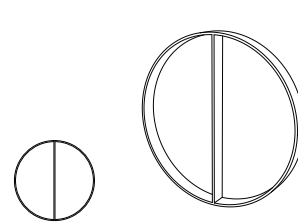

'O' LETTERFORM

LET 650 O PM

750mm x 750mm a/g x 300mm b/g

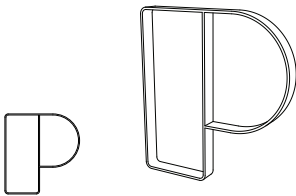

'P' LETTERFORM

LET 650 P PM

700mm x 750mm a/g x 300mm b/g

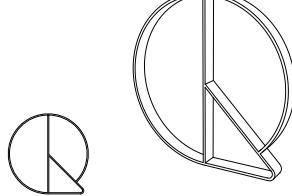

'Q' LETTERFORM

LET 650 Q PM

750mm x 750mm a/g x 300mm b/g

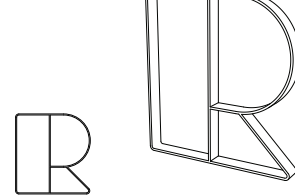

'R' LETTERFORM

LET 650 R PM

700mm x 750mm a/g x 300mm b/g

© Furnitubes Ref: S-693-03-17

LETTERFORM CYCLE STANDS - Registered Designs of Furnitubes International Ltd
LETTERFORM® - Registered Trade Mark of Furnitubes International Ltd



LETTERFORM® RANGE CYCLE STANDS

Refer to introduction page for standard specification & options on fixings, materials & finishes for all letter forms.

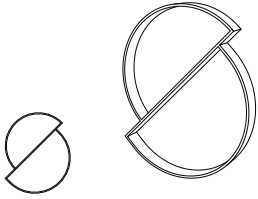

'S' LETTERFORM

LET 650 S PM

610mm x 750mm a/g x 300mm b/g

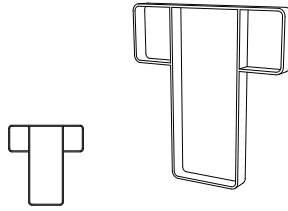

'T' LETTERFORM

LET 650 T PM

700mm x 750mm a/g x 300mm b/g

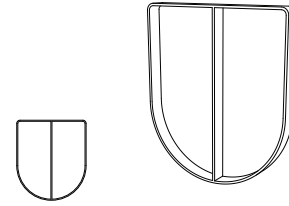

'U' LETTERFORM

LET 650 U PM

650mm x 750mm a/g x 300mm b/g

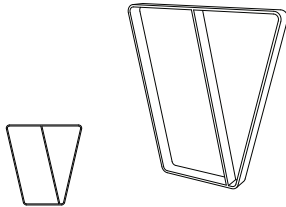

'V' LETTERFORM

LET 650 V PM

705mm x 750mm a/g x 300mm b/g

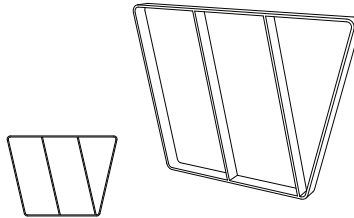

'W' LETTERFORM

LET 650 W PM

1030mm x 750mm a/g x 300mm b/g

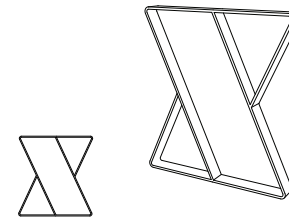

'X' LETTERFORM

LET 650 X PM

685mm x 750mm a/g x 300mm b/g

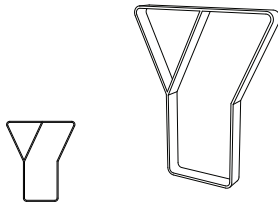

'Y' LETTERFORM

LET 650 Y PM

635mm x 750mm a/g x 300mm b/g

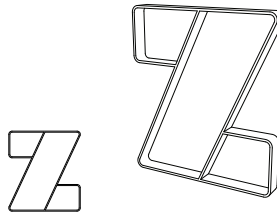

'Z' LETTERFORM

LET 650 Z PM

670mm x 750mm a/g x 300mm b/g

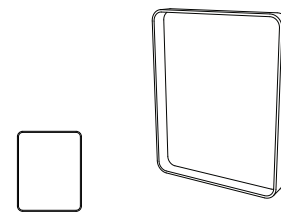

BLANK LETTERFORM

LET 650 OO PM

600mm x 750mm a/g x 300mm b/g



LETTERFORM® RANGE CYCLE STANDS

All Letterforms

In an ideal situation, the word to be spelled would equate to the number of cycle parking places required. An all-Letterform arrangement makes a striking feature, particularly at prominent positions on a site, such as along a front boundary or facade, serving not just the practical role of providing cycle parking, but also reinforcing the identity of the establishment.

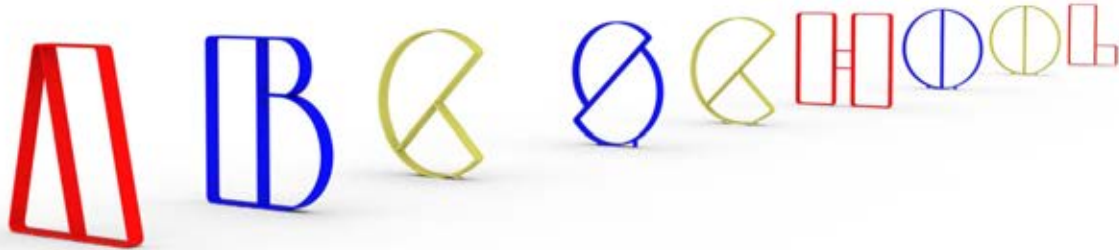

Letterforms & blanks

If the word(s) to be spelled provide fewer cycle parking places than required, additional provision can be added by using the complementary 'blank' version of the Letterform, which generally speaking will also be a more cost effective solution as the blanks are simpler than most Letterforms in terms of manufacture.



LETTERFORM® RANGE CYCLE STANDS

In-ground fixed stands

ADVANTAGES:

- Neat appearance
- More secure as generally a more solid fixing with no bolts that can be tampered with

DISADVANTAGES:

- More expensive as requires ground excavations with a foundation pad to be laid, or core drilling of holes to fix the root sections into.
- Removal / replacement requires ground excavation

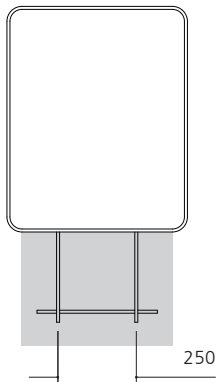
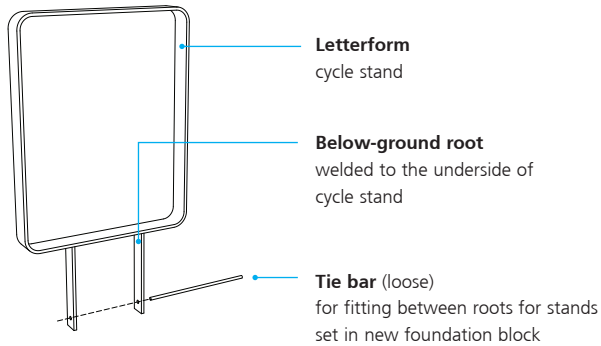

New foundation block

Insert tie bar through holes in both root sections to provide key into concrete.

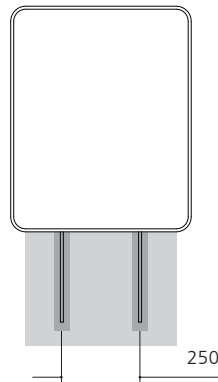

Existing foundation block

Drill / core holes to align with root sections and set in suitable mortar / resin.

Bolt-down stands

ADVANTAGES:

- Generally cheaper to install as 4 holes and 4 bolts only
- Ease of removal / replacement - no ground excavation

DISADVANTAGES:

- Less attractive detail
- Less secure if standard-type bolts are used, which can be unscrewed (we suggest using tamper-proof fixings such as shear nuts)

Note: base plate version cycle stands use the same basic letterform structure as in-ground stands, with the base plates being add-on parts that increase the overall height of the stands by 20mm, from 750mm to 770mm.

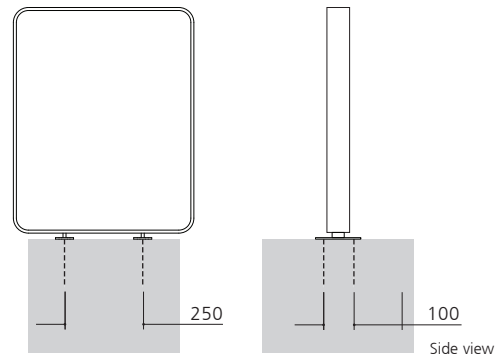
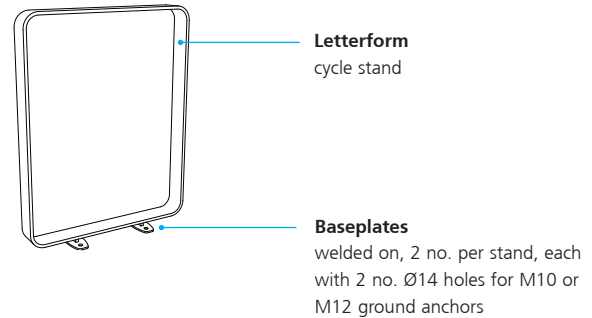

Existing or new foundation block

Mark out and drill holes to suit ground anchors (not supplied).

LETTERFORM® RANGE CYCLE STANDS



© Furnitubes Ref: 5730-06-19

LETTERFORM CYCLE STANDS - Registered Designs of Furnitubes International Ltd
LETTERFORM® - Registered Trade Mark of Furnitubes International Ltd

