

A photograph of a modern outdoor space featuring curved, light-colored steel retaining walls filled with various green plants and shrubs. The walls are topped with wooden slats. In the background, there is a paved walkway, a glass-walled building with a 'John' sign, and a stroller. The overall scene is bright and contemporary.

AKRI[®] steel retaining walls.

Akri.



Now with standard radii's and additional seating options

Sustainable, lightweight and made from recycled steel; AKRI is the perfect solution for large planting beds that may be part of a wider scheme. Our newly enhanced AKRI is crafted from both straight and curved panels with the option of various finishes and accessories that can also be retrofitted as well as seating options across our modular range. Here you're in the driver's seat, with creative license.

With expert feedback and our vigorous in-house testing, we've refined the AKRI product even further with standardised radii, angles and lengths – so you can specify with confidence knowing that the needs of your project will be met; and if not we'll commit to helping you get there.

Additional seating options for AKRI have also been made possible so you can combine the beautiful high-quality textures of Iroko wood with AKRI's retaining walls and planter system to produce unique and environmentally friendly configurations that will enhance the outdoors.



Why AKRI

Our modular solutions are made to adapt, but the AKRI steel retaining walls have been cleverly designed to meet the requirements of any project be it a large scheme or an intimate rooftop allotment – this is not your average retaining wall.

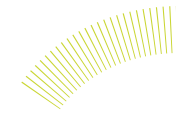

- Modular – simple and easy to specify and install
- Tested and approved by Arup
- Sustainable and cost effective retaining wall solution
- More creative freedom with shapes, curves and finishes
- Lightweight solution, ideal for podiums and roof gardens
- Made to order
- Retrofitting options available
- Now with additional integrated seating
- Delivered pre-assembled with all brackets, fixings and IKEA-like assembly instructions



AKRI 300 VS AKRI 600

available curved and straight

AKRI is available in two thicknesses. 3mm which requires a top return folded over for extra support, and 6mm which comes with a softened bevelled edge instead – both are available with straight and curved panels.

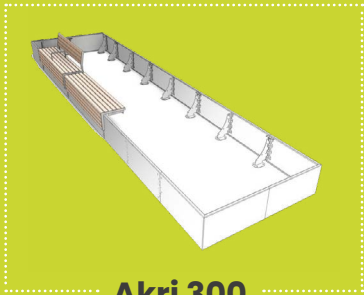

- Available in 2 ranges: AKRI300 & AKRI600
- Straight and curved panels
- Panel length: around 2m long
- Panel heights: from 300mm to 1100mm
- Bespoke panel heights can be made to allow for levels and clashes
- Optional add-on seats and benches

Finishes

Choice of steel finish:

- Powder Coated Mild Steel
- CorTen
- Stainless Steel

Choice of timber finish:

- Iroko, untreated for natural weathering
- Iroko with UV protective finish



Powder Coated Mild Steel



CorTen



Stainless Steel



Steel Finish



Retrofit with ease

Our modular range is easy to specify and it's even easier to retrofit. Each product has been designed to facilitate easy additional upgrades to be made in the future; whether you're just adding additional seating or replacing a whole unit.

We know replacing street furniture can be expensive so we make sure that fixing points are easily accessible and that slats and brackets can also be changed easily when damaged. It's cheaper in the long run, better for the environment and again you're in the driver's seat. You have more creative freedom with AKRI, choose from our add-ons (which are available in various colours and finishes) for a unique solution, especially effective on rooftops and podiums.

- Planters
- Add-on seating (benches with or without brackets)
- Pedestals and trays

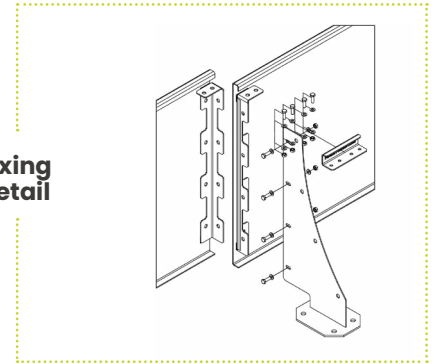



Greening the grey

Raised planter systems can be used to define spaces and pedestrian movement; but at Furnitubes we're all about greening the grey and shaping outdoor spaces that people can enjoy safely. As urbanisation and higher density urban developments put more pressure on the environment, we know that reintroducing plants and greenery will bring many benefits to communities. See how we've transformed spaces with AKRI so far.

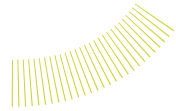

Some of our recent projects where you can see AKRI in its full glory



AKRI 300 with integrated seating at a residential project in Bexleyheath, Kent

Why Furnitubes.



- **Made in the UK** – our factory is based in Kent, so our goods don't have very far to go
- **Easy to maintain + low labour costs** – we make sure that fixing points are easily accessible so slats and brackets can be changed easily when damaged
- **Modular solutions** – our ranges are modular and customisable, seating and planters can be easily combined, be creative without blowing the budget
- **Our approach** – we take a considered approach to design, it's not just about the end product. We take everything in the process into consideration, we are collaborative and we are committed to producing products that improve our environment & keep people safe.



Get in touch!



www.furnitubes.com • specify@furnitubes.com

 [Furnitubes](https://www.instagram.com/furnitubes)  [@FurnitubesUK](https://twitter.com/FurnitubesUK)  [Furnitubes International UK](https://www.linkedin.com/company/furnitubes-international-uk)

Our Process

- **Get in touch** – it's as simple as that, give us a call or drop us an email, we're happy to help whatever the medium!
- **Collaborate** – depending on your needs you might not actually need us at this stage, that's the beauty of our modular range – it's designed with you in mind, so you can specify with ease. But we are here for you if you do – our design team are always on hand to discuss the nitty gritty of your project.
- **Specification** – This is where our team of experts take the wheel and help you with sketches, cads, you name it! To help you specify our products as easily as possible.
- **Production + delivery** – all of our products are designed and manufactured in the UK allowing us to give you shorter lead times; and with a dedicated project manager keeping you in the loop, you can trust everything is in hand.



Furnitubes



@FurnitubesUK



Furnitubes International UK

