

ALTHON 450MM DUCTILE IRON FLAP VALVE

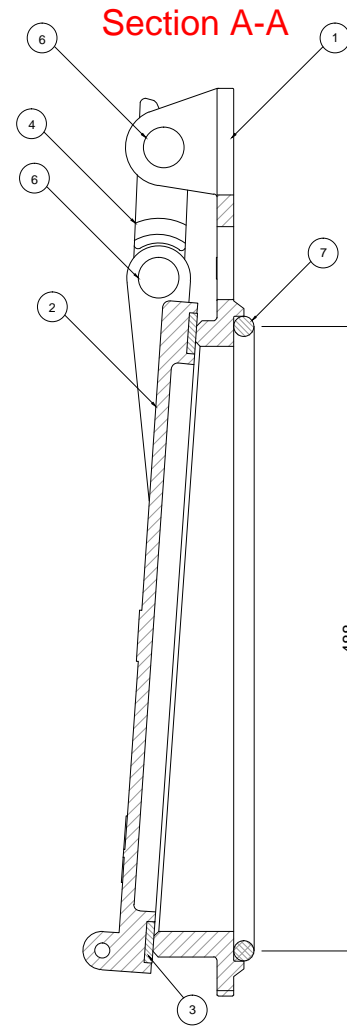
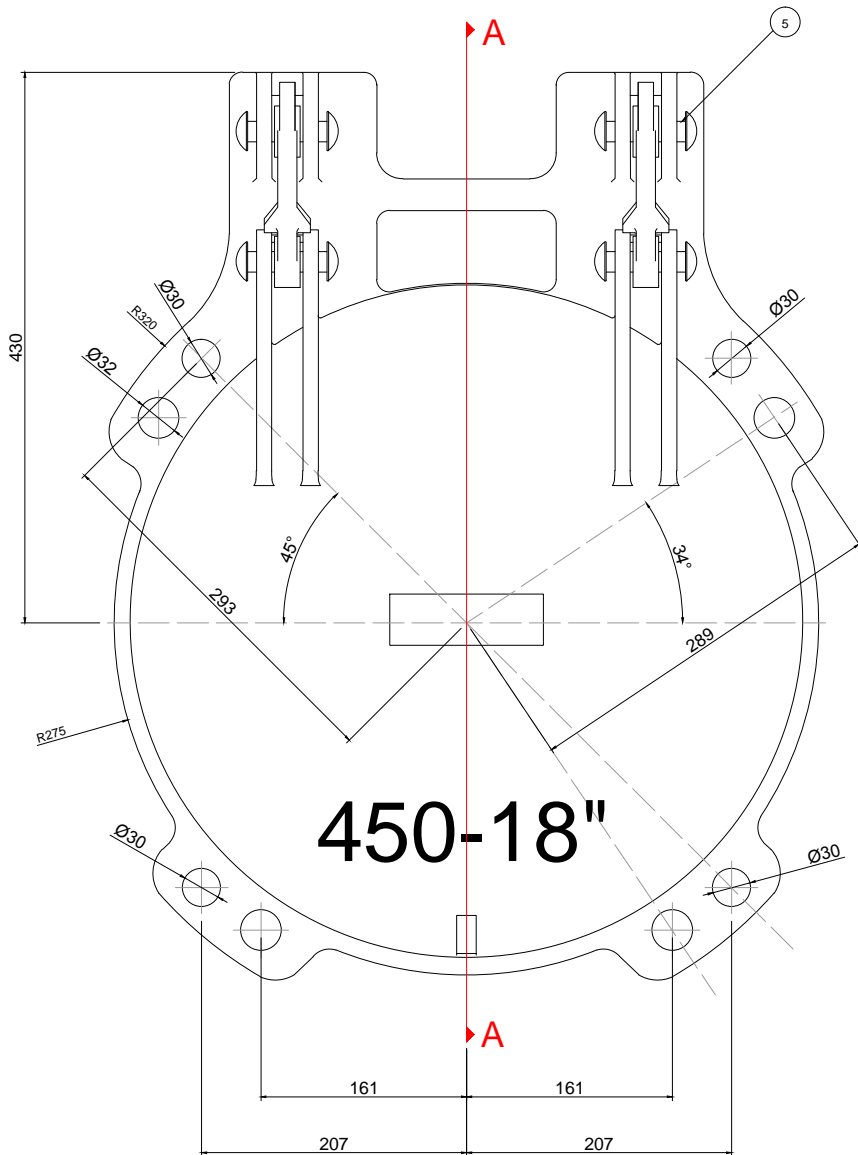

Althon 450mm Resilient Flap Valve Mounting Specification Information

The O ring item 7 is for mounting the flap valve onto a pipe flange or high quality flat surface and is supplied as part of the fixing kit which needs to be ordered separately.
For standard wall mounting the flap valve should be grouted in the normal way.

450MM RESILIENT FLAP VALVE				
ITEM	QTY	PART NUMBER	DESCRIPTION	MATERIAL
1	1	450FRAMERESASME	450mm Frame	Ductile iron casting
2	1	450RESDOOR	450mm Door	Ductile iron casting
3	1	450RESFACE	450mm Resilient Face	Resilient epoxy material
4	2	LINKR1	450mm Hinge Link	Ductile iron casting
5	4	16MMPIN	450mm Hinge Pin	Stainless steel - grade 316
6	8	M16STAR	16mm Star Washer	Stainless steel - grade 316
7	1	504X16ORING	504x16 O Ring	Neoprene foam

ADDRESS : ALTHON LIMITED
VULCAN ROAD SOUTH
NORWICH
NR6 6AF

TEL: 01603 488700
FAX: 01603 488598
EMAIL: sales@althon.co.uk
WEBSITE: www.althon.co.uk

DRAWING TITLE:

450MM DUCTILE IRON FLAP VALVE

SCALE: NTS PAPER: A1 DATE: 08 - 09 - 15

DRAWING No: 450FV