

NOTES:

- The valve plate and the back plate are produced using HDPE/SS
- The hinge pin and ballast weight are produced in SS316 as standard
- The ballast weight can be easily adjusted if required
- The sealing arrangement consists of an EPDM lips seal in the back plate
- The valve plate is also installed on an angle in relation to the back plate to ensure a good seal

Material: HDPE, SS316, EPDM
 Opening: $\varnothing 1200\text{mm}$
 Max load from bottom invert level (B.I.L):
 2.2MWC long period (=50 years)
 5MWC short period (=72hours)
 All dimensions in mm

REV NO:	DATE:	DESCRIPTION:
---------	-------	--------------



ADDRESS: ALTHON LIMITED
 VULCAN ROAD SOUTH
 NORWICH
 NR6 6AF

TEL: 01603 488700
 FAX: 01603 488598
 EMAIL: sales@althon.co.uk
 WEBSITE: www.althon.co.uk

PROPRIETARY & CONFIDENTIAL

The information contained in this drawing is the sole property of Althon Limited. Any reproduction in part or as a whole without the written permission of Althon Limited is strictly prohibited.

DRAWING TITLE:

1200mm
 Square Flap Valve

CLIENT:

SCALE:	PAPER:	DATE:
NTS	A4	19 - 03 - 18

SHEET NO:	WEIGHT:
01 OF 01	80kg

PRODUCT NAME:

ATK 1200

DRAWING No:

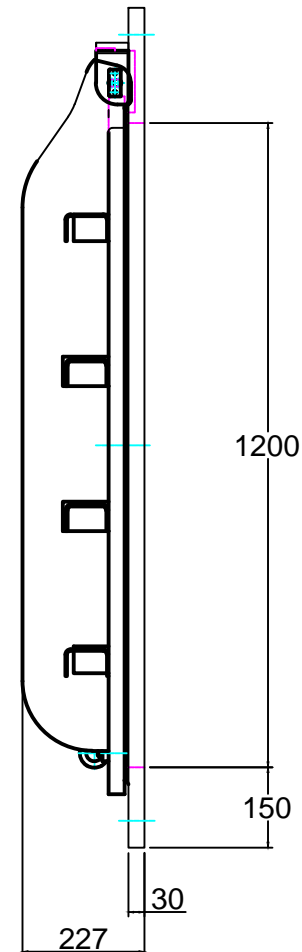
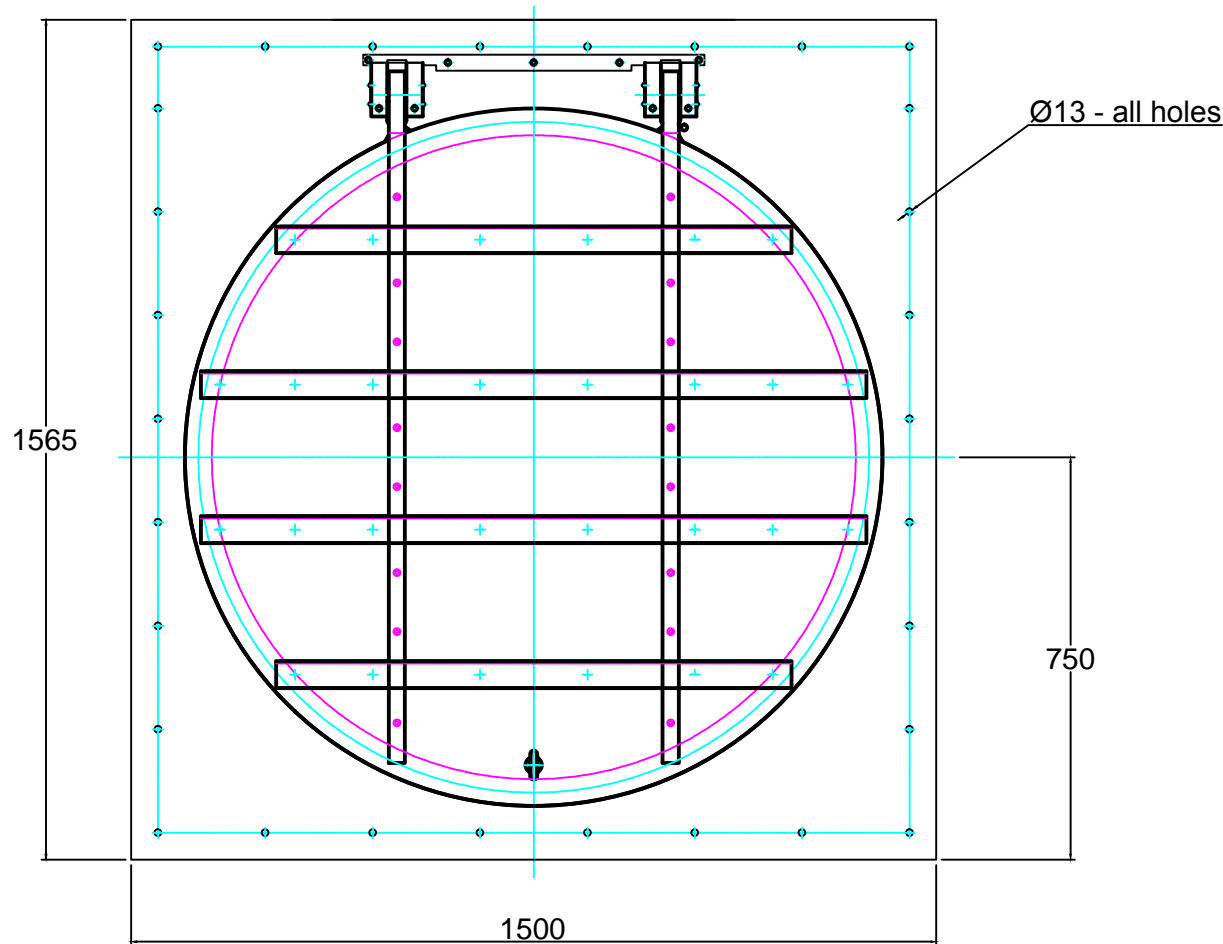
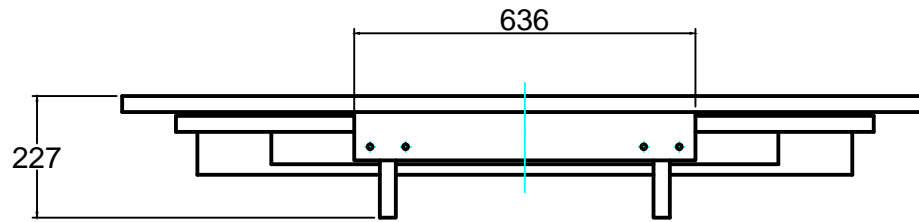

DO NOT SCALE DRAWING