

# AH12C Headwall Range



AH12CA LH

AH12CB LH

Up to 900mm Pipework  
1300mm - 1550mm Backwall Height

The AH12C Headwall is a two part PCC Headwall that allows water to discharge at 45 Deg. angle, the Environment Agency's preferred method when discharging into a watercourse. The AH12C Headwall also complies with 'Sewers for Adoption' guidelines.



AH12CA RH

AH12CB RH

The AH12C is available with two back wall height options, two toe thickness options both available in three depths. The AH12C A option can accommodate Twin Wall or PCC pipes up to and including 750mm ID and the Ah12C B option can accommodate Twin Wall or PCC pipe up to and including 900mm ID.

Headwall	Max Pipe Opening Twin Wall	Max Pipe Opening Concrete	A	B	Approx Weight kg	Weight with 300mm thick toe kg			Weight with 500mm thick toe kg		
						400mm	650mm	950mm	500mm	750mm	1000mm
AH12CA LH	750	750	1300	100	3025	3975	4575	5285	4405	5095	5785
AH12CA RH	750	750	1300	100	3025	3975	4575	5285	4405	5095	5785
AH12CB LH	900	900	1550	350	3490	4440	5040	5750	4870	5560	6250
AH12CB RH	900	900	1550	350	3490	4440	5040	5750	4870	5560	6250

\*All figures based on a invert level of 100mm. If invert level of less or greater than 100mm is required max pipe size might vary.

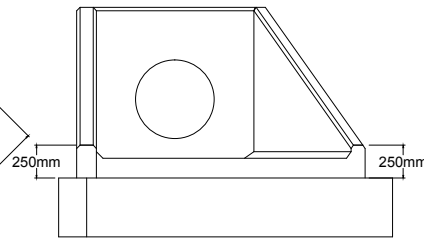
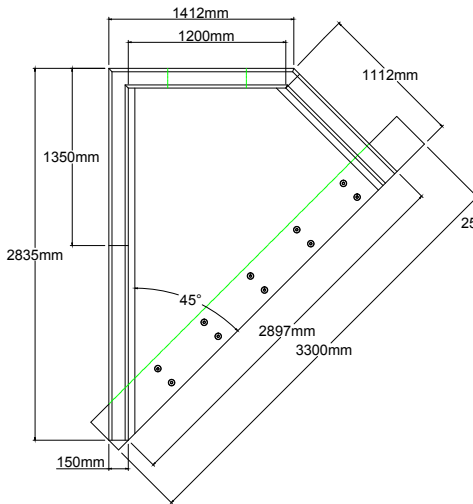

AH12C Left Hand Angled Headwall

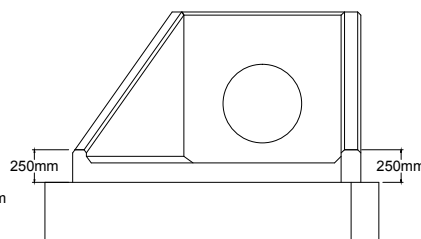
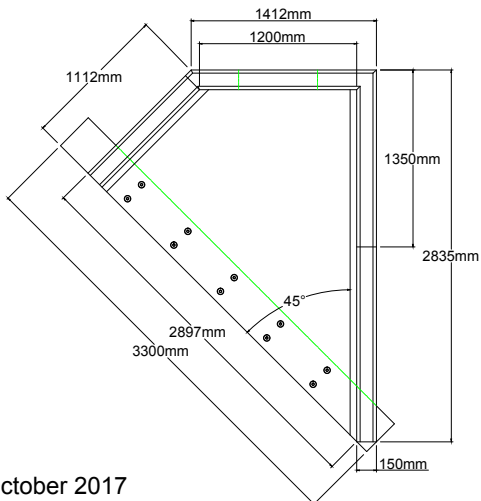
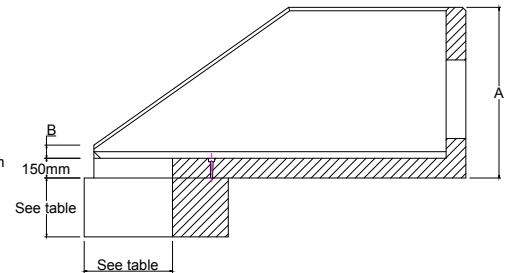

AH12C Right Hand Angled Headwall

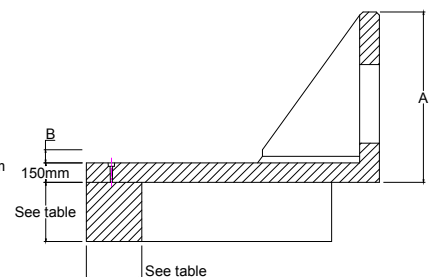

# Installation Guidelines

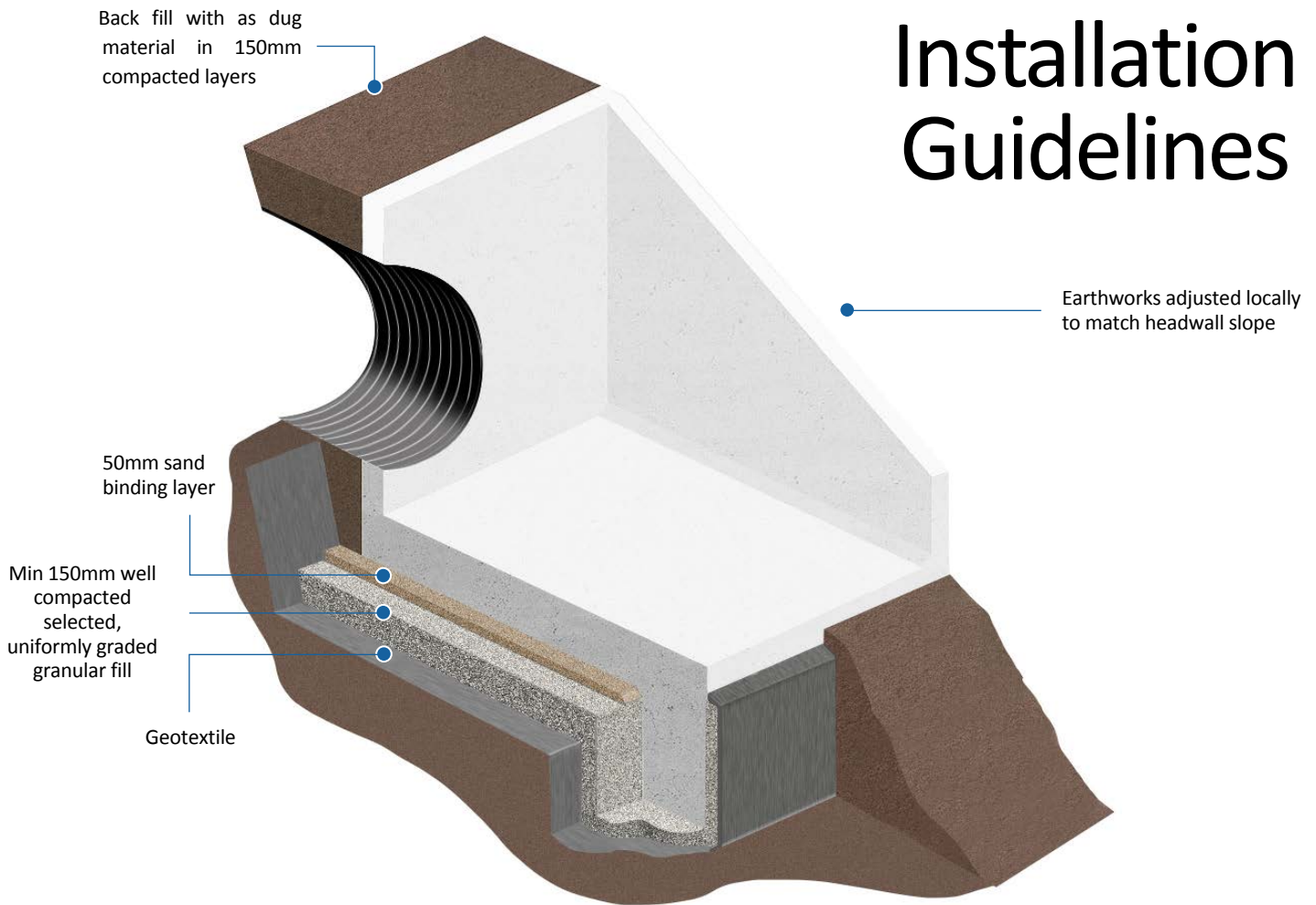

- 1 Ensure that first or last spigot/butt or socket/butt pipe that is to be fitted to the Headwall is in position and free from backfill.
- 2 Dig out the bank of the watercourse to take the size of the headwall making sure that the Headwall will not protrude into the path of the water flow. The angle of the excavation to the rear of the Headwall should be roughly the same as the existing bank profile.
- 3 Dig out sufficient size trench to take the toe along the front of the foundation.
- 4 Line toe foundation with Geotextile then place selected, uniformly graded granular fill in the base and compact well. Lift Toe into position and level then fill around the toe with selected, uniformly graded granular fill and compact well. Insert supplied threaded rod into the sockets cast into the top of the toe.
- 5 Line the base of the rest of excavation with Geotextile then place a minimum bed of 150mm Class 6A\* Selected Well Graded Granular Material on the base & compact well, especially around the back of the toe, then a 50mm blinding layer of sharp sand. Lift Headwall into position, over the end of the pipe & locate over threaded rod protruding from the toe and level. Place washer over threaded rod (SFA10 8 No) in recess in Headwall apron and tighten nut. Fill recess with high strength non-shrink grout.
- 6 The pipe should be flush with the front of the back wall if fitting grating or flap valve, or protruding by 50mm if not.
- 7 Shim the pipe until it is central within the opening then fill void with sand cement mortar or high strength non-shrink grout.
- 8 If flap valve or grating is supplied, this will need to be removed before the pipe is inserted and sealed into place. Then reinstall using stainless steel fixing bolts into cast in sockets. (When bolting flap valves against headwall, use a good quality sealant but do not over tighten bolts or distortion may occur resulting in the valve not seating correctly.
- 9 Backfill pipe section first then backfill all around Headwall with as dug material. Make good at front of toe with as dug material ensuring river bank is returned to its original profile. It may be necessary to provide protection in front of the toe, please refer to engineers' recommendation.

\*Manual of Contract Documents for Highway Works: Volume 1 (MCHW1), Specification for Highway Works, Series 600 (Nov 09)

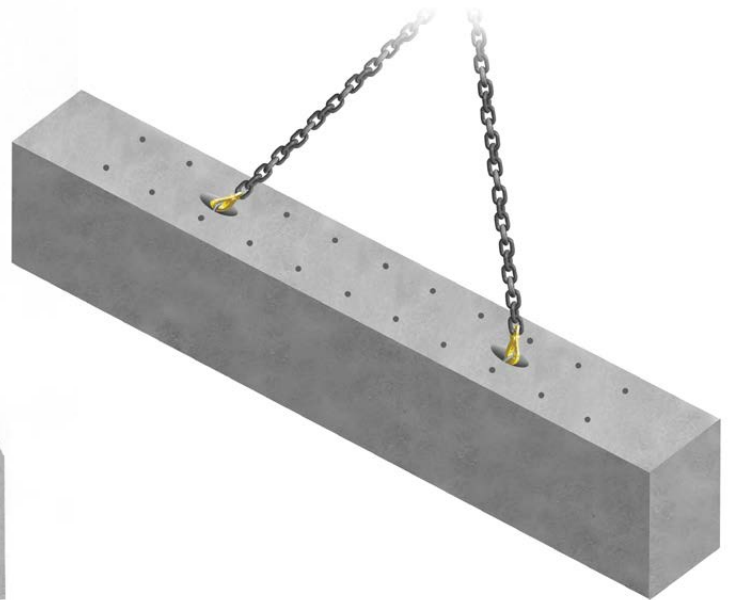

## Rapid-Lift Lifting Anchors

All Althon AH12C Headwalls and Toes are fitted with Rapid-Lift lifting anchors. The Althon Rapid-Lift system allows the AH12C Headwalls & Toes to be offloaded, transported and located in their final position without the need for any specialised lifting equipment. Standard lifting hooks and chains can be used with the three lifting points (two lifting points on Toes). The minimum chain leg length for all units is 1500mm.

## Althon Precast Concrete AH12C Headwall Safety Sheet

Althon Limited manufacture pre-cast concrete AH12C Headwalls using :-

**6 - 14mm aggregate · 0/4mm Sharp sand · Portland cement BS EN 197-1- Cem 1 52.5 · Cryso Fluid Premia 205 Varit Superplasticiser**

When units have been manufactured and cured they are in a chemically inert state. But the following information should be considered.

- It is advisable to wear toe cap safety footwear when handling any concrete products. Please refer to your company Safety Policy for specific details on manual handling.
- When cutting with masonry grinding discs or drilling with masonry drill bits it is necessary to wear eye protection and a dust mask. It is also recommended to wear ear protection during either of these two processes.
- Due to some units having sharp edges it is advisable to wear protective gloves when handling Althon products.
- When fitting or removing some of the larger accessories it is necessary to use a mechanical system to prevent risk of back injury.

## Maintenance of AH12C Headwalls

With respect to the maintenance of any exposed surfaces of concrete components, only routine (Annual) cleaning may be necessary with a Power Washer and possibly some mild detergent to any exposed surfaces to maintain appearance; however all sites are unique and environmental impact of cleaning should be taken into account. Where cleaning is required and environmental conditions prevent mild detergent, using clean water and a power washer/stiff brush should suffice. Concrete units are often expected to “weather” and some coverage will help them to blend into their environment.

If damage to the structure of any pre-cast concrete components occurs we recommend their replacement not repair. If there is minor damage to corners during their normal life by grass cutting equipment etc. then repair with an epoxy compound such as ‘Mason Mate 0868PR380 Polyester Resin’.

To dispose of any Pre-Cast concrete components the preferred method is to recycle the material by crushing and grading, but if the quantity is too small to be cost effective then disposal in conventional landfill is acceptable as all the concrete components are inert with regard to having any environmental impact.

### **Maintenance of Galvanised Grates & Handrails.**

Annual/bi-annual visual checks are basic recommendations. If gratings are in a water course subject to a higher level of debris/weed, then more regular checks may be required. Clearing of debris/weeds from the grate will ensure no disruption to the flow, or backing up of the water course. Handrails should also only require a visual inspection – annually or at the same time as the headwall & grates.