



HAWKER

LEVEL CONTROL SYSTEMS

MiniSonda

Loop Powered Ultrasonic Transmitter for non Contact Level Measurement

The MiniSonda provides accurate, reliable level measurement for liquids and slurries, it is a loop powered, ultrasonic transmitter which operates from a 20-38V D.C. voltage, thus enabling the 4-20mA signal produced to transmit over relatively long distances. If 4 control relays, digital indication and a power supply are required use flexilevel2 as a unit to add on (see data sheet No 288). If only 2 relays and a power supply are required use type 900 dual trip amp (see data sheet No 321), or the PS2 power supply with cable monitoring and lost echo (see data sheet No 292).

- Simple setting up procedure saves commissioning time.
- Low power consumption gives economical operation.
- Polypropylene casing for increased chemical resistance.
- Weatherproof to IP68 (2m for 24 hours).

Specifications

Measuring range:	0.4 to 8m
Output:	4-20mA (into 250 ohms @ 24V D.C. or 850 ohms @ 38V D.C.) (Tolerance ± 0.1 mA loop, LE ± 0.2 mA)
Loop voltage:	20-38V D.C. (reverse polarity protected).
Power required	0.5 watt @ 24V
Resolution:	1mm
Accuracy:	0.25% of measuring range (electronic).
Display:	4 digits
Minimum span:	100mm
Lost echo:	User programmable 4, 20, 21mA or last valid reading.
Temperature compensation:	Built-in digital sensor.
Ultrasonic core angle:	12°
Ultrasound frequency:	50KHz $\pm 10\%$
Operating temperature:	-10°C to +60°C
Weatherproof:	IP68 (immersion in water at 2m for 24hrs)
Gland thread:	M20
Cable:	2 core screened cable or twisted pair. (1.5m fitted as standard)
Connection:	2" B.S.P.
Ultrasonic core angle:	12°
Max static operating pressure:	-0.25 to 2bar @ 20°C
Construction materials:	Casing: - polypropylene (glass filled). Transducer housing: - UPVC
Mounting Bracket:	Swing type bracket (see drawing US 0166).

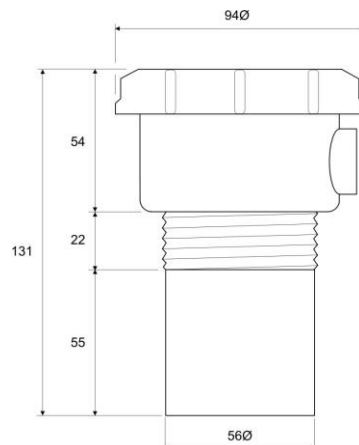

This product has been designed and complies to the relevant standards as listed in its certificate of conformity. The installer/user must ensure compliance. The crossed out bin symbol, placed on the product, reminds you of the need to dispose of the product correctly at the end of its life. Because of continuing development we reserve the right to change the specifications without notice

HAWKER ELECTRONICS LTD.

57 The Avenue,
Rubery Industrial Estate,
Birmingham B45 9AL, ENGLAND
Telephone: +44 (0)121-453-8911 Fax: +44(0)121-453-3777
email: info@hawker-electronics.co.uk www.hawker-electronics.co.uk



FM 10000



BRITISH MADE