

Hydro International plc

Shearwater House
Clevedon Hall Estate
Victoria Road
Clevedon
Somerset BS21 7RD

Tel: 01275 878371 (General enquiries)
Tel: 01275 337937 (Hydro-Brake sales/support)
Fax: 01275 874979
e-mail: enquiries@hydro-int.com
website: www.hydro-int.com



Agrément Certificate
08/4596
Product Sheet 1

HYDRO INTERNATIONAL HYDRO-BRAKE FLOW CONTROLS

S-RANGE HYDRO-BRAKE OPTIMUM FLOW CONTROLS

This Agrément Certificate Product Sheet⁽¹⁾ relates to S-Range Hydro-Brake Optimum Flow Controls⁽²⁾ a range of units to control discharge outlet flow in surface/storm water management systems.

- (1) Hereinafter known as 'Certificate'.
(2) Hydro-Brake, Hydro-Brake Optimum, Flush-Flo and Kick-Flo are trademarks of Hydro International plc.

CERTIFICATION INCLUDES:

- factors relating to compliance with Building Regulations where applicable
- factors relating to additional non-regulatory information where applicable
- independently verified technical specification
- assessment criteria and technical investigations
- design considerations
- installation guidance
- regular surveillance of production
- formal three-yearly review.

KEY FACTORS ASSESSED

Flow characteristics — the performance characteristics of the flow controls have been assessed (see section 6).

Strength — the ability of the flow controls to withstand characteristic loads has been assessed (see section 8).

Durability — under normal service conditions, the flow controls will have a life expectancy in excess of the structure in which it is installed (see section 10).



The BBA has awarded this Certificate to the company named above for the products described herein. These products have been assessed by the BBA as being fit for their intended use provided they are installed, used and maintained as set out in this Certificate.

On behalf of the British Board of Agrément

Date of Second issue: 20 July 2012

Originally certified on 18 October 2008

Handwritten signature of Brian Chamberlain in black ink.

Brian Chamberlain

Head of Approvals — Engineering

Handwritten signature of Greg Cooper in black ink.

Greg Cooper

Chief Executive

The BBA is a UKAS accredited certification body — Number 113. The schedule of the current scope of accreditation for product certification is available in pdf format via the UKAS link on the BBA website at www.bbacerts.co.uk

Readers are advised to check the validity and latest issue number of this Agrément Certificate by either referring to the BBA website or contacting the BBA direct.

British Board of Agrément
Bucknalls Lane
Garston, Watford
Herts WD25 9BA

©2012

tel: 01923 665300
fax: 01923 665301
e-mail: mail@bba.star.co.uk
website: www.bbacerts.co.uk

Regulations

In the opinion of the BBA, S-Range Hydro-Brake Optimum Flow Controls, if installed, used and maintained in accordance with the provisions of this Certificate, will meet or contribute to meeting the relevant requirements of the following Building Regulations (the presence of a UK map indicates that the subject is related to the Building Regulations in the region or regions of the UK depicted):



The Building Regulations 2010 (England and Wales)

Requirement:	H3(3)	Rainwater drainage
Comment:		The units can be used in a construction to meet this Requirement. See section 6 of this Certificate.
Requirement:	Regulation 7	Materials and workmanship
Comment:		The units are acceptable. See section 10 and the <i>Installation</i> part of this Certificate.



The Building (Scotland) Regulations 2004 (as amended)

Regulation:	8(1)(2)	Fitness and durability of materials and workmanship
Comment:		The units are acceptable. See sections 9 and 10 and the <i>Installation</i> part of this Certificate.
Regulation:	9	Building standards – construction
Standard:	3.6(a)	Surface water drainage
Comment:		The units can be used in a construction to satisfy this Standard, with reference to clauses 3.6.1 ⁽¹⁾⁽²⁾ to 3.6.5 ⁽¹⁾⁽²⁾ . See section 6 of this Certificate.
Standard:	7.1(a)(b)	Statement of sustainability
Comment:		The units can contribute to meeting the relevant requirements of Regulation 9, Standards 1 to 6 and therefore will contribute to a construction meeting a bronze level of sustainability as defined in this Standard.
Regulation:	12	Building standards – conversions
Comment:		All comments given for these systems under Regulation 9, also apply to this Regulation, with reference to clause 0.12.1 ⁽¹⁾⁽²⁾ and Schedule 6 ⁽¹⁾⁽²⁾ . (1) Technical Handbook (Domestic). (2) Technical Handbook (Non-Domestic).



The Building Regulations (Northern Ireland) 2000 (as amended)

Regulation:	B2	Fitness of materials and workmanship
Comment:		The units are acceptable. See section 10 and the <i>Installation</i> part of this Certificate.
Regulation:	B3(2)	Suitability of certain materials
Comment:		The units are acceptable. See section 9 of this Certificate.
Regulation:	N5	Rain-water drainage
Comment:		The units can be used in a construction to satisfy this Regulation. See section 6 of this Certificate.

Construction (Design and Management) Regulations 2007

Construction (Design and Management) Regulations (Northern Ireland) 2007

Information in this Certificate may assist the client, CDM co-ordinator, designer and contractors to address their obligations under these Regulations.

See section: 3 *Delivery and site handling* (3.3) and 11 *Installation* of this Certificate.

Additional Information

NHBC Standards 2011

In the opinion of the BBA, the use of S Range Hydro-Brake Optimum Flow Controls, in relation to this Certificate, is not subject to the requirements of these Standards.

Technical Specification

1 Description

1.1 S-Range Hydro-Brake Optimum Flow Controls are vortex flow controls manufactured from 3 mm, 5 mm or 8 mm thick grade 304 stainless steel. Alternative material thicknesses and grades are available depending on the application (outside the scope of this Certificate. For more information, the Certificate holder should be contacted).

1.2 Each unit is designed and manufactured to meet specific hydraulic requirements (see section 7). The configuration of the inlet, volute and outlet is varied to achieve the required discharge control characteristics. The units may be fitted with a fixed inlet or an adjustable inlet gate to allow for post-installation adjustment of the discharge flow rate by up to 20% (see Figure 1).

Figure 1 Fixed and adjustable inlet arrangements



1.3 The units are available in a range of sizes to give design flow rates from $0.7 \text{ l}\cdot\text{s}^{-1}$ to $250 \text{ l}\cdot\text{s}^{-1}$, suitable for use in surface/stormwater management applications. A summary of technical information is given in Table 1.

Table 1 Summary of technical information

Characteristic (units)	Typical range of values
Design flow rate ($\text{l}\cdot\text{s}^{-1}$)	0.7 to 250
Design head (m)	0.4 to 4
Maximum lateral dimension (mm)	
Lug mounted units	180 to 2000
Backplate mounted units	Dependent on discharge pipe size
Push-fit units	180 to 2000
Mass (kg) excluding packaging	
Lug mounted units	6 to 680
Backplate mounted units	Dependent on discharge pipe size
Push-fit units	6 to 680

1.4 Each unit is supplied fully assembled including:

- an S-Range Hydro-Brake Optimum Flow Control with integral bypass door on the front face of the unit, pipe location spigot and mounting face gasket or push-fit sealing rings
- wire rope to allow remote operation of the pivoting bypass door (7 mm diameter rope consisting of seven stainless steel strands each of 3 mm diameter) and stainless steel wire rope attachment brackets
- mounting anchor bolts (A4 316 stainless steel). The performance and suitability of the mounting bolts is outside the scope of this Certificate; the Certificate holder should be contacted for advice on the most appropriate fixings for individual projects.

1.5 The flow controls are available with various types of mounting arrangement (see Figure 2):

- lug mounting — lugs are provided at points around the perimeter of the flow control mounting face. This is appropriate for the majority of applications where the outlet diameter of the installation structure is approximately 0.5 times the flow control body diameter or less
- push-fit spigot — a push-fit spigot with rubber sealing rings is provided. A single lug may also be provided on the outside perimeter of the mounting face to prevent rotation of the flow control in service. Precise specification of the outlet pipe is essential for push-fit mounting, in order to ensure a watertight seal
- backplate mounting — a rectangular mounting plate is provided to allow fixing to the outlet of the installation structure where lug mounting is not appropriate. If a flat surface is not available, the mounting plate may also be provided curved to the same radius as the chamber in which it is to be fitted.

Figure 2 Standard mounting arrangements

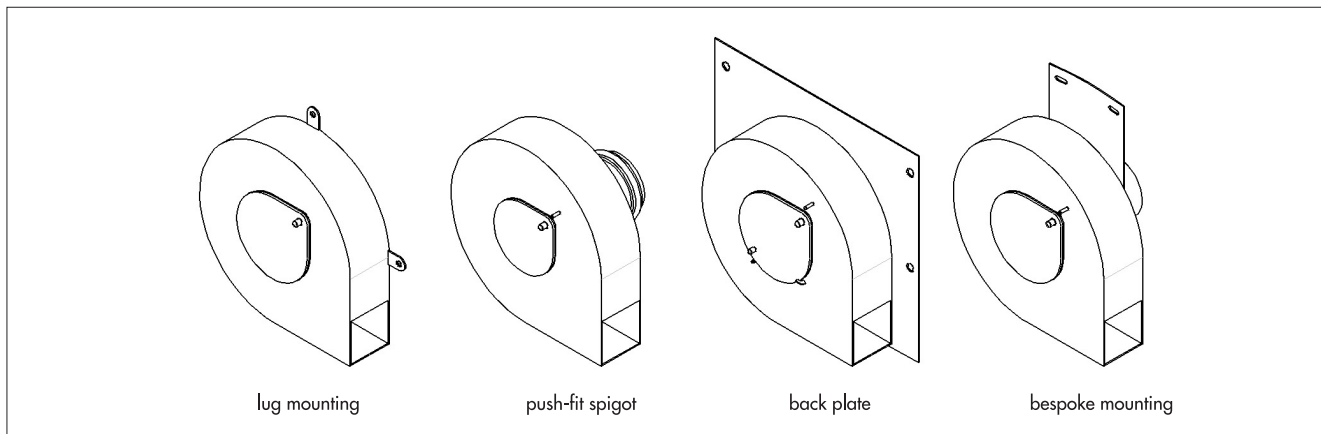

1.6 The units may be supplied for installation in purpose built or existing structural housings on site. These must have adequate strength to resist the loads imposed by the unit. The design of these structures is outside the scope of the Certificate but the performance and durability of the flow control will be unaffected, provided it is installed in accordance with the recommendations of this Certificate.

1.7 The units may also be supplied ready-fitted to purpose-built reinforced concrete or plastic manhole chambers ready for installation into the ground. The performance of these chambers is outside of the scope of this Certificate.

2 Manufacture

2.1 S-Range Hydro-Brake Optimum Flow Controls are manufactured from stainless steel sheet which is cut, rolled and welded to the required dimensions.

2.2 As part of the assessment and ongoing surveillance of product quality, the BBA has:

- agreed with the manufacturer the quality control procedures and product testing to be undertaken
- assessed and agreed the quality control operated over batches of incoming materials
- monitored the production process and verified that it is in accordance with the documented process
- evaluated the process for management of nonconformities
- checked that equipment has been properly tested and calibrated
- undertaken to carry out the above measures on a regular basis through a surveillance process, to verify that the specifications and quality control operated by the manufacturer are being maintained.

2.3 The management system of Hydro International plc has been assessed and registered as meeting the requirements of BS EN ISO 9001 : 2008 by Lloyd's Register Quality Assurance Limited (Certificate LRQ 0961366).

3 Delivery and site handling

3.1 S-Range Hydro-Brake Optimum Flow Controls are supplied in polyethylene and plywood packaging for small units and on a pallet for large units. They should be handled and stored appropriately to avoid being dropped or receiving impacts, eg from construction plant.

3.2 Each unit is stamped with the Certificate holder's unique project reference number and carries a label bearing the Certificate holder's contact information and advice on orientation. The packaging also bears details of the package weight and client details.

3.3 Care should be taken handling the units and when lowering into position for installation. Where appropriate, larger units should be lifted via the fitted lugs using mechanical lifting/lowering equipment.

Assessment and Technical Investigations

The following is a summary of the assessment and technical investigations carried out on S-Range Hydro-Brake Optimum Flow Controls.

Design Considerations

4 General

4.1 S-Range Hydro-Brake Optimum Flow Controls are intended to restrict the outlet flow from a surface/storm water management system by increasing back pressure, achieved by inducing a vortex flow pattern in the water passing through the device. In these applications, the units are often used in conjunction with storage facilities, including geocellular storage systems, concrete tanks, oversized pipes and ponds. The performance of these items is outside the scope of this Certificate. Guidance on design of sustainable drainage systems is given in Planning Policy Statement 25 *Development and Flood Risk* and CIRIA C697 *The SUDS Manual*. Typical installation details are shown in Figure 3.

Figure 3 Typical applications and design head

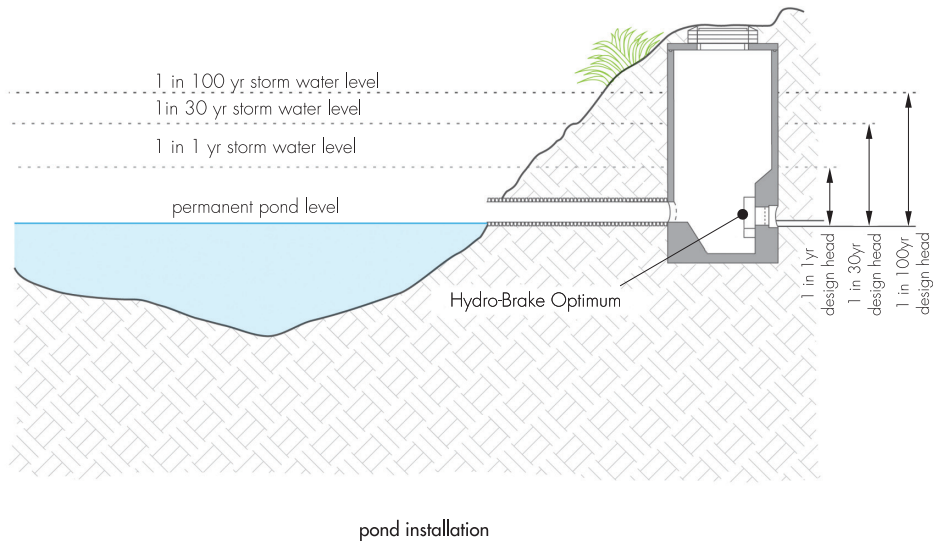
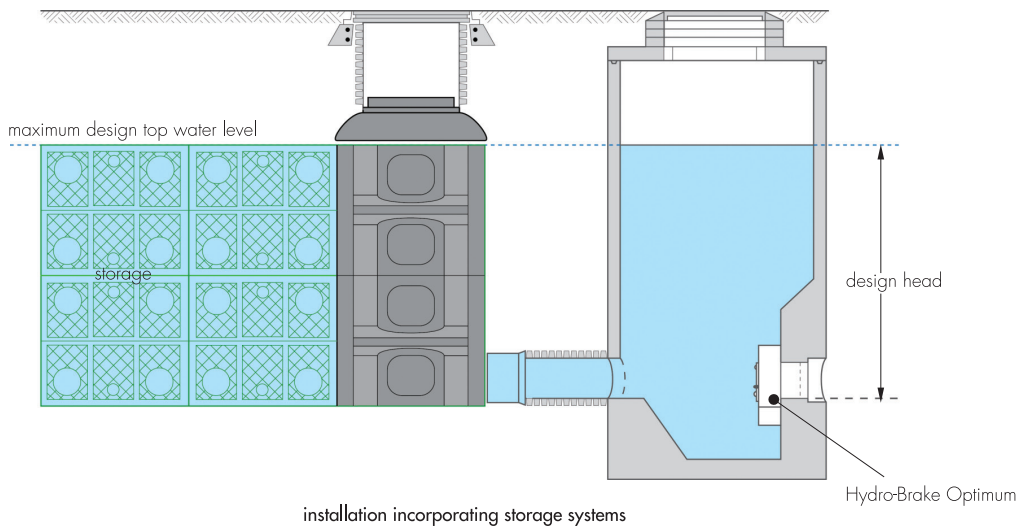
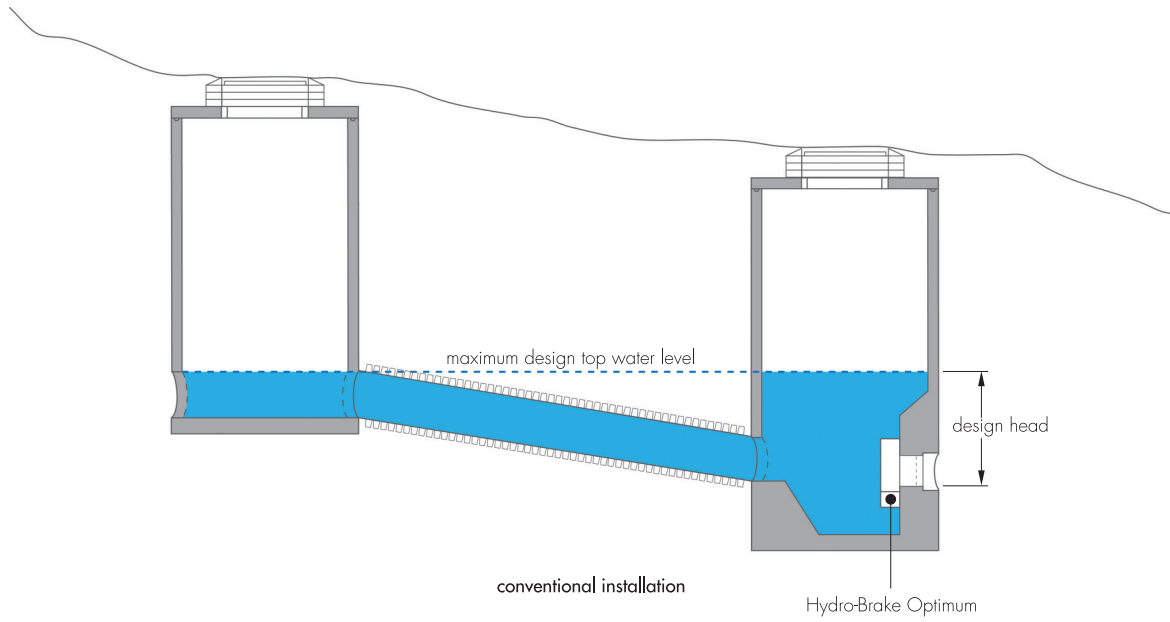

4.2 The units are self-activating; they do not have moving parts and do not require external power.

4.3 As a matter of good design practice, measures should be taken to remove silt sediment and debris from the surface water at an early stage to prevent problems further downstream.

4.4 It is recommended to maintain a minimum clear opening of 75 mm in a surface water drainage system. In some cases, it may be necessary to use a flow control with a smaller minimum opening. In which case, the installation of screens or debris removal systems upstream of the device is recommended.

5 Practicability of installation

The product is designed to be installed by a competent contractor, experienced with this type of product.

6 Flow characteristics



6.1 Due to the 'S'-shaped head-flow characteristic, the units are able to pass greater volume flow rates at lower heads, whilst still limiting the flow at the duty/design point to an acceptable level. A typical head versus flow characteristic for the units is given in Figures 4, 5 and 6.

6.2 The units have a hydraulic characteristic, comprising three distinct stages corresponding to different phases of operation (see Figures 4, 5 and 6):

- pre-initiation phase — at low heads, the flow control provides similar performance to an orifice plate with equivalent size to its outlet⁽¹⁾. Flow rate accuracy of $\pm 5\%$ of the ultimate duty/design flow is typically achievable in this region
- vortex initiation phase — as the head increases, vortex motion will start to develop inside the unit, starting to restrict the flow⁽¹⁾. Flow rate accuracy of -5% of flow to $+5\%$ of phase peak is typically achievable in this region
- post-initiation/design phase — following vortex initiation, the flow control characteristic stabilises, providing hydraulic performance equivalent to a substantially smaller orifice plate than the unit's outlet. The units can be specified to give a duty/design point in any part of this region, though in most practical cases, specification will be at flow rates above the initiation phase peak (corresponding to the Flush-Flo point). Flow rate accuracy of $\pm 5\%$ of flow is typically achievable in this region.

As the water level subsides and water in the device drains, the energy within the flow reduces and the vortex collapses. Air is drawn into the volute and the unit returns to operating in a similar manner to an orifice of the same cross sectional area. This drains the system quickly so that the upstream network is ready for the next event.

(1) Although a flow control would not usually be selected with the duty/design point in this region, this part of the characteristic will have implications to overall drainage system operation.

Figure 4 Pre-initiation phase

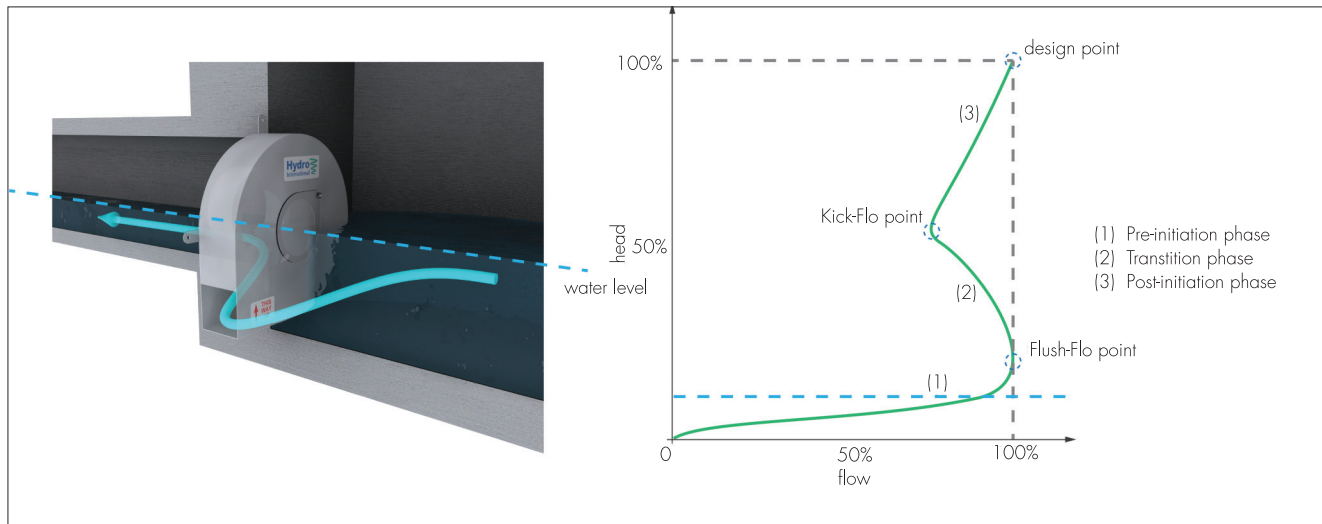

Figure 5 Vortex initiation phase

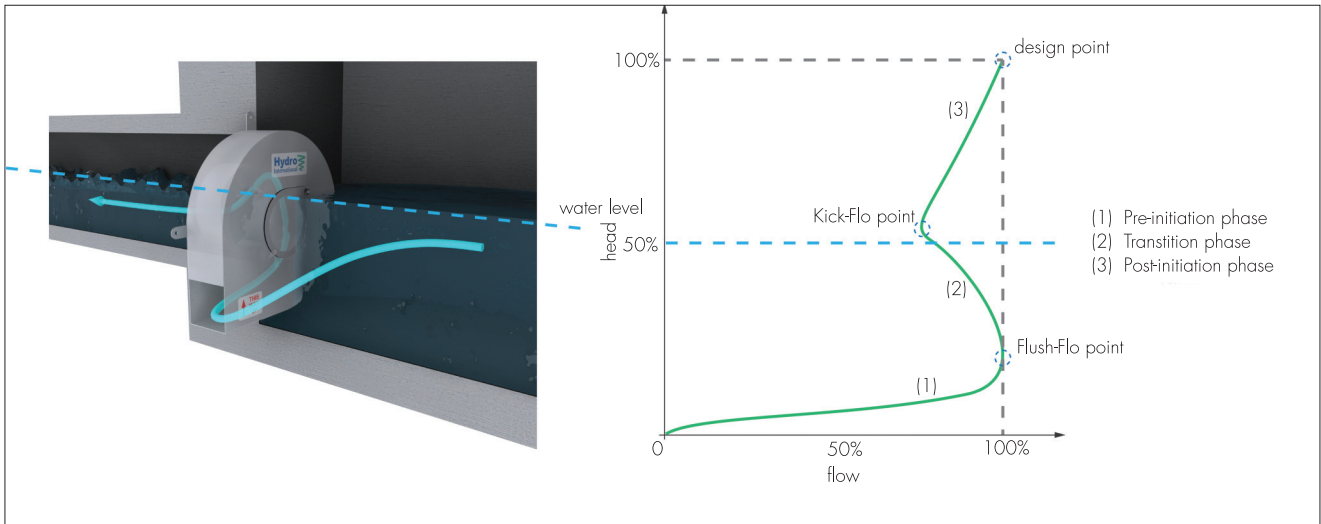
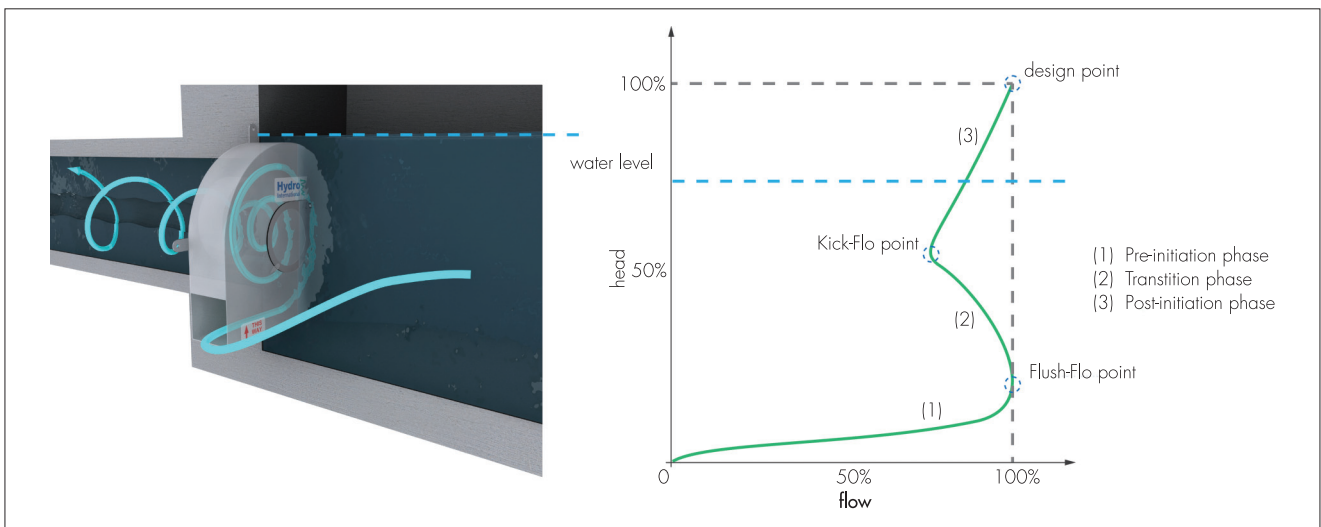

Figure 6 Post initiation phase



6.3 S-Range Hydro-Brake Optimum Flow Controls allows the inlet, volute and outlet to be individually configured to suit the application, enabling the system to be designed to provide the appropriate hydraulic performance or to suit constant discharge, multi-stage discharge or risk-based network designs (see Figure 7). Individual configuration of the inlet, volute and outlet also allows the system designer to adjust the physical dimensions of the unit in order to:

- maximise the internal clearances
- comply with minimum outlet guidelines
- retrofit to existing infrastructure.

Figure 7 Application based design

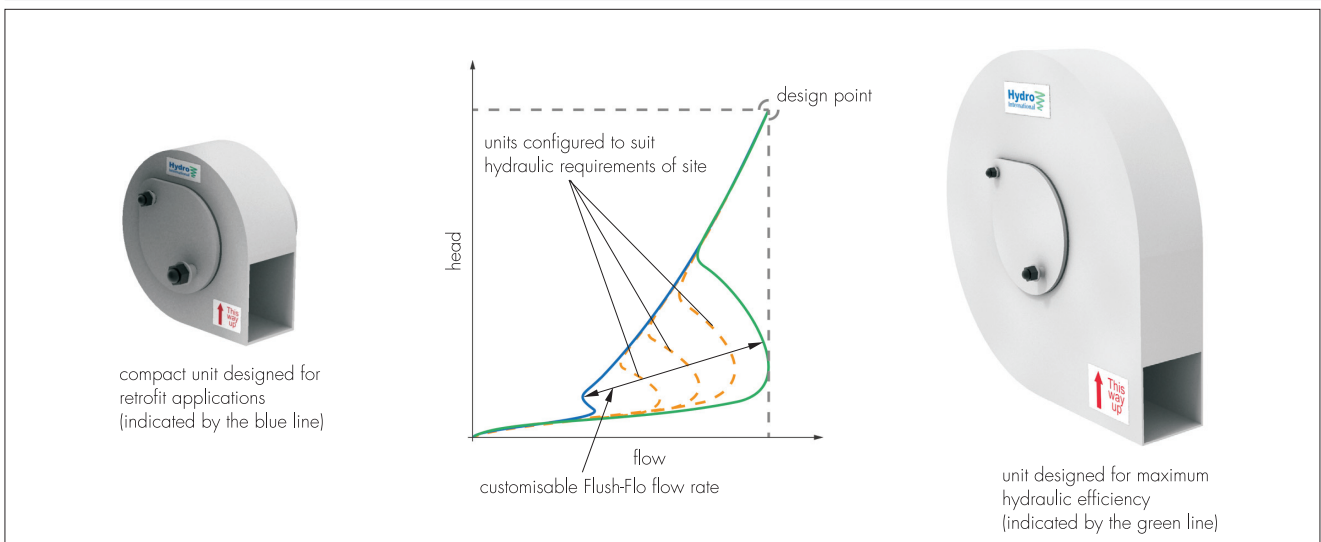

6.4 The units are specified and supplied to meet individual application requirements. The Certificate holder should be contacted directly for advice on correct selection. The following information should be provided:

- operating head — depth from the unit's outlet invert to the design water level(s) (see Figure 3)
- flow — required discharge at the given head(s)
- manhole details or control chamber proposals, including outlet size
- information on any 'special' conditions, for example if the unit is expected to be subject to downstream surcharging or possible siphoning effects.

6.5 In most cases the downstream drainage system will be designed to allow the unit a free discharge. However, this is not always possible and in certain cases it will be necessary to design the flow control to surcharge conditions. Surcharging of the flow control will affect the hydraulic performance and advice should be sought from the Certificate holder. Installations where the outlet is surcharged are outside the scope of this Certificate.

6.6 Where a drainage system has been designed and hydraulically modelled based on the use of a S-Range Hydro-Brake Optimum Flow Control, it is essential to ensure that the same flow control, or a flow control that has been confirmed to provide an equivalent hydraulic performance across the whole design head range, is used in the final installation.

7 Hydraulic design

7.1 The units are typically used to control flows across a site or to limit the rate of discharge from a site. Where used to limit the rate of discharge from a site, the allowable discharge rate to an appropriate outfall will generally be set by the Environment Agency, the Scottish Environmental Protection Agency, local Planning Authorities or the Sewer Undertaker.

7.2 The allowable discharge rate will often be calculated in respect of the greenfield equivalent run-off rate for the undeveloped site. Advice on calculating the greenfield equivalent run-off rate can be found in the *Interim Code of Practice for Sustainable Drainage Systems*. Where a site is being redeveloped, the allowable discharge rate may be determined based on the discharge rate prior to the redevelopment. The design head acting on the upstream side of the Hydro-Brake Optimum flow control will generally be determined by the maximum design top water level within the storage volume. The design head is illustrated in Figure 3.

8 Strength

8.1 The units are manufactured from stainless steel of a sufficient strength and thickness to ensure that the product remains fit for purpose throughout its design life.

8.2 Under normal operation, the units will deflect by no more than the thickness of the material used for manufacture. This ensures that the volume of the unit available for water flow is not compromised during operation and therefore the hydraulic operation of the unit is not adversely affected by deformation of the unit.

9 Maintenance



9.1 Access should be allowed for clearing debris from the chamber housing the flow control. In the event that the inlet to the unit becomes blocked, the pivoting bypass door may be operated by pulling the wire rope attached upwards to drain down the chamber and provide access for maintenance. The pivoting bypass door must be returned to the closed position following drain down of the chamber and clearance of the blockage.

9.2 Regular inspections should be carried out to ensure that debris that may obstruct the inlet to the flow control is not present in the chamber. The frequency of inspection will depend on the location of the unit but must be at least once per year.

9.3 The units can be jetted from downstream, in accordance with standard sewer jetting procedures without affecting the hydraulic performance of the system.

10 Durability



The units are made from materials that will not be adversely affected by contaminants likely to be found in surface water. In the opinion of the BBA, the units will have a design life in excess of the design life of typical structures in which they might be installed.

Installation

11 General

11.1 S-Range Hydro-Brake Optimum Flow Controls must be installed in accordance with the Certificate holder's instructions. In many cases the installation will be in a confined space and all appropriate measures must be taken to ensure the safety of operatives working in such areas.

11.2 Dimensioned drawings for each installation are provided by the Certificate holder. It is important that the flow control chamber is constructed to the drawing. Other than where a curved backplate is supplied, this should incorporate a flat mounting surface on the inside face of the chamber wall at the outlet pipe. It should also be ensured that the sump floor level is sufficiently below the invert of the outlet pipe and sufficiently disposed to accommodate the unit.

11.3 The benching/standing area should be formed as indicated on the installation drawing.

11.4 Where an adjustable inlet gate is provided, the factory set position must not be adjusted without prior consultation with the Certificate holder.

12 Procedure

12.1 The unit should be offered up to the chamber outlet wall until the spigot projects into the outlet pipe with its invert seated to the outlet pipe invert and with the unit in the correct orientation (see Figure 8).

Figure 8 Typical installation details

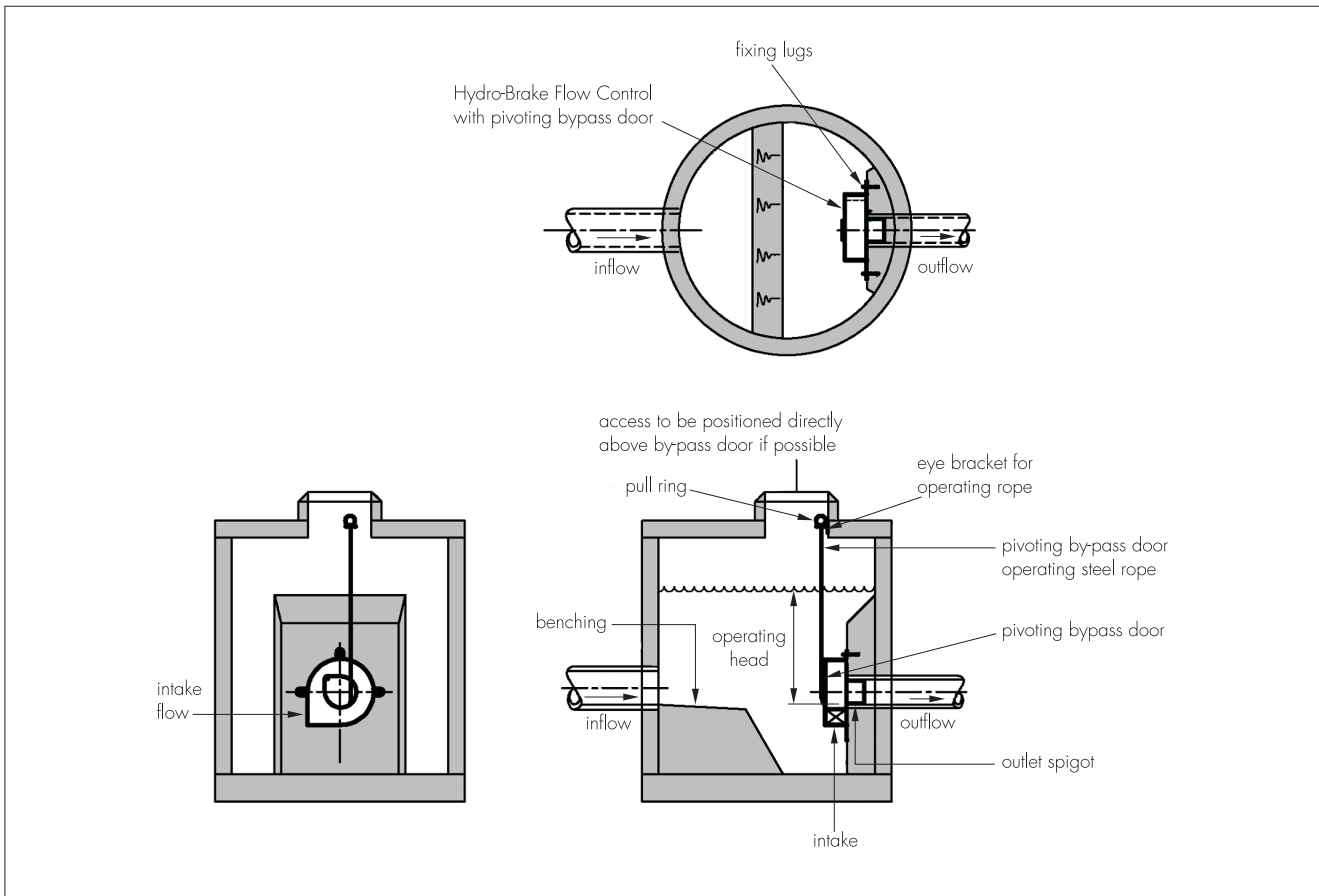

12.2 With the unit in position, the position of the required number of bolt holes is marked and drilled through the fixing lugs or plate mount (depending on specification).

12.3 Ensuring that the supplied rubber gasket is suitably positioned over the outlet spigot of the flow control, the fixings should be inserted and tightened until moderate compression of the gasket is achieved.

12.4 The supplied eye brackets on the pivoting bypass door operating rope should be fixed to the soffit of the roof slab using masonry bolts to achieve a direct vertical line of pull from over the chamber access cover to the pivoting bypass door. It should be arranged that the rope is taut when held in the upper eye bracket. Where it is not possible to attain a direct vertical line of pull, additional eye brackets can be used to account for the change of direction.

12.5 The rope stop should be positioned to ensure that, when the pivoting bypass door is open, the rope stop can be clipped to the uppermost bracket. Once positioned, the stop attachment grub screws should be tightened.

Technical Investigations

13 Tests

Tests were carried out to determine:

- dimensional accuracy of the units.
- the hydraulic performance of the units.

14 Investigations

14.1 The manufacturing process was examined, including the methods adopted for quality control, and details were obtained of the quality and composition of the materials used.

14.2 A site visit was made to assess the practicability and ease of installation.

14.3 An assessment of computational fluid dynamic (CFD) modelling used to predict the hydraulic performance of the units was made.

14.4 An assessment of the Certificate holder's predicted characteristics was made against the results of hydraulic performance tests.

14.5 An assessment of the structural adequacy of the units under loads that they are expected to resist was made.

14.6 An evaluation of existing data was made to assess durability.

Bibliography

BS EN ISO 9001 : 2008 Management systems — Quality

Conditions of Certification

15 Conditions

15.1 This Certificate:

- relates only to the product/system that is named and described on the front page
- is issued only to the company, firm, organisation or person named on the front page — no other company, firm, organisation or person may hold or claim that this Certificate has been issued to them
- is valid only within the UK
- has to be read, considered and used as a whole document — it may be misleading and will be incomplete to be selective
- is copyright of the BBA
- is subject to English Law.

15.2 Publications, documents, specifications, legislation, regulations, standards and the like referenced in this Certificate are those that were current and/or deemed relevant by the BBA at the date of issue or reissue of this Certificate.

15.3 This Certificate will remain valid for an unlimited period provided that the product/system and its manufacture and/or fabrication, including all related and relevant parts and processes thereof:

- are maintained at or above the levels which have been assessed and found to be satisfactory by the BBA
- continue to be checked as and when deemed appropriate by the BBA under arrangements that it will determine
- are reviewed by the BBA as and when it considers appropriate.

15.4 The BBA has used due skill, care and diligence in preparing this Certificate, but no warranty is provided.

15.5 In issuing this Certificate, the BBA is not responsible and is excluded from any liability to any company, firm, organisation or person, for any matters arising directly or indirectly from:

- the presence or absence of any patent, intellectual property or similar rights subsisting in the product/system or any other product/system
- the right of the Certificate holder to manufacture, supply, install, maintain or market the product/system
- actual installations of the product/system, including their nature, design, methods, performance, workmanship and maintenance
- any works and constructions in which the product/system is installed, including their nature, design, methods, performance, workmanship and maintenance
- any loss or damage, including personal injury, howsoever caused by the product/system, including its manufacture, supply, installation, use, maintenance and removal
- any claims by the manufacturer relating to CE marking.

15.6 Any information relating to the manufacture, supply, installation, use, maintenance and removal of this product/system which is contained or referred to in this Certificate is the minimum required to be met when the product/system is manufactured, supplied, installed, used, maintained and removed. It does not purport in any way to restate the requirements of the Health and Safety at Work etc. Act 1974, or of any other statutory, common law or other duty which may exist at the date of issue or reissue of this Certificate; nor is conformity with such information to be taken as satisfying the requirements of the 1974 Act or of any statutory, common law or other duty of care.