

Downstream Defender[®] Advanced Hydrodynamic Vortex Separator

The Downstream Defender[®] is an advanced hydrodynamic vortex separator for the effective and reliable removal of fine particles, oils and other floatable debris from surface water runoff.

Its innovative design delivers high efficiency across a wide range of flows in a much smaller footprint than conventional or other swirl-type devices and it is the perfect choice for any catchment likely to convey high quantities of contamination.

1. Access for removal of floatables and sediments.
2. Inlet pipe.
3. Inlet chute.
4. Centre shaft.
5. Dip plate.
6. Centre cone.
7. Benching skirt.
8. Floatables and oil storage.
9. Isolated sediment storage zone.
10. Outlet pipe.

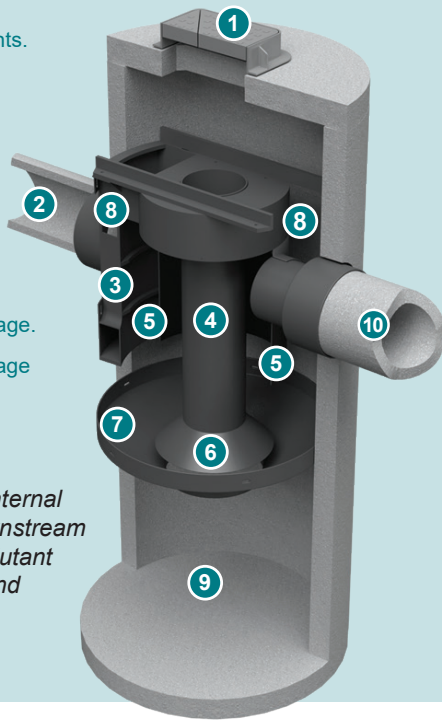

Figure 1 - The unique internal components of the Downstream Defender[®] enhance pollutant removal performance and prevent wash out.

Unique Flow Modifying Components

The Downstream Defender[®] consists of a choice of concrete or HDPE chamber with unique flow modifying internal components. It is these internal components that differentiate the Downstream Defender[®] from catchpits, sedimentation basins or sedimentation sumps. They facilitate advanced hydrodynamic vortex separation by reducing turbulence, lengthening the flow path to increase chamber residence time and introducing shear planes.

The internal components also ensure that the pollutant storage zones are isolated and protected from high flows that could cause pollutant re-entrainment or wash out.

Compared to devices that have poorly designed internal components, the Downstream Defender[®] captures and retains more of the annual pollutant load.

Watch a short video showing the Downstream Defender[®] components and operation at:

<http://www.hydro-int.com/en-gb/products/downstream-defender-0>



Repeatable, Reliable Performance

The Downstream Defender[®] delivers high removal of pollutants through advanced, hydrodynamic separation across a wide range of flows. The device has a proven track record of tackling an assortment of pollutants including:

Sediment (or Total Suspended Solids)



The Downstream Defender[®] is a highly effective sediment/TSS removal device. It can be sized in a number of ways to suit the application and level of protection required (see Table 1). **SuDS Mitigation Index = 0.5.**

Sediment Bound Hydrocarbons (including Polycyclic Aromatic Hydrocarbons - PAHs)



PAHs have low solubility in water and are readily adsorbed onto sediment particles. Effective removal of sediment particles will also ensure the removal of many PAHs.

Gross Pollutants



100% removal of floatable debris, such as food wrappers, Styrofoam cups and drinks cartons

Sediment Bound Heavy Metals and Nutrients



As an efficient device for removal of fine sediment, the Downstream Defender[®] is also effective for the removal of sediment bound pollutants. **SuDS Mitigation Index (Metals) = 0.4.**



Liquid Hydrocarbons



Effective spill containment device that meets the BS EN 858-1:2002 Class I and Class II effluent targets at low flow rates. Note these systems are not considered oil separators according to the BS EN 858-1 and must not be used in applications where full certification is required. **SuDS Mitigation Index = 0.8.**

Design Data

Downstream Defender®

Advanced Hydrodynamic Vortex Separator

No Risk of Pollutant Wash Out

The Downstream Defender® has been specially designed to isolate the pollutant storage zones and is proven to prevent pollutant wash out.

Sizing

The Downstream Defender® can be sized for different treatment goals and objectives.

For design purposes, the selected model's Treatment Flow Rate should be greater than or equal to the site's Water Quality Flow Rate.

The hydraulic capacity of the selected model should be considered with respect to the peak discharge flow rate from the site.

Model Diameter (m)	Treatment Flow Rate - Fine (l/s) ^(a)	Treatment Flow Rate - Coarse (l/s) ^(b)	Hydraulic Capacity (l/s) ^(c)	Minimum Oil Storage Capacity (l)	Minimum Sediment Storage Capacity (m ³) ^(e)	Maximum Headloss at Treatment Flow Rate - Coarse (mm)
1.2	30	38	120	283	0.39	150
1.8	69	85	270	1356	0.73	225
2.55	138	171	542	2535	2.89	300
3.0	190	237	750	4693	3.10	375

Notes:

- Treatment Flow Rate - Fine is based on an annualised removal efficiency of >50% of all particles up to 1000 microns with a mass-median particle size (D_{50}) of 75 microns and a specific gravity of 2.65.
- Treatment Flow Rate - Coarse is based on an annualised removal efficiency of >80% of all particles between 50 and 1000 microns with a mass-median particle size (D_{50}) of 146 microns and a specific gravity of 2.65.
- Maximum flow rate that can pass through the chamber with a maximum headloss of 500mm.
- Alternative sizing based on different sediment grades available on request.
- Additional sediment storage capacity can be provided to extend maintenance intervals if required.

Table 1 - Downstream Defender® design information.

Expert Design Service

Hydro International's professional engineers are on hand to provide free support with the correct sizing and selection of the Downstream Defender® within each drainage design.

We can also provide estimated maintenance intervals, whole life cost estimates and predicted pollutant removal performance.

Call the StormTrain® Hotline on: 01275 337955 or email stormtrain@hydro-int.com

Design Data

Downstream Defender®

Advanced Hydrodynamic Vortex Separator

Setting Out

The Downstream Defender® can accommodate a change in pipe direction to suit site specific requirements. Combined with the high rate internal bypass, this helps to avoid the need for additional manholes on site. Head loss across the chamber is kept to a minimum (see Table 1). The inlet and outlet pipes should be sized in accordance with Table 2 (opposite), and a minimum of 90 degrees between inlet and outlet is required.

Inlet and outlet pipe connections are at the same invert level.

Additional manhole sections can be provided to extend the chamber to meet site cover and invert levels or provide additional pollutant storage where required.

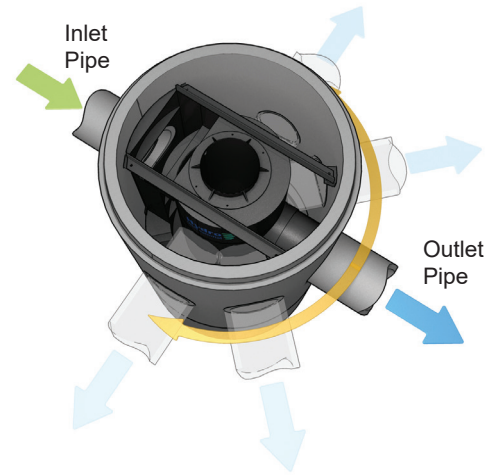

Easy to Install

The Downstream Defender® is delivered to site as a near finished manhole with internal components already installed. Installation is therefore similar to any other manhole installation on site. Full installation guidelines are available.

We can provide structural concrete systems for simple plug-and-play installation or choice of lightweight single and twin wall plastic chambers.

Easy to Maintain

Maintenance of the Downstream Defender® is simple, safe and cost-effective. Maintenance is carried out from the surface, using a standard vacuum tanker and personnel are not required to enter the device.

With a large capacity to store sediments and oils (see Table 1), and with a proven ability to prevent wash out, maintenance intervals can be years rather than months - depending on site conditions. The unit can also be fitted with a [Hydro-Logic™ Smart Monitoring](#) system to alert the site operator when maintenance is required and provide peace of mind that the unit is operating normally at other times.

Additional pollutant storage can be built into the chamber to extend maintenance intervals if required.

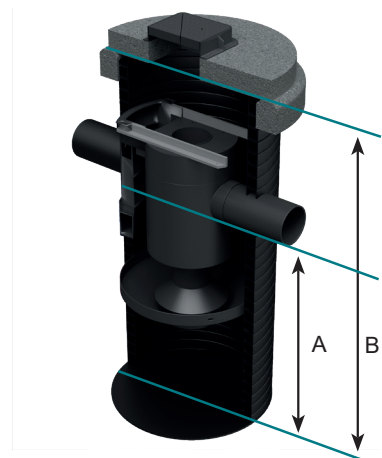
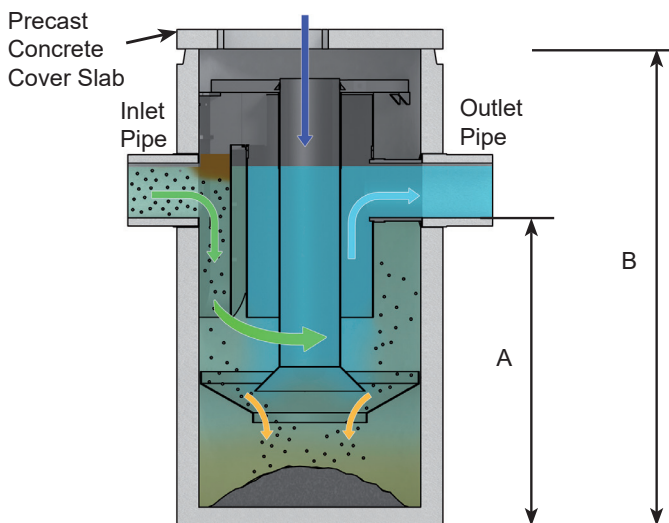

Dimensions and Weights

General arrangement drawings of all units are available for download from:
<http://www.hydro-int.com/en-gb/products/downstream-defender-0>

Model	Material	Chamber Diameter - Internal (mm)	Chamber Diameter - External (mm)	Inlet and Outlet ID (mm)	Depth to invert (m) (A) ⁽¹⁾	Chamber Depth (m) (B) ⁽²⁾	Max Component Lift Weight (kg)
PQL1320.1000	Concrete	1200	1460	300	1.916	2.830	2200
PQL1320.1030	Concrete	1800	2160	450	2.495	4.029	5450
PQL1320.1060	Concrete	2550	2850	600	2.95	4.95	8700
PQL1320.1090	Concrete	3000	3350	750	3.12	5.20	12100
PQL1320.1020	HDPE Single Wall	1188	1200	300	1.55	2.3	140
PQL1320.1051	HDPE Single Wall	1776	1812	500	2.11	3.41	460
PQL1320.1081	HDPE Single Wall	2530	2570	600	2.94	4.8	900
PQL1320.1111	HDPE Single Wall	2974	3000	800	3.13	5.3	1300
PQL1320.1025	HDPE Twin Wall	1200	1300	300	1.56	2.22	400
PQL1320.1055	HDPE Twin Wall	1800	2200	560	2.467	3.75	1100

Notes:
 1) Minimum depth to invert shown. Depth to invert can be increased if required.
 2) Minimum chamber depth shown. Additional sediment storage capacity or increased depth to invert can be provided if required.

Table 2 - Downstream Defender® unit types, dimensions and weights.

The Hydro StormTrain® Series of Surface Water Treatment Devices

The Downstream Defender® is one of the Hydro StormTrain® Series of surface water treatment devices. Each device delivers proven, measurable and repeatable surface water treatment performance. Each can be used independently to meet the specific needs of a site or combined to form a management train. They can be used alongside natural SuDS features to protect, enable or enhance them.

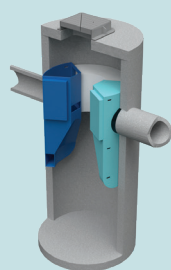

First Defense®
Vortex Separator

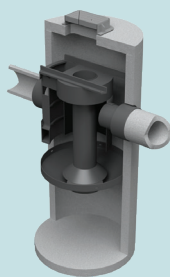

Downstream Defender®
Advanced Hydrodynamic
Vortex Separator

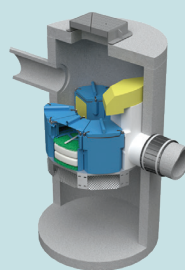

Up-Flo™ Filter
Fluidised Bed Up Flow
Filtration System



Hydro Biofilter™
Biofiltration System

Patent: www.hydro-int.com/patents

Tel: +44 (0)1275 337955 stormtrain@hydro-int.com

Hydro International
 Shearwater House, Clevedon Hall Estate, Victoria Road, Clevedon, BS21 7RD

Downstream Defender® Design Data O/0819

hydro-int.com/stormtrain