

# MNSS Combined Screen

## Product Summary

The MNSS Combined Screen is a robust, reliable inlet works system that combines screening, washing, transport, compaction and dewatering in a single cost-effective standalone solution.

Developed by our UK Wastewater Services team, the MNSS Combined Screen is designed for smaller plants and those facilities that require a more cost-effective screening solution.

The MNSS Combined Screen is easy to install and is ideal for use in municipal or industrial applications that require a simple and robust solution to remove fine solids from a flow.

## Applications

- » Smaller plant inlet works screening, up to 230 l/s per unit.
- » Screening of storm flows at WwTWs and Combined Sewer Overflows (CSOs) to ensure no unscreened sewage is released to watercourses.
- » Packaged plant system available.

## Main Features

1. Perforated stainless steel basket and patented bottom end bearing.
2. Screw conveyor.
3. Control panel.
4. Easily removable wash covers.

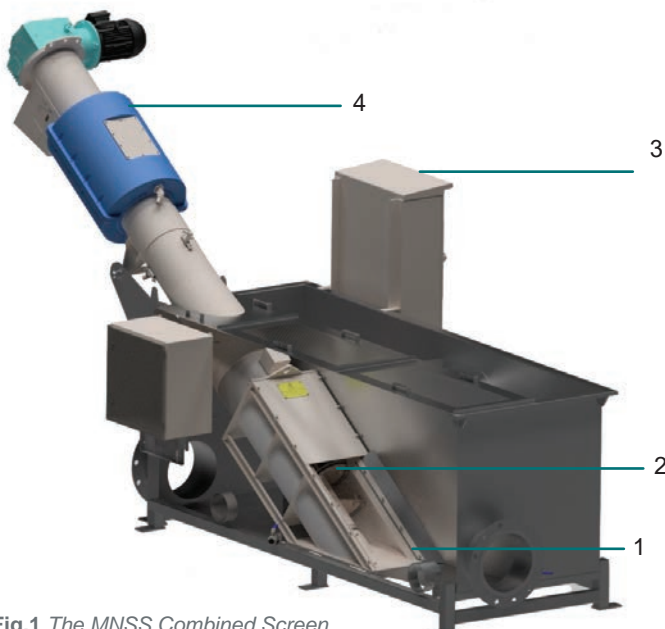

Fig.1 The MNSS Combined Screen

## Technical information

- » Designed to screen flows up to 230 l/s.
- » Available in four channel widths: 300, 400, 500 and 700 mm.
- » Screenings capacity: up to 0.75 m<sup>3</sup>/h.
- » 53 % screening capture performance (independently tested at the National Screenings Efficiency Facility [NSEF]).
- » 3 or 6 mm perforated mesh basket options.
- » Custom screen lengths available on request.
- » Discharge options include fixed chute, swivel chute, Longpac bag & screw conveyor.

## Benefits

### Prevent screenings clogging up treatment plant

The MNSS Combined Screen protects the inlet works by effectively capturing and removing solids carried into the plant in influent.

Removal of these materials at the front of the treatment process protects downstream equipment from abrasion damage.

### Cut screen maintenance

A patented bottom end bearing supports the auger greatly prolonging the life of the brush and reducing maintenance.

### Long component lifetimes—save money on TOTEX

Reduced maintenance goes hand in hand with increased equipment lifetimes—the low-maintenance MNSS Combined Screen provides long component lifetimes, saving plants money on TOTEX costs.



Water & Wastewater Solutions

→ <https://www.hydro-int.com/en-gb/products/mnss-combined-screen>

## Dimensional data

### Installation angle 35 degrees

Model	Min. channel width (mm)	CD & HD (mm)	Max. channel depth (mm)	H (mm)	L1 (mm)	L2 (mm)	Max. water level (mm)
MNSS3	300	2100	870	2720	4870	4115	520
MNSS4	400	2100	870	2720	4950	4214	650
MNSS5	500	2150	925	2780	5125	4385	750
MNSS7	700	2888	1445	3575	6560	5660	780

### Installation angle 45 degrees

Model	Min. channel width (mm)	CD & HD (mm)	Max. channel depth (mm)	H (mm)	L1 (mm)	L2 (mm)	Max. water level (mm)
MNSS3	300	2660	1160	3325	4815	3585	620
MNSS4	400	2660	1160	3325	4866	3660	760
MNSS5	500	2730	1230	3395	5015	3800	860

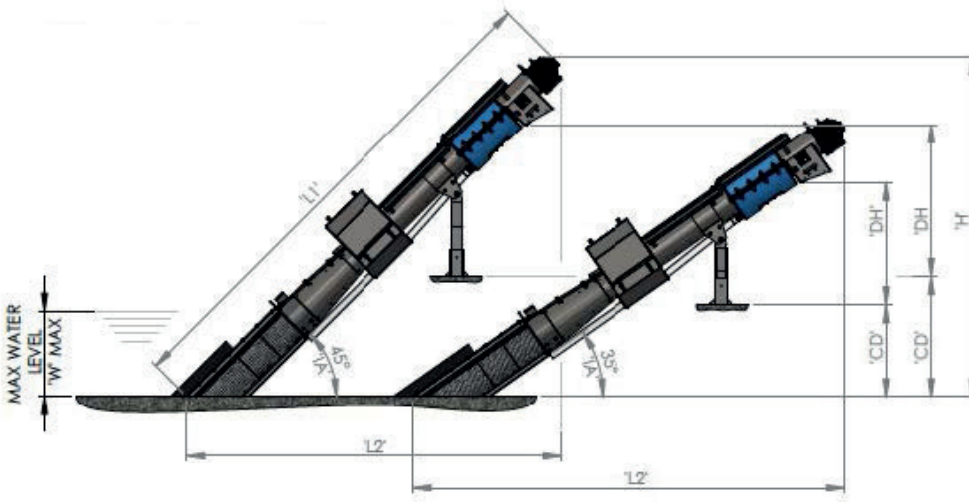

## Operational Data

Flow rate (l/s) (clean water)	Screenings capacity (m <sup>3</sup> /hr)	Dry weight (kg)
50	0.5	450
90	0.5	500
120	0.5	600
230	0.75	850

## M&N UK Wastewater Services

Hydro International's UK Wastewater Services team, M&N Electrical & Mechanical Services is a team of dedicated services professionals operating from five regional offices across the UK.

Our M&N team is the country's largest provider of screen servicing and maintenance, delivering critical support to wastewater treatment plant owners and operators 24 hours a day, 365 days a year.

- » Repair & refurbishment
- » Servicing & maintenance
- » Inlet equipment hire
- » Spares provision
- » Emergency support 24/7

**To find out how our M&N services team can help you keep your inlet works working at peak efficiency please call 01305 821142**



Patent: [www.hydro-int.com/patents](http://www.hydro-int.com/patents)



📍 M&N Electrical & Mechanical Services Ltd  
Unit 12, Southway, Southwell Business Park  
Portland, DT5 2JS

☎ Tel: +44 (0)1305 821142

✉ Email: [sales@mnems.co.uk](mailto:sales@mnems.co.uk)

🌐 Web: [inlet-solutions.co.uk](http://inlet-solutions.co.uk)

**To find out how the MNSS Combined Screen can help you simplify your inlet works processes and improve your plant's performance call 01305 821142 or visit:**

→ <https://www.hydro-int.com/en-gb/products/mnss-combined-screen>