



SAFETY AT THE HIGHEST LEVEL

# The Safety Solution for Engineered Life Lines



- CONFORMS TO EN 795:2012, CEN TS 16415:2013, ANSI Z359 & CSA Z259 AND PATENT PROTECTED BY GB 2389386
- FOR ROOF INSTALLATION AND HORIZONTAL OR OVERHEAD APPLICATIONS ON STRUCTURES
- ALLOWS SPANS UP TO 12M AND 3 USERS
- SUITABLE FOR USE ON MULTIPLE ROOF TYPES

## Working at Height

Legislation demands that any person working at height needs to be protected to prevent them from falling. Ideally working at height should be avoided altogether but in many instances it is unavoidable. When this is the case the preferred solution is to implement a collective protection system such as guardrail but sometimes this is not possible, perhaps when a building layout is

inappropriate or where aesthetics may be compromised; consequently, a personal protection solution must be implemented. A wire based horizontal life line system is a flexible, cost effective option for the protection of workers at height, especially so if access to a roof top is an irregular occurrence.

## KeeLine® Fall Protection System



The **KEELINE** horizontal lifeline system is designed to provide safe access to any area of a roof by allowing workers to be permanently attached to the line at all times and be able to freely move around the roof surface. The system utilises 8mm grade 316 stainless steel wire and allow spans of up to 12m between posts and can be utilised by up to three users at any one time.

The **KEELINE** system incorporates an inline shock absorber that minimises loads applied to both the user and the building in event of a fall. The design has been configured and tested for use on a variety of roof types e.g. standing seam, membrane, metal profile using either “top fix” anchors or a “through fix” anchor (**POSTANKA**) where fixing to the main building structure is preferred. Equally, **KEELINE** is available for mounting directly to concrete, steel, brick or stonework in either horizontal or overhead applications.

**KEELINE** has been tested and conforms to the requirements of EN795 2012, CEN TS 16415:2013, ANSI Z359 and CSA Z259.



# KeeLine® for Roofs

**KEELINE** now incorporates a redesigned post and base plate for use on membrane roofs. The new design will allow easier and quicker installation but still utilises the same range of brackets as the options for tiled, standing seam and metal profile roofs.

## Upright Post for Membrane Roofs

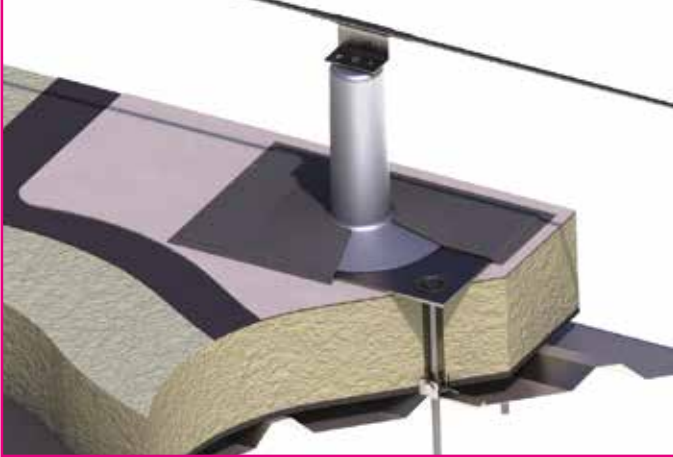

## Upright Posts for Tiled Roofs

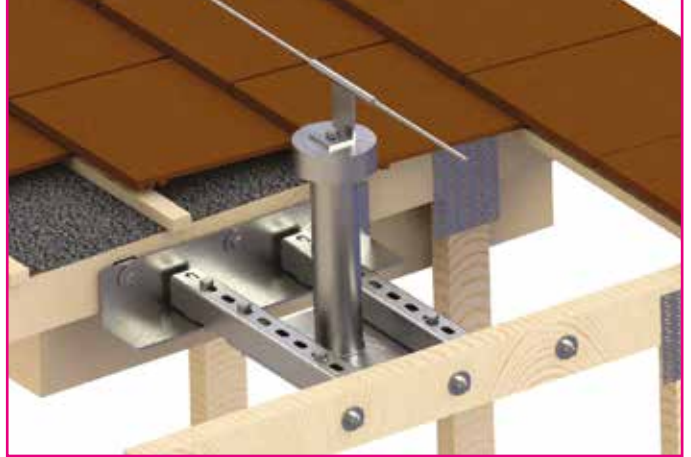

## Upright Post for Standing Seam Roofs

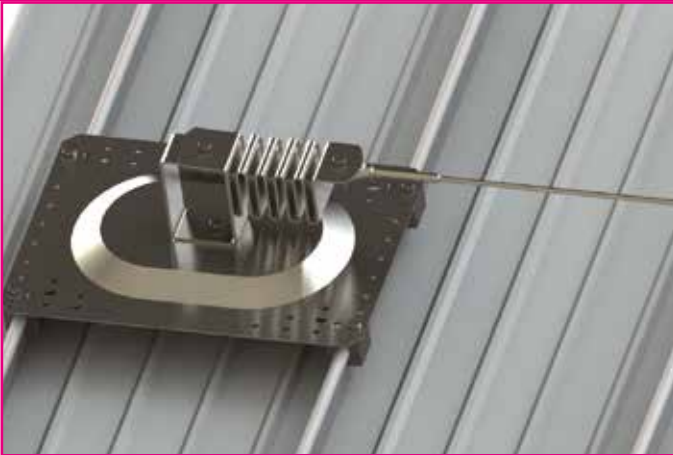

## Upright Posts for Profiled Sheet Roofs

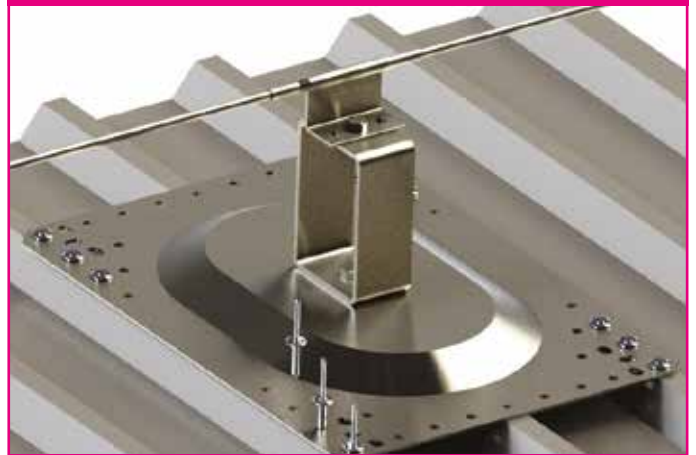

## KeeLine® Brackets for both Roofs & Structures

### Intermediate Bracket

One-piece bracket for intermediate supports



### Corner Bracket 90°

Accommodates internal or external bends



### Corner Bracket 45°

Accommodates internal or external bends



## KeeLine Brackets for Structures Only

### Extremity Bracket

LINE-XBRKT



### Structural Corner

CNR-90-W



## KeeLine Universal Components

### Wire



8mm dia 7x7 IWRC Gr.  
316 Stainless Steel.

Available cut to length or  
1000m reels.

### Absorber

Used at both ends  
of the system,  
minimises loads  
on structure to  
below 10 kN.



### Tension Indicator



Used at start of system  
(or both ends for systems  
over 150m).

Indicates when system is  
correctly tensioned.

Available Swaged or  
Swageless.

### KeeLine® Traveller

Allows user to attach at any  
point on system.

No moving parts.

Passes corners and  
intermediates without  
needing to detach from the  
system.



### Swage End Fitting



Used to terminate system.

Available Swaged or  
Swageless.

## KeeLine Overhead Unique Component

### KeeLine Overhead Traveller



# Postanka®

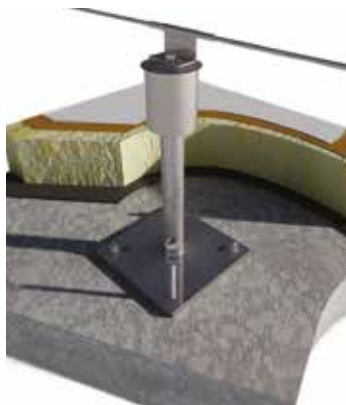

Kee Safety's **POSTANKA** range of fabricated, hot dipped galvanised anchors are designed using a standard calculation program to the requirements of EN 795 Class A2 or OSHA's 5000 lbs (22.2kN) requirement.

Used where it is preferable to mount directly to a buildings structure, e.g. on traditional sloping roofs or onto concrete roof decks, for example on green roofs.

**POSTANKA** anchors are available in standard sizes but are more typically designed to suit customer's specific application.

**POSTANKA** anchors are available in two styles.

## Type 3 Postanka



Designed to clamp around either suitable wooden or steel beams and features a solid adjustable height pedestal.

## Type 6 Postanka



A solid central pedestal welded to a 15mm thick base plate.  
  
Available with multiple fixing options

As standard **POSTANKA** anchors are tapped to accept the **KEELINE** system or alternatively for use with Kee Safety's **RINGANKA** eyebolt range to produce single point anchor points, for fall protection or rope access.

Weather caps are also available.

As the **POSTANKA** range can be designed to suit a particular application, anchors can be produced for mounting other products for example **KEE WALK** or solar panels.

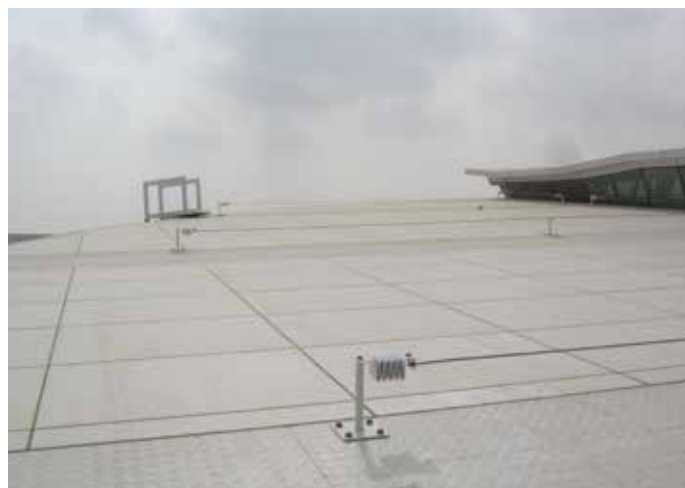

## KeeLine® Overhead



- Higher pre-tension than standard **KEELINE** systems reduces line sag and cable deflection
- Supports multiple users
- Durable electro-polished Gr.316 stainless steel brackets and traveller
- Meets the requirements of international standards.
- Permanently attached, Gr.316 stainless steel, smooth running two wheeled traveller easily passes intermediate brackets
- **KEELINE in-line shock absorber limits end loads to structure**
- **Suitable for single or multiple span systems**
- **Spans of up to 24m in between supports**
- End and intermediate brackets are installed directly to suitable structures, including steel or concrete.



# Why purchase KeeLine®

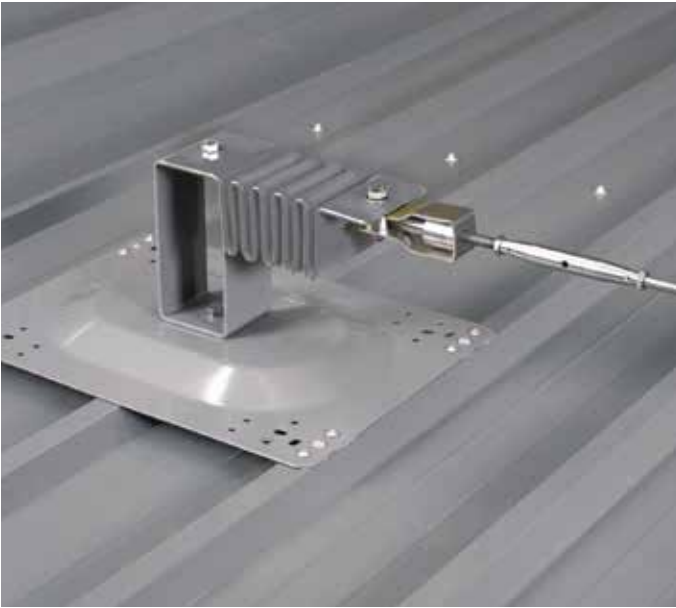

## Features

- Compliant with EN 795 2012, CEN TS 16415:2013, ANSI Z359 & CSA Z259
- Tested on multiple roof types
- Maximum span between posts of 12m
- Traveller can pass the whole length of the system without having to be detached at any point
- Open style, low profile post designed to suit metal profile and standing seam roofs.
- Specific membrane roof base plate and post allows simple weathering installation
- Galvanised mild steel or stainless steel parts
- Base plates allow multiple fixing options

## Benefits

- Proven system meeting all current legislative requirements
- Safety assurance that the system is fully functional on all approved surfaces
- Minimises the number of posts and roof fixings required
- The user is always connected to the system
- Posts designed to deploy and deform in event of a fall, minimising the load being applied to the building to below 10Kn
- Saves installation time and thereby reduces project costs.
- Long term corrosion resistance
- Easy ordering, reduced stockholding and less complexity for customers

**KeeLine®**

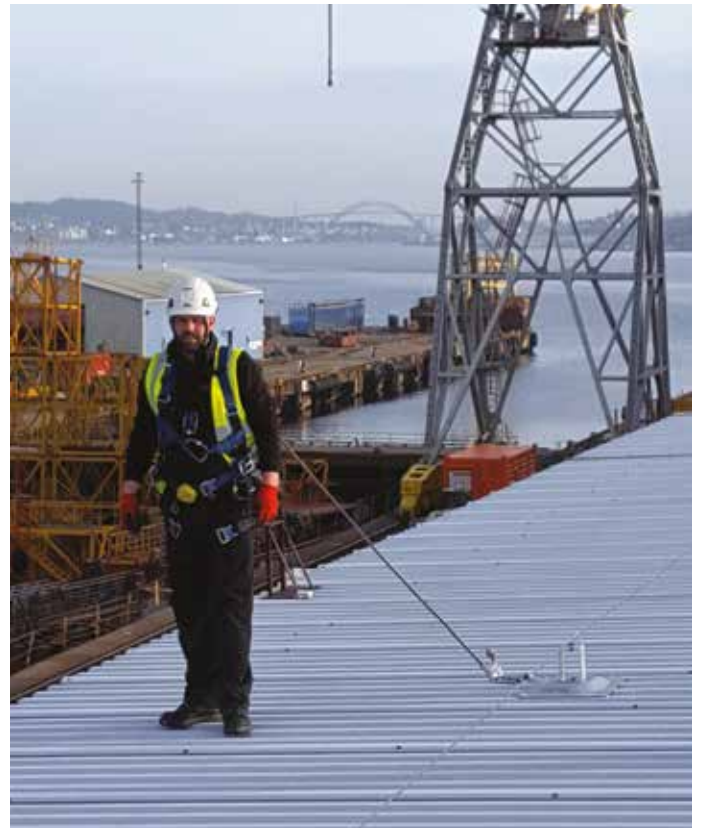

Kee Safety Ltd.  
Cradley Business Park  
Overend Road  
Cradley Heath  
West Midlands  
B64 7DW

Tel: +44 (0) 1384 632188  
Fax: +44 (0) 1384 632192

Email: [sales@keesafety.com](mailto:sales@keesafety.com)  
[www.keesafety.com](http://www.keesafety.com)