

**COLD WATER
STORAGE CONTROL**



AYLESBURY™

FLOAT VALVE RANGE



Keraflo have manufactured top quality, delayed action float valves in the UK for over 30 years. The Aylesbury™ range is synonymous with float valve excellence with tens of thousands of products in continual use in demanding domestic, commercial and industrial applications throughout the UK and around the world.

The Aylesbury™ Float Valve Range

Aylesbury valves are designed to provide an accurate and efficient method of controlling the level of stored cold water in tanks with and without raised float valve chambers. Manufactured in the UK in a Lloyd's Register Quality Assured manufacturing facility, they are constructed to operate over long periods without the need for maintenance. In addition all valves are WRAS approved and come with a 5 year warranty.

The valves are easy to install with an "up and over" discharge arrangement which assists in facilitating Type AA, AB, AF, or AG air gap requirements under the Water Regulations.

The Aylesbury range is ideal for pumped systems as the open to closed "on/off" valve operation avoids pump hunting and water hammer. The set water level is unaffected by pressure fluctuation and there is no seat or washer to wear.



The Aylesbury Delayed Action Float Valve Range

Non adjustable opening / closing operating differential of approximately 75mm.

'K' Type	Page 4
'KAX' Type	Page 5

Fully variable opening and closing operating differential of up to 1820mm and longer on request.

'KB' Type	Page 6
'KP' Type	Page 8

Benefits of Keraflo's Aylesbury Float Valve Range

Maintenance Free:

Designed to operate for long periods without maintenance.

Backsiphonage Protection:

"Up and Over discharge" to BS1212 part 2 helps to facilitate Air Gap compliance.

Extended Durability:

Non-wearing ceramic disc seal in a DZR brass housing.

Virtually Indestructible:

The heart of the valve incorporates pressure compensated rotating ceramic discs which are aligned in the open position.

Revolutionary Shaped Puncture Proof Float:

Made from Polyethylene closed cell foam which is CFC free air retardant and chemically and biologically inert. This radical design virtually eliminates stress on the tank wall fixing point.

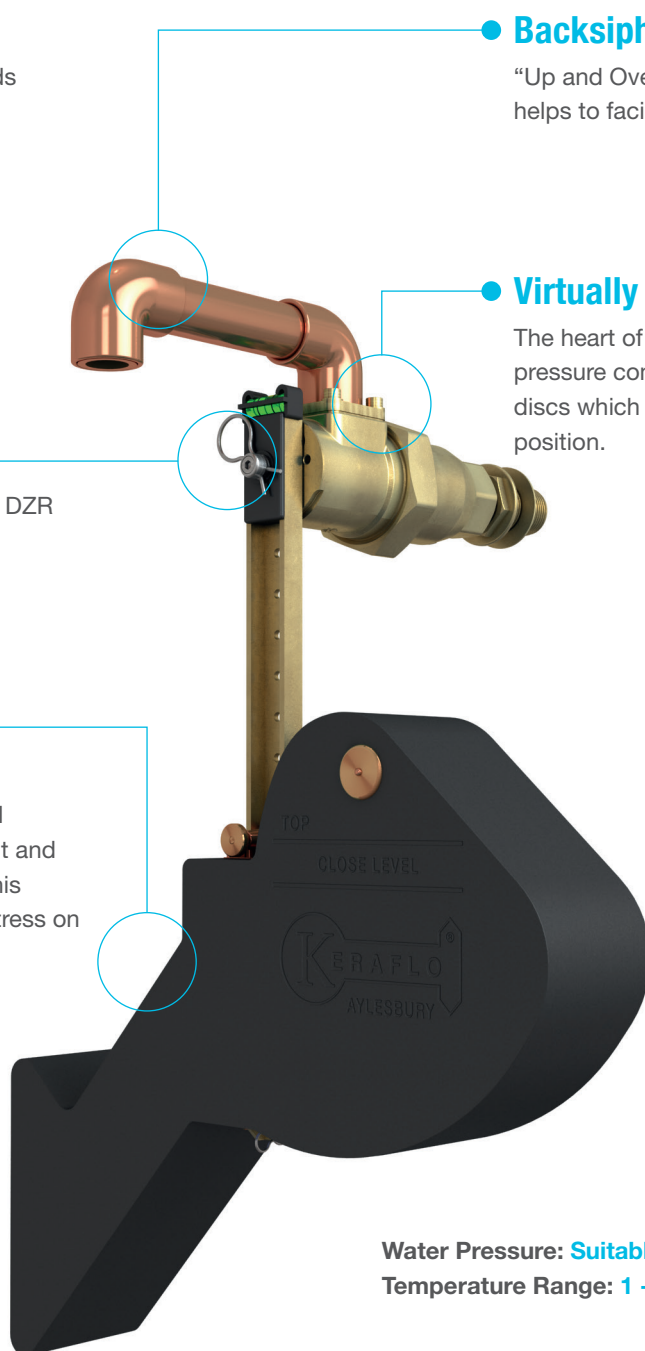

Water Pressure: Suitable for 0 - 10 Bar.
Temperature Range: 1 - 60 °C.

- Ideal for pumped systems
- Reduces Legionellae risk
- No valve bounce
- No dribble
- No water hammer
- Improves water turnover
- Saves energy with positive pump control
- Maximises tank capacity
- Fixed & variable level differential models
- Full flow during fill

The Aylesbury 'K' Type

- Delayed Action Float Valve
- Suitable for tanks without raised valve chambers

The weighted key-shaped float which is supplied with Aylesbury 'K' Type float valves can be accurately set in a number of positions on the brass float arm, actuating the valve at a predetermined difference in water level, driving it fully open or fully closed without water hammer. This positive action avoids dribble, reduces noise and allows full flow until the selected closed level is reached.

Inherent in the design is a non-adjustable operating differential in water level between opening and closing of approximately 75mm. Also available in stainless steel for use in demanding environments such as desalination plants and sea water.

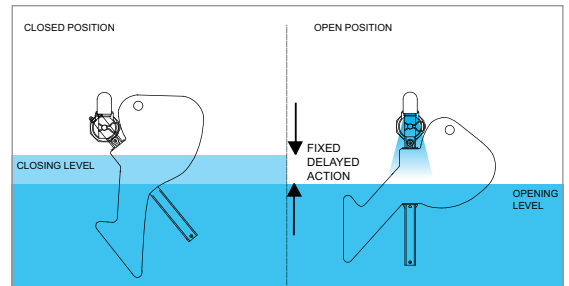

Sizes for 'K' Type Delayed Action Float Valve

	½" (15mm)	¾" (20mm)	1" (25mm)	1 ¼" (32mm)	1 ½" (40mm)	2" (50mm)
Standard Flow (SF)	✓	✓	✓	✓		✓
High Flow (SF)					✓	

	2" (50mm)	2 ½" (65mm)	3" (80mm)
Standard Flow (SF)		✓	
High Flow (SF)	✓		
Reduced Bore			✓

Larger sizes, opposite handed and stainless steel available on request

Aylesbury 'KAX' Type

- Delayed Action Float Valve
- Primarily for tanks with raised valve chambers

Identical in operation to the 'K' Type, the Aylesbury 'KAX' Type Valves have extended drops and are suitable for raised valve chambers. They are primarily designed to fit into chambers or boxes in the covers of tanks calling for Air Gaps or where maximum tank capacity is required.

To assist with compliance of Air Gap requirements the valve discharge is further raised above the centre line. The 'KAX' is especially suitable for Type AA & AB Air Gaps.

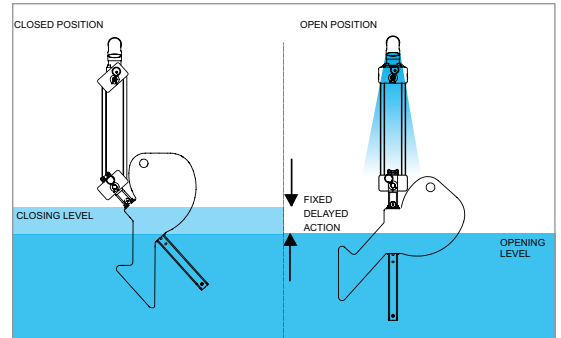

Sizes for 'KAX' Type Delayed Action Float Valve

	¾" (20mm)	1" (25mm)	1 ¼" (32mm)	1 ½" (40mm)	2" (50mm)
Standard Flow (SF)	✓	✓	✓		✓
High Flow (SF)				✓	

	2" (50mm)	2 ½" (65mm)	3" (80mm)
Standard Flow (SF)		✓	
High Flow (SF)	✓		
Reduced Bore			✓

Larger sizes, opposite handed and stainless steel available on request

The Aylesbury 'KB' Type

- Fully Variable Delayed Action Float Valve
- Suitable for tanks with or without raised valve chambers

The valve is operated by a transfer of weight in an actuator tube which causes the valve to open or close. The arrangement of the float and buoy assembly produces a delayed change of balance in the actuator as the water level alters. The total assembly is relatively light with no pressure related stresses. As a result the valve does not require any supporting structure.

Aylesbury 'KB' Type valves have a variable delayed action and feature a chain in place of a rigid float arm enabling virtually unlimited opening and closing levels. This allows for a considerable drop from the valve to the water level, overcoming issues associated with drop arms.

The versatility of the Aylesbury 'KB' Type makes it suitable for installation either directly into a tank or into a raised valve chamber particularly where Air Gaps are required. Changes in water levels and differentials can be made quickly by the installer or maintenance engineer without tools.

This feature is particularly useful where water demand changes either due to seasonal factors, building occupancy or where the commissioning of a facility is phased, as it reduces the risks associated with excess water being stored for too long.

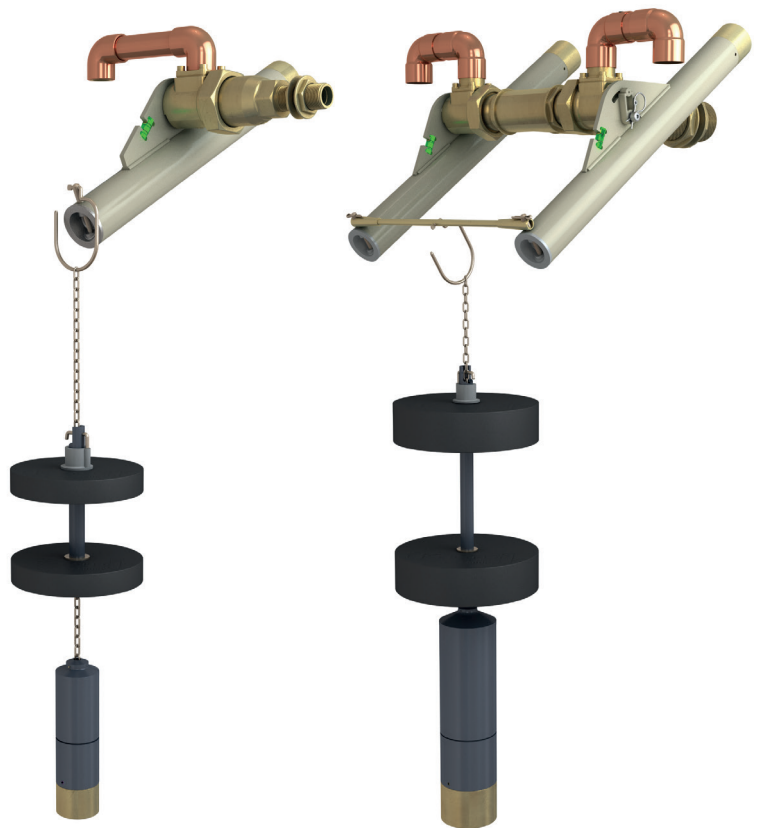

Sizes for 'KB' Type Delayed Action Float Valve

	3/4" (20mm)	1" (25mm)	1 1/4" (32mm)	1 1/2" (40mm)	2" (50mm)	2 1/2" (65mm)	3" (80mm)
Standard Flow (SF)	✓	✓	✓	✓		✓	
High Flow (SF)				✓	✓		
Reduced Bore (RB)							✓

Larger sizes, opposite handed and stainless steel available on request

The Aylesbury 'KB' Type

Applications

This unique valve is ideal for use with pumped systems, water treatment plants and many other applications including:

- Industrial tanks
- Rain (grey) water tanks and reservoirs
- Pumped systems
- Industrial feed and expansion tanks
- Underground tanks
- Process tanks

For more information on the applications, call our technical support team or visit www.keraflo.co.uk/applications

The flexibility of 'KB' valves can assist with improving water quality where buildings are partially commissioned or occupancy varies, at different times of the year.

Air Gaps for Industrial Tanks

The 'KB' Type is ideal for fitting into a tank without a lid or raised valve chamber and where the vertical drop from the valve to the water level may be considerable.

Pumped Systems

The adjustable and potentially large difference between opening and closing levels can allow a large volume of water to be admitted to the tank each filling cycle. Pumps and pump sets are often controlled to run for a minimum of 3 minutes. If the water demand is satisfied before this time and an auxiliary hydraulic accumulator is not fitted, the pumps will run against a closed valve at zero efficiency.

The fill volume can be set to equal or exceed this volume to ensure the pump/s run for at least 3 minutes. Where a pump set is used solely for transferring water from a break tank to an elevated storage tank the 'KB' Valve can dispense with the need for an auxiliary hydraulic accumulator.

Pump efficiency and initial sizing can be further enhanced using a float valve with little internal resistance. Consequently the High Flow version is often better suited to these applications than the Standard Flow version which is ideal for mains water pressure applications.

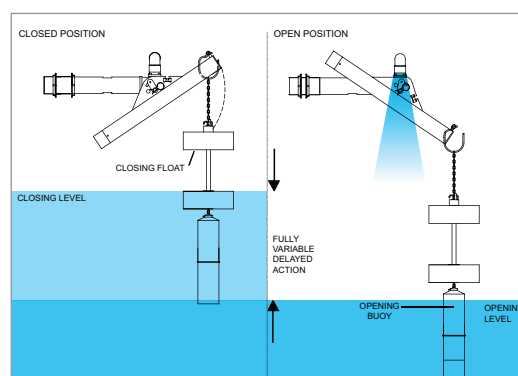

Aylesbury 'KP' Type Float Valve Kit

- Fully Variable Delayed Action Float Valve
- Suitable for tanks with or without raised valve chambers

The 'KP' Type Float Valve Kit comprises an in-line control valve together with an Aylesbury 'KB' Type Valve acting as a pilot. The pilot valve offers fully variable delayed action opening and closing water level settings making this ideal for mains or pumped systems.



PILOT VALVES

High Kv Value

The standard 'KP' Control Valve offers excellent flow rate performance.

Raised Valve Chamber

Can be small as it only has to accommodate a 3/4" KB valve and discharge assembly.

Facilitates Air Gaps

The Aylesbury 'KB' Valve is supplied with a 2m long adjustable chain as standard allowing the closing level to be set below any combination of Weir Slot, Overflow and/or Warning Device.

Quiet Operation

Aylesbury valves are quieter than conventional valves due to the elimination of Water Hammer, Valve Bounce, "Hiss" and Dribble.

Accessibility

An externally mounted Control Valve can be easily - inspected, adjusted and - if required - serviced. Re-chlorination of the tank is not necessary provided the tank lid is not removed.

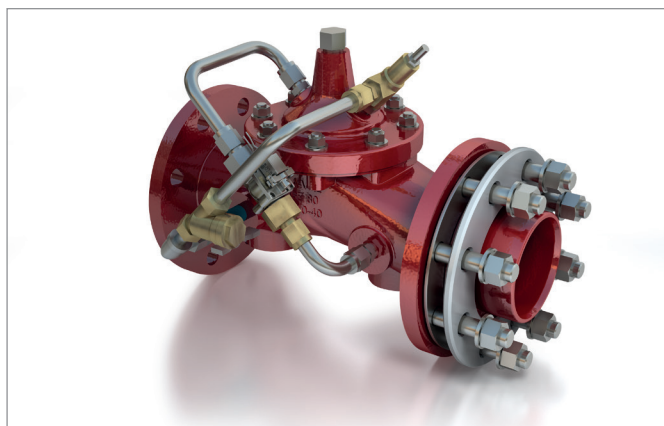

CONTROL VALVE

Optional Extra

- Upstream Pressure Sustaining Regulator - the Control Valve regulates itself to leave the desired minimum upstream pressure (Adjustable 1 - 6 Bar). This can also be used to provide a constant flow rate.

Sizes for 'KP' Type Fully Variable Delayed Action Float Valve Kit

1 1/2" (40mm)	2" (50mm)	2 1/2" (65mm)	3" (80mm)	4" (100mm)	6" (150mm)	8" (200mm)
✓	✓	✓	✓	✓	✓	✓

Larger sizes, opposite handed and stainless steel available on request

Aylesbury 'KP' Type Float Valve

Benefits

- No Water Hammer
- Full Flow During Fill
- Maximises Tank Capacity
- Maintenance Free
- No backing plate required
- Suitable for all types of Air Gap applications
- No Valve Bounce
- No Dribble
- Delayed Action
- Tank Wall Stress negligible
- Ideal for Fire Sprinkler Systems

Flexibility and ease of Installation

Conventional Float Valves above 3" are heavy and cumbersome often necessitating a two person installation. When the 'KP' Control Valve is mounted outside the tank at floor level, no heavy lifting is required.

The Control Valve can be mounted in one of four positions:

- Vertically in the pipe work (preferred option)
- Outside the tank at floor level
- Outside the tank above the tank water level
- Inside the tank above the tank water level

Multiple Discharges

To reduce the risk of stagnation, two or more discharges can be connected to the outlet of the control valve. Since the Filling Pipe is only subjected to low pressure, thin wall PVC pipe can be used. The 'KP' Valve can also be configured to service twin/partitioned tanks.

Shallow Tanks

'KP' Valves can operate in tanks as shallow as 1 metre in depth.

Deep Tanks

The standard Aylesbury 'KB' Pilot valve enables an opening level 2m below the inlet level. A longer chain can be supplied if required.

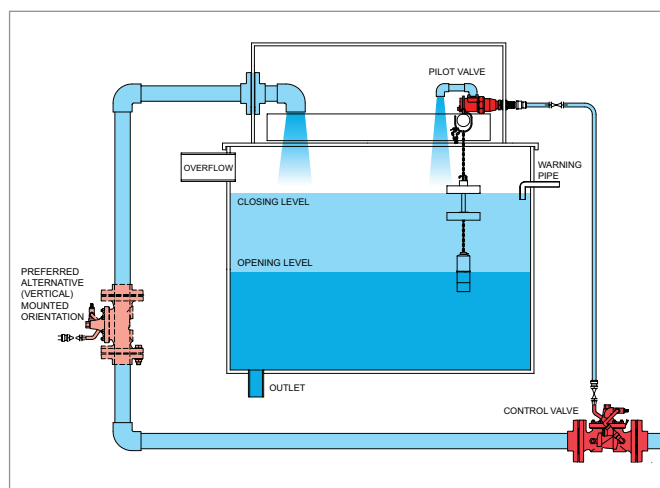

'KP' Typical Standard Tank Installation

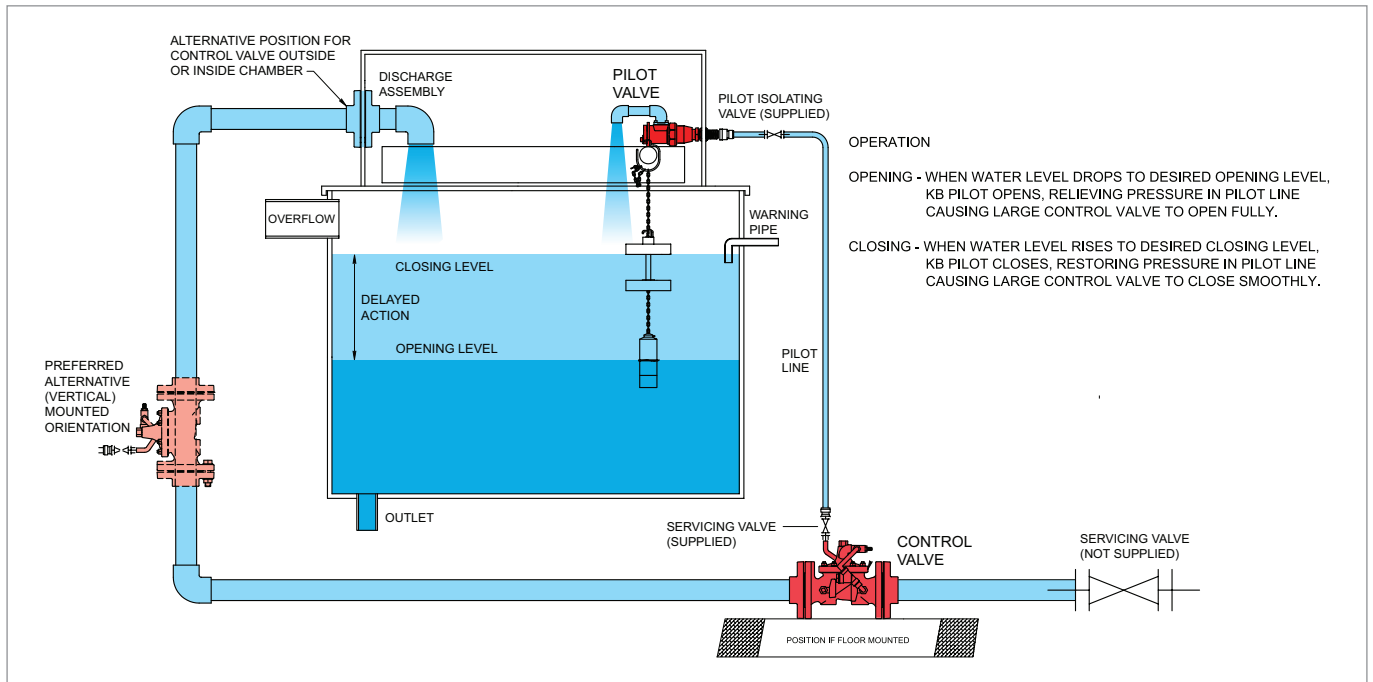

'KP' Typical Twin Tank Installation

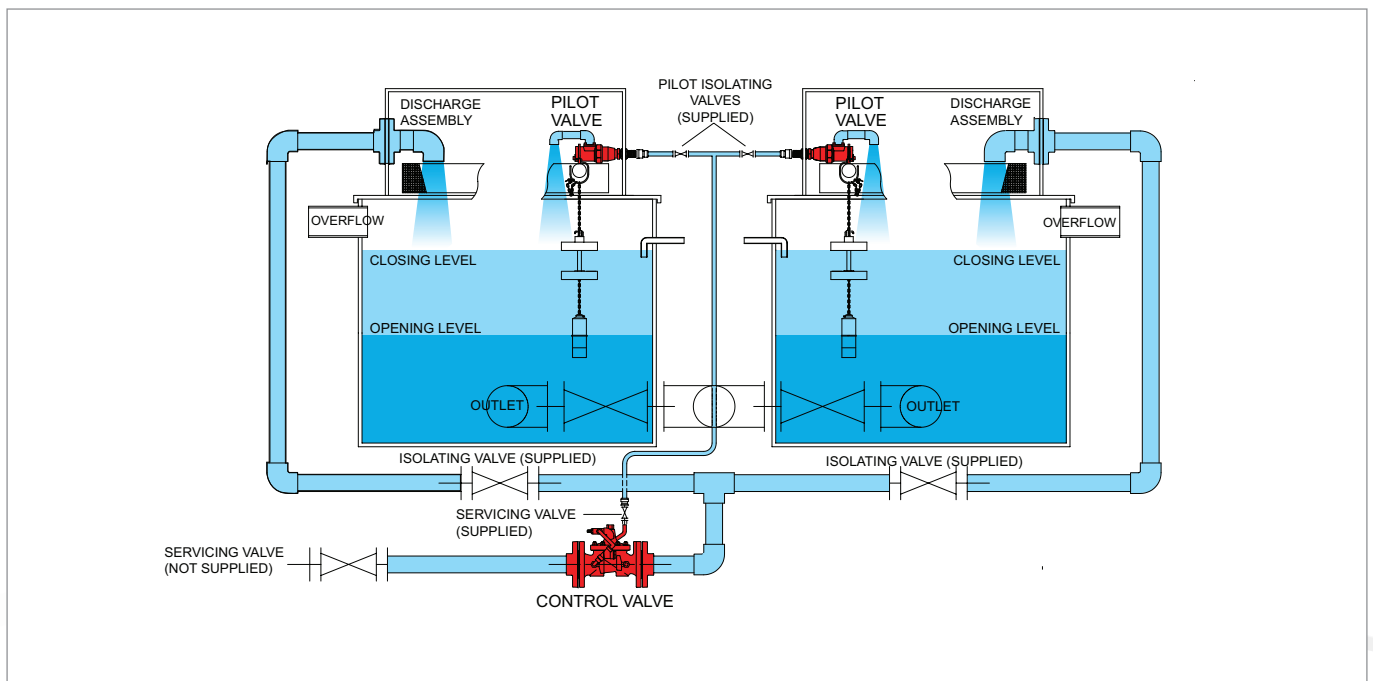

Specification Support

Keraflo's National Sales Team provide the very highest levels of technical advice and specification support at local level, including guidance regarding Water Regulations compliance.

Water Regulations

Keraflo's 20 page Guide to the Water Supply Regulations highlights the design implications of this legislation with regard to float valves. This highly informative A4 document explains Air Gap types, fluid categories of risk and explains in detail the system design implications of the most common Air Gap types.

A copy of this Guide is available on request or may be downloaded from our website.



CPD Seminars

Keraflo offers a CPD seminar presentation entitled UK Water Regulations which addresses a range of specification issues including back flow protection and their implications on float valves. To enquire about these seminars please contact us.



Downloadable CAD & PDF Product Drawings and Fitting Instructions

A wide range of Keraflo product drawings are available on request or may be downloaded in PDF or CAD format from our website, www.keraflo.co.uk.

Keraflo and Aylesbury are registered trade marks. The Aylesbury valve is a patented product. Keraflo Ltd reserve the right to alter designs without prior notice.

TANKTRONIC® DIGITAL TANK MANAGEMENT



Main Control Unit

Tanktronic monitors water levels and temperature. It can also manage and control tank filling, enabling users to vary tank capacity to match demand.



S-Module

An expansion module that boosts Tanktronic's control capacity. Additional pilot valves and 3rd party devices can be connected to the system.



Sensor

The Sensor monitors both water pressure and temperature. The unit is provided pre-fitted to a vent box for rapid mounting and wiring connection.



Keraflo Limited, Unit 1, Woodley Park Estate, 56-69 Reading Road,
Woodley, Reading, Berkshire, RG5 3AN, UK

0118 921 9920 | info@keraflo.co.uk | www.keraflo.co.uk

A subsidiary of Davidson Holdings Ltd.

