

NOTES

1. DO NOT SCALE FROM THIS DRAWING
2. THIS DRAWING IS CONSTRUCTED USING LAYERS WHICH CAN BE TURNED ON OR OFF AS REQUIRED
3. DUE TO SETTLEMENT ALL TREES SHOULD BE RE-TENSIONED AFTER PLANTING

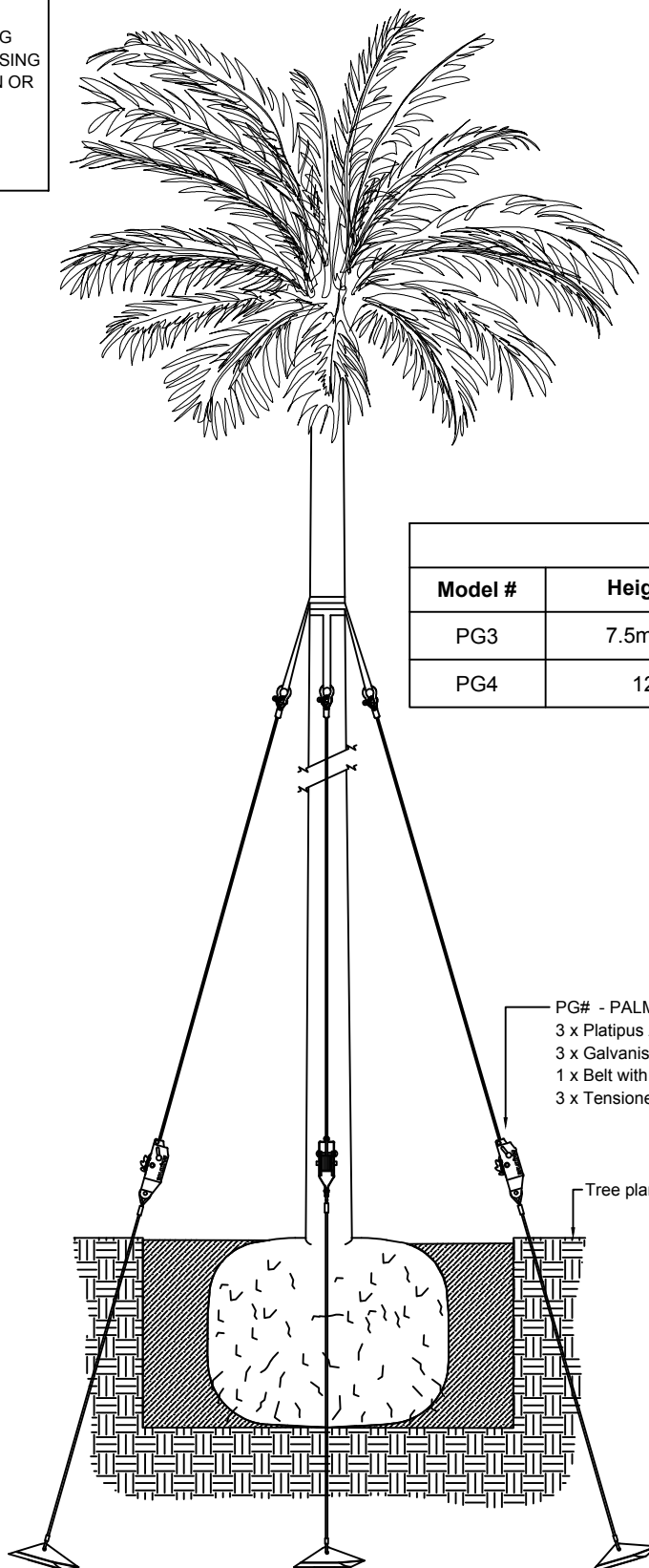

Model List		
Model #	Height - m	Circumference - cm
PG3	7.5m - 12m	150cm - 230cm
PG4	12m+	Over 230cm

- PG# - PALM GUY FIXING SYSTEM
- 3 x Platipus Aluminium Alloy Anchors attached to Ratchet Tensioners
- 3 x Galvanised Wire Guy with Shackles
- 1 x Belt with Tensioner and Three Loops
- 3 x Tensioner Shrouds

Tree planted at nursery line

© 2017, PLATIPUS ANCHORS

PALM GUY FIXING SYSTEM

DRAWN/DATE
C Matthews 16JUNE17

CHECKED/DATE
C Matthews 16JUNE17

APPROVED/DATE

This guidance is based on our understanding of your requirements and no reliance should be placed on any specifications, sketches, plans or drawings provided by us or our representatives. You should seek appropriate advice from your own professional advisers since we shall not be liable for any loss or damage, consequential or otherwise, for any claims made by any third party for design guidance given by us or our representatives

PLATIPUS
TREE ANCHORING SYSTEMS

Platipus Anchors Limited,
Kingsfield Business Centre, Philanthropic Road,
Redhill RH1 4DP, England.
Tel: +44 (0) 1737 762300 Fax: +44 (0) 1737 773395
Web: www.platipus-anchors.com
E-Mail: info@platipus-anchors.com

DRAWING NUMBER:

UK 400 - 9

© COPYRIGHT PLATIPUS ANCHORS, LTD.
This drawing has copyright and may not be copied in whole or part or used for any purpose other than that for which it is supplied without express written consent.