

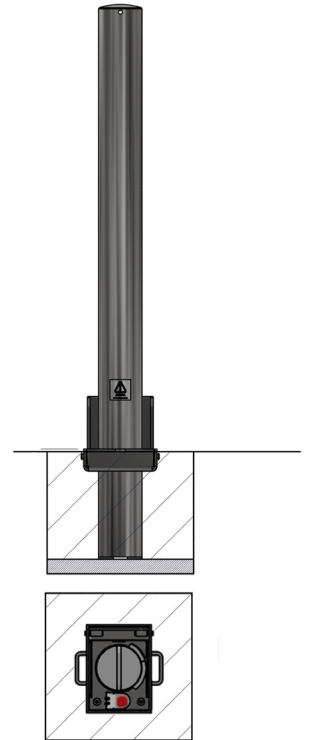

RGP 745

745mm

Galvanised or Galvanised & Colour



The RGP (removable ground post) offers a highly effective and robust way to protect premises and vehicles. The post is 745mm above ground, when removed the socket is covered using the integral lid. The post is lockable by rotating the post 45° and then pressing the high-security push button 7-pin security lock. The post is unlocked using the supplied key, rotated and then removed.

The RGP is ideal for protecting vehicle forecourts, commercial premises, car parks and domestic driveways.

Tested and approved by Sold Secure.

This product has achieved Secure by Design status.

Part Number	Description	Lift Weight (kg)	Weight (kg)
138 100 736	76mm Galvanised - Removable	6kg	12kg
138 100 737Y	76mm Galvanised & Yellow - Removable	6kg	12kg
138 100 751	90mm Galvanised - Removable	7kg	15kg
138 100 752Y	90mm Galvanised & Yellow - Removable	7kg	15kg
138 121 329K	101mm Galvanised - Removable	8kg	17kg
138 121 330KY	101mm Galvanised & Yellow - Removable	8kg	17kg
138 121 422K	114mm Galvanised - Removable	10kg	19kg
138 121 422KY	114mm Galvanised & Yellow - Removable	10kg	19kg
138 100 723	60mm x 60mm Galvanised - Removable	6kg	12kg
138 100 725	70mm x 70mm Galvanised - Removable	7kg	15kg
138 100 763	90mm x 90mm Galvanised - Removable	9kg	18kg



Secured by Design



Police Preferred Specification

Product details

- 745mm - (above ground)
- Socket - 270mm (below ground)
- 3mm wall thickness
- Red/white chevron tape available extra
- Other colours available on request

Installation & use

Bolt down to a suitable concrete surface.
 Telescopic, removable and concrete in are supplied with welded fixing spikes to ensure firm ground anchorage into concrete.
 Telescopic, removable and concrete in require a suitable excavated hole for installing into concrete.
 Products are guaranteed for 12 months (if installed and used correctly).



www.autopa.co.uk
 +44 (0)1788 550556

AUTOPA Limited
 Cottage Leap, Rugby, Warwickshire CV21 3XP

