

DIRECT FIRED GAS HEATERS INSTALLATION AND OPERATING MANUAL



INDEX	Section
Introduction-----	1
General Requirements -----	2
Ventilation Requirements -----	3
Technical Data -----	4
Installation Details -----	5
Commissioning & Testing -----	6
Servicing -----	7
Troubleshooting -----	8
Parts Removal & Replacement -----	9
Spare Parts -----	10
User & Operating Instructions -----	11

WARNINGS

- 1 This appliance must only be installed by a competent person in accordance with the requirements of the Codes of Practice or the rules in force.
- 2 All external wiring MUST comply with the current IEE wiring regulations.
- 3 Warning this appliance must be earthed.

1. Introduction.

1: Introduction

The Econoair DF Direct Fired air handling range is designed for economical and efficient operation to give clean and healthy environmental conditions, with constant even temperature control. It is available either as a DF MUA – make up air unit or, DF VAV – variable air volume unit.

DF MUA

MUA heaters are fitted with a double inlet multivane fan. It may be free blowing into a distribution head or in conjunction with duct work. The heater has no heat exchanger, all the products of combustion being discharged into the heated space, thus no flue is necessary.

The heater is fitted with the standard NG2 burner (see diagram 7) and profile plate which has been specially designed so that a proportion of the incoming air is forced into contact with the flame to ensure rapid mixing with uniform heating to the desired temperature and allows a high turn-down. The burner is fully modulating which provides the optimum heat required at maximum efficiency, so reducing running costs.

DF VAV

VAV heaters are fitted with a double inlet multivane fan. It may be free blowing into a distribution head or in conjunction with duct work. The heater has no heat exchanger, all the products of combustion being discharged into the heated space, thus no flue is necessary.

The heater is fitted with the *Uq \ cã Áox* burner with NG1 burner (see diagram 6), replacing the standard NG2 and profile plate arrangement giving similar combustion properties but with the advantage of providing its own combustion air. The air flow through the heater is controlled by an inverter connected to the main fan motor. Various types of inputs can be fed into the microprocessor controller varying the air volume of the unit for a variety of applications.

Gas burner assembly

Each burner is built up from modular components to give the required heat duty. The burner consists of a heavy duty iron body which forms the fuel gas manifold, fitted with stainless steel mixing plates carefully designed to withstand the stresses of thermal expansion. The mixing plates are perforated to ensure intimate and progressive mixing of the incoming air with the fuel gas at all firing rates.

Heater casing

The heater casing comprises of an aluminium Pentapost frame construction mounted onto a channel base frame and fitted with panels which can be either pre-insulated 25mm thick (or 50mm optional) expanded polyurethane foam or single outer skin, coated steel/aluzinc/galvanised, or outer skin coated steel/aluzinc/galvanised with rockwool or melamine foam insulation, with an option of an inner galvanised skin. The casing incorporates an internal burner profile opening (where applicable), and mild steel angle supports.

The unit is fitted with hinged access panel doors in the side of the heater for internal inspection of the fan, motor and burner module.

The heater air fan, motor and drive belts are fitted inside the heater casing on the downstream side of the burner and incorporate anti-vibration mounts.

Control system

The control of the heater is carried out by the dictates of the building management system or approved controls, specified in the wiring diagram.

Typical control sequences:

DF MUA control sequence

Outside occupancy times the space is protected by a frost set point. If the space temperature falls below the desired frost set point, the heater will start up and will operate at maximum discharge temperature to achieve a rapid heat up time. Once the space temperature rises above the frost set point the heater will shut down.

During occupancy times the space temperature is controlled to the occupied set point. If the space temperature is below the desired room set point, the heater will operate at maximum discharge temperature to achieve a rapid heat up time. As the space temperature approaches set point the discharge temperature set point will begin to reduce, this reduction in temperature will continue as long as the space temperature continues to rise until the minimum discharge set point temperature is reached. At 1°C above room set point the burner will shut down but the fan will continue to run, if space temperature falls below 0.5°C below set point the burner will restart and operate as described above.

Operation can be varied to suit site conditions.

DF VAV control sequence

Outside occupancy times the space is protected by a frost set point. If the space temperature falls below the desired frost set point, the heater will start up and will operate at maximum speed and at maximum discharge temperature to

1. Introduction cont.

achieve a rapid heat up time. Once the space temperature rises above the frost set point the heater will shut down.

During occupancy times the space temperature is controlled to the occupied set point. If the space temperature is below the desired room set point, the heater will operate at maximum speed and discharge temperature to achieve a rapid heat up time. As the temperature approaches 1°C below room set point the fan will begin to reduce in speed whilst discharging air at the maximum discharge set point temperature. The fan speed will continue to decrease as the space temperature rises until it has reached its minimum speed setting. As the space temperature approaches set point the discharge temperature will begin to reduce, this reduction in temperature will continue as long as the space temperature continues to rise until the minimum discharge set point temperature is reached. At 0.5°C above room set point the heater will shut down, if space temperature falls below 0.5°C below set point the heater will restart and operate as described above. If the space temperature increases to more than the room set point plus the customer set vent differential (adjustable 0-15°C) the fan only will start at low speed to bring fresh air into the room. This speed will gradually ramp up if the room temperature increases.

Operation can be varied to suit site conditions.

Control panel

The heater control panel incorporates a Satronic flame programmer, necessary MCBs, contactors, relays, indication lamps, illuminated push button etc. all pre-wired to a terminal rail.

Burner sequence

The purge, ignition and main flame stages of the burner are controlled via a Satronic approved flame programmer.

Overheat

In the event of an over-heat condition, within the heater casing, the heater is fitted with over temperature protection, which has to be manually reset if activated. Indication may be given by an amber lamp on the control panel. (See wiring diagram)

Safety interlocks

The DF heater includes the following safety interlocks:

1. Low air differential pressure switch.
2. Overheat controller.
3. Lockout on flame failure/or air pressure failure.

Site wiring

Site wiring requires the connection of:

1. 415v TPN + E or 230v 1PN + E 50Hz supply to the main heater control panel (refer to wiring diagram)
2. Data cable between heaters, where applicable.
3. Duct sensor, room sensor and outside air sensor.
4. External interlocks where applicable.

Fuel supply system

1: Start gas supply line (if applicable)

The start gas line comprises :

- a. Inlet gas isolating valve.
- b. Gas governor.
- c. Class A approved solenoid valves.
- d. Gas isolating valves.
- e. Pipework, fittings and pressure test points.

2: Main gas train

The main gas train comprises

- a. Inlet gas isolating valve.
- b. Combined gas governor, safety shut off valves and strainer.
- c. Motorised control ball valve.
- d. Burner isolating valve.
- e. Pipework, fittings and pressure test points.

2. General Requirements.

Related documents

The installation of the Econoair direct gas fired air heater must be in accordance with the relevant provisions of the Gas Safety (installations and use) Regulations 1998. Due account should also be taken of any obligations arising from the Health and Safety at Work act 1974, building regulations, and the current edition of the IEE wiring regulations.

It should also be in accordance with any relevant requirements of the local gas supplier, the local authority, the current IGEM technical standards and the relevant recommendations of

the following documents:

British standards

BS EN 525:1998

Non-domestic direct gas fired forced convection air heaters for space heating not exceeding a net heat input of 300 kW.

BS6230:2005

Specification for installation of gas fired forced convection air heaters for commercial and industrial space heating (2nd and 3rd family gases).

3. Ventilation Requirements.

Guidance for limitations of application of direct fired air heaters in buildings.

The examples given below are for achieving a MAC limit value of 5000×10^{-6} CO₂, reference gas G20. In the case of other limit values to suit national MAC levels and different gas categories, extrapolation is necessary.

General requirements.

Where vapour and/or gases or airborne dusts are present which degrade to products that are potentially harmful to health when passed through the combustion zone of a flame, all the air to a direct fired air heater shall be outside air. Recirculation, if practised shall be downstream of the burner combustion zone.

Safe operating emission levels.

The total installation, that is the combination of heater or heaters and ventilation facilities of the space or spaces to be supplied with the heated air, shall be designed and operated such that concentrations of carbon dioxide at positions where the air is likely to be inhaled by persons present shall not exceed 0.28% (V/V) (2800×10^{-6}). This level may differ, depending on local requirements.

Assessment of concentrations.

The specified maximum concentration of carbon dioxide can be assessed from the table below:

Designation of gas	G 20	G 25	G 31
V air required to limit CO ₂ concentration (0.28% m ³)	37.80	36.34	46.30

NOTE: The above assumes fresh air contains 0.03% CO₂

The following simplified equation is used to calculate the heat requirement, *H*, (in mJ/h) of the incoming air:

$$H = A \times V \times C_v \times T \times 10^{-3}$$

Where:

- A is the number of air changes per hour.
- V is the room volume in cubic metres.
- C_v is the heat capacity, volume basis, of air.*
- T is the temperature difference in kelvins.

* The specific heat of air as (1207 kJ/m³K)

4. Technical Data (Natural Gas G20 & G25).

MODEL RANGE	STD BURNER	VAV BURNER	BTU/Hr	BURNER REF	FAN SIZE	GROSS HEAT INPUT kW	NET HEAT INPUT kW	HEAT OUTPUT kW	GAS RATE m ³ / Hr
DF1	DF1MUA30	DF1VAV30	100000	6	180	29.31	26.40	26.40	2.82
DF2	DF2MUA50	DF2VAV50	200000	6	250	58.62	52.81	52.81	5.64
	DF2MUA75	DF2VAV75	250000	6	250	73.27	66.01	66.01	7.05
DF3	DF3MUA50	DF3VAV50	200000	6	355	58.62	52.81	52.81	5.64
	DF3MUA75	DF3VAV75	250000	6	355	73.27	66.01	66.01	7.05
	DF3MUA150	DF3VAV150	500000	12	355	146.54	132.02	132.02	14.09
DF4	DF4MUA75	DF4VAV75	250000	6	400	73.27	66.01	66.01	7.05
	DF4MUA100	DF4VAV100	350000	12	400	102.58	92.41	92.41	9.86
	DF4MUA150	DF4VAV150	500000	12	400	146.54	132.02	132.02	14.09
	DF4MUA220	DF4VAV220	750000	18	400	219.81	198.02	198.02	21.14
DF5	DF5MUA150	DF5VAV150	500000	12	500	146.54	132.02	132.02	14.09
	DF5MUA220	DF5VAV220	750000	18	500	219.81	198.03	198.03	21.14
	DF5MUA300	DF5VAV300	1000000	24	500	293.08	264.04	264.04	28.18
DF7	DF7MUA220	DF7VAV220	750000	18	560	219.81	198.03	198.03	21.14
	DF7MUA300	DF7VAV300	1000000	24	560	293.08	264.04	264.04	28.18
	DF7MUA375	DF7VAV375	1250000	30	560	366.35	330.05	330.05	35.23
DF9	DF9MUA300	DF9VAV300	1000000	24	630	293.08	264.04	264.04	28.18
	DF9MUA450	DF9VAV450	1500000	36	630	439.62	396.06	396.06	42.27
	DF9MUA500	DF9VAV500	1750000	42	630	512.90	462.07	462.07	49.32
DF11	DF11MUA300	DF11VAV300	1000000	24	710	293.08	264.04	264.04	28.18
	DF11MUA375	DF11VAV375	1250000	30	710	366.35	330.05	330.05	35.23
	DF11MUA500	DF11VAV500	1750000	42	710	512.90	462.07	462.07	49.32
	DF11MUA650	DF11VAV650	2250000	54	710	659.44	594.09	594.09	63.41
DF14	DF14MUA450	DF14VAV450	1500000	36	800	439.62	396.06	396.06	42.27
	DF14MUA600	DF14VAV600	2000000	48	800	586.17	528.08	528.08	56.36
	DF14MUA650	DF14VAV650	2250000	54	800	659.44	594.09	594.09	63.41
	DF14MUA725	DF14VAV725	2500000	60	800	732.71	660.10	660.10	70.45
	DF14MUA800	DF14VAV800	2750000	66	800	805.98	726.11	726.11	77.50
DF18	DF18MUA600	DF18VAV600	2000000	48	900	586.17	528.08	528.08	56.36
	DF18MUA800	DF18VAV800	2750000	66	900	805.98	726.11	726.11	77.50
	DF18MUA875	DF18VAV875	3000000	72	900	879.25	792.12	792.12	84.54
	DF18MUA1000	DF18VAV1000	3500000	84	900	1025.79	924.14	924.14	98.63
DF25	DF25MUA650	DF25VAV650	2250000	54	1000	659.44	594.09	594.09	63.41
	DF25MUA725	DF25VAV725	2500000	60	1000	732.71	660.10	660.10	70.45
	DF25MUA800	DF25VAV800	2750000	66	1000	805.98	726.11	726.11	77.50
	DF25MUA875	DF25VAV875	3000000	72	1000	879.25	792.12	792.12	84.54
	DF25MUA1000	DF25VAV1000	3500000	84	1000	1025.79	924.14	924.14	98.63
	DF25MUA1175	DF25VAV1175	4000000	96	1000	1172.33	1056.16	1056.16	112.72

4. Technical Data (Natural Gas G20 & G25) cont.

MODEL RANGE	STD BURNER	VAV BURNER	GAS INLET CONNECTION BSP	INLET GAS PRESSURE (mbar)	G20 NG 2 STD BURNER DIFF PRESSURE (mbar)	G20 NG 1 VAV BURNER DIFF PRESSURE (mbar)	G25 NG 2 STD BURNER DIFF PRESSURE (mbar)	G25 NG 1 VAV BURNER DIFF PRESSURE (mbar)	MINIMUM AIR RATE m ³ /sec	MAXIMUM AIR RATE m ³ /sec
DF1	DF1MUA30	DF1VAV30	½"	17	1.0	1.9	1.5	2.8	0.51	0.86
DF2	DF2MUA50	DF2VAV50	½"	17	3.8	7.5	5.5	10.9	1.03	1.72
	DF2MUA75	DF2VAV75	½"	17	6.0	11.7	8.7	17.0	1.28	2.16
DF3	DF3MUA50	DF3VAV50	½"	17	3.8	7.5	5.5	10.9	1.54	1.72
	DF3MUA75	DF3VAV75	½"	17	6.0	11.7	8.7	17.0	1.80	2.16
	DF3MUA150	DF3VAV150	¾"	17	6.0	11.7	8.7	17.0	2.57	3.08
DF4	DF4MUA75	DF4VAV75	½"	17	6.0	11.7	8.7	17.0	2.16	2.51
	DF4MUA100	DF4VAV100	¾"	17	2.9	5.7	4.2	8.3	2.52	3.02
	DF4MUA150	DF4VAV150	¾"	17	6.0	11.7	8.7	17.0	2.57	3.85
	DF4MUA220	DF4VAV220	1"	17	6.0	11.7	8.7	17.0	3.85	4.37
DF5	DF5MUA150	DF5VAV150	¾"	17	6.0	11.7	8.7	17.0	4.07	4.31
	DF5MUA220	DF5VAV220	1"	17	6.0	11.7	8.7	17.0	4.09	4.31
	DF5MUA300	DF5VAV300	1¼"	17	6.0	11.7	8.7	17.0	5.13	5.13
DF7	DF7MUA220	DF7VAV220	1"	17	6.0	11.7	8.7	17.0	5.05	5.39
	DF7MUA300	DF7VAV300	1¼"	17	6.0	11.7	8.7	17.0	5.13	5.99
	DF7MUA375	DF7VAV375	1½"	17	6.0	11.7	8.7	17.0	6.42	7.09
DF9	DF9MUA300	DF9VAV300	1¼"	17	6.0	11.7	8.7	17.0	7.07	7.70
	DF9MUA450	DF9VAV450	1½"	17	6.0	11.7	8.7	17.0	7.70	8.08
	DF9MUA500	DF9VAV500	1½"	17	6.0	11.7	8.7	17.0	8.98	9.09
DF11	DF11MUA300	DF11VAV300	1¼"	17	6.0	11.7	8.7	17.0	8.62	8.62
	DF11MUA375	DF11VAV375	1½"	17	6.0	11.7	8.7	17.0	8.98	10.78
	DF11MUA500	DF11VAV500	1½"	17	6.0	11.7	8.7	17.0	8.98	11.43
	DF11MUA650	DF11VAV650	2"	17	6.0	11.7	8.7	17.0	11.55	11.55
DF14	DF14MUA450	DF14VAV450	1½"	17	6.0	11.7	8.7	17.0	10.11	12.93
	DF14MUA600	DF14VAV600	2"	17	6.0	11.7	8.7	17.0	10.27	13.07
	DF14MUA650	DF14VAV650	2"	17	6.0	11.7	8.7	17.0	11.55	12.44
	DF14MUA725	DF14VAV725	2"	17	6.0	11.7	8.7	17.0	12.83	13.47
	DF14MUA800	DF14VAV800	2"	17	6.0	11.7	8.7	17.0	14.12	14.12
DF18	DF18MUA600	DF18VAV600	2"	17	6.0	11.7	8.7	17.0	13.47	14.14
	DF18MUA800	DF18VAV800	2"	17	6.0	11.7	8.7	17.0	14.12	15.60
	DF18MUA875	DF18VAV875	2"	17	6.0	11.7	8.7	17.0	15.40	17.02
	DF18MUA1000	DF18VAV1000	2"	17	6.0	11.7	8.7	17.0	17.96	18.18
DF25	DF25MUA650	DF25VAV650	2"	17	6.0	11.7	8.7	17.0	17.96	19.40
	DF25MUA725	DF25VAV725	2"	17	6.0	11.7	8.7	17.0	18.91	20.73
	DF25MUA800	DF25VAV800	2"	17	6.0	11.7	8.7	17.0	20.44	21.96
	DF25MUA875	DF25VAV875	2"	17	6.0	11.7	8.7	17.0	20.86	23.95
	DF25MUA1000	DF25VAV1000	2"	17	6.0	11.7	8.7	17.0	20.96	24.34
	DF25MUA1175	DF25VAV1175	2"	17	6.0	11.7	8.7	17.0	20.53	26.13

4. Technical Data (Propane G31).

MODEL RANGE	STD BURNER	VAV BURNER	BTU/Hr	BURNER REF	FAN SIZE	GROSS HEAT INPUT kW	NET HEAT INPUT kW	HEAT OUTPUT kW	GAS RATE kg/ Hr
DF1	DF1MUA30	DF1VAV30	100000	6	180	29.31	26.89	26.89	2.09
DF2	DF2MUA50	DF2VAV50	200000	6	250	58.62	53.78	53.78	4.19
	DF2MUA75	DF2VAV75	250000	6	250	73.27	67.22	67.22	5.23
DF3	DF3MUA50	DF3VAV50	200000	6	355	58.62	53.78	53.78	4.19
	DF3MUA75	DF3VAV75	250000	6	355	73.27	67.22	67.22	5.23
	DF3MUA150	DF3VAV150	500000	12	355	146.54	134.44	134.44	10.47
DF4	DF4MUA75	DF4VAV75	250000	6	400	73.27	67.22	67.22	5.23
	DF4MUA100	DF4VAV100	350000	12	400	102.58	94.11	94.11	7.33
	DF4MUA150	DF4VAV150	500000	12	400	146.54	134.44	134.44	10.47
	DF4MUA220	DF4VAV220	750000	18	400	219.81	201.66	201.66	15.70
DF5	DF5MUA150	DF5VAV150	500000	12	500	146.54	134.44	134.44	10.47
	DF5MUA220	DF5VAV220	750000	18	500	219.81	201.66	201.66	15.70
	DF5MUA300	DF5VAV300	1000000	24	500	293.08	268.88	268.88	20.93
DF7	DF7MUA220	DF7VAV220	750000	18	560	219.81	201.66	201.66	15.70
	DF7MUA300	DF7VAV300	1000000	24	560	293.08	268.88	268.88	20.93
	DF7MUA375	DF7VAV375	1250000	30	560	366.35	336.10	336.10	26.17
DF9	DF9MUA300	DF9VAV300	1000000	24	630	293.08	268.88	268.88	20.93
	DF9MUA450	DF9VAV450	1500000	36	630	439.62	403.33	403.33	31.40
	DF9MUA500	DF9VAV500	1750000	42	630	512.90	470.55	470.55	36.64
DF11	DF11MUA300	DF11VAV300	1000000	24	710	293.08	268.88	268.88	20.93
	DF11MUA375	DF11VAV375	1250000	30	710	366.35	336.10	336.10	26.17
	DF11MUA500	DF11VAV500	1750000	42	710	512.90	470.55	470.55	36.64
	DF11MUA650	DF11VAV650	2250000	54	710	659.44	604.99	604.99	47.10
DF14	DF14MUA450	DF14VAV450	1500000	36	800	439.62	403.33	403.33	31.40
	DF14MUA600	DF14VAV600	2000000	48	800	586.17	537.77	537.77	41.87
	DF14MUA650	DF14VAV650	2250000	54	800	659.44	604.99	604.99	47.10
	DF14MUA725	DF14VAV725	2500000	60	800	732.71	672.21	672.21	52.34
	DF14MUA800	DF14VAV800	2750000	66	800	805.98	739.43	739.43	57.57
DF18	DF18MUA600	DF18VAV600	2000000	48	900	586.17	537.77	537.77	41.87
	DF18MUA800	DF18VAV800	2750000	66	900	805.98	739.43	739.43	57.57
	DF18MUA875	DF18VAV875	3000000	72	900	879.25	806.65	806.65	62.80
	DF18MUA1000	DF18VAV1000	3500000	84	900	1025.79	941.09	941.09	73.27
DF25	DF25MUA650	DF25VAV650	2250000	54	1000	659.44	604.99	604.99	47.10
	DF25MUA725	DF25VAV725	2500000	60	1000	732.71	672.21	672.21	52.34
	DF25MUA800	DF25VAV800	2750000	66	1000	805.98	739.43	739.43	57.57
	DF25MUA875	DF25VAV875	3000000	72	1000	879.25	806.65	806.65	62.80
	DF25MUA1000	DF25VAV1000	3500000	84	1000	1025.79	941.09	941.09	73.27
	DF25MUA1175	DF25VAV1175	4000000	96	1000	1172.33	1075.53	1075.53	83.74

4. Technical Data (Propane G31) cont.

MODEL RANGE	STD BURNER	VAV BURNER	GAS INLET CONNEC-TION BSP	INLET GAS PRESSURE (mbar)	NG 2 STD BURNER DIFF PRESSURE (mbar)	NG 1 VAV BURNER DIFF PRESSURE (mbar)	MINIMUM AIR RATE m ³ /sec	MAXIMUM AIR RATE m ³ /sec
DF1	DF1MUA30	DF1VAV30	½"	37	0.5	1.0	0.52	0.88
DF2	DF2MUA50	DF2VAV50	½"	37	1.5	2.9	1.05	1.76
	DF2MUA75	DF2VAV75	½"	37	2.5	4.9	1.31	2.20
DF3	DF3MUA50	DF3VAV50	½"	37	1.5	2.9	1.05	1.76
	DF3MUA75	DF3VAV75	½"	37	2.5	4.9	1.31	2.20
	DF3MUA150	DF3VAV150	½"	37	2.5	4.9	2.61	3.14
DF4	DF4MUA75	DF4VAV75	½"	37	2.5	4.9	1.31	2.55
	DF4MUA100	DF4VAV100	½"	37	1.5	2.9	1.83	3.07
	DF4MUA150	DF4VAV150	½"	37	2.5	4.9	2.61	3.92
	DF4MUA220	DF4VAV220	¾"	37	2.5	4.9	3.92	4.45
DF5	DF5MUA150	DF5VAV150	½"	37	2.5	4.9	2.61	4.39
	DF5MUA220	DF5VAV220	¾"	37	2.5	4.9	3.92	4.39
	DF5MUA300	DF5VAV300	¾"	37	2.5	4.9	5.23	5.23
DF7	DF7MUA220	DF7VAV220	¾"	37	2.5	4.9	3.92	5.49
	DF7MUA300	DF7VAV300	¾"	37	2.5	4.9	5.23	6.10
	DF7MUA375	DF7VAV375	¾"	37	2.5	4.9	6.53	7.22
DF9	DF9MUA300	DF9VAV300	¾"	37	2.5	4.9	5.23	7.84
	DF9MUA450	DF9VAV450	¾"	37	2.5	4.9	7.84	8.23
	DF9MUA500	DF9VAV500	¾"	37	2.5	4.9	9.15	9.26
DF11	DF11MUA300	DF11VAV300	¾"	37	2.5	4.9	5.23	8.78
	DF11MUA375	DF11VAV375	¾"	37	2.5	4.9	6.53	10.98
	DF11MUA500	DF11VAV500	¾"	37	2.5	4.9	9.15	11.64
	DF11MUA650	DF11VAV650	1"	37	2.5	4.9	11.76	11.76
DF14	DF14MUA450	DF14VAV450	¾"	37	2.5	4.9	7.84	13.17
	DF14MUA600	DF14VAV600	¾"	37	2.5	4.9	10.45	13.31
	DF14MUA650	DF14VAV650	1"	37	2.5	4.9	11.76	12.67
	DF14MUA725	DF14VAV725	1"	37	2.5	4.9	13.07	13.72
	DF14MUA800	DF14VAV800	1½"	37	2.5	4.9	14.37	14.37
DF18	DF18MUA600	DF18VAV600	¾"	37	2.5	4.9	10.45	14.40
	DF18MUA800	DF18VAV800	1½"	37	2.5	4.9	14.37	15.89
	DF18MUA875	DF18VAV875	1½"	37	2.5	4.9	15.68	17.33
	DF18MUA1000	DF18VAV1000	1½"	37	2.5	4.9	18.29	18.52
DF25	DF25MUA650	DF25VAV650	1"	37	2.5	4.9	11.76	19.76
	DF25MUA725	DF25VAV725	1"	37	2.5	4.9	13.07	21.11
	DF25MUA800	DF25VAV800	1½"	37	2.5	4.9	14.37	22.36
	DF25MUA875	DF25VAV875	1½"	37	2.5	4.9	15.68	23.52
	DF25MUA1000	DF25VAV1000	1½"	37	2.5	4.9	18.29	24.79
	DF25MUA1175	DF25VAV1175	1½"	37	2.5	4.9	20.91	26.61

4. Technical Data cont.

Options

- Available in horizontal or vertical orientation denoted by H or V.
- Available as internal as standard or with weather kit for external use denoted by EX.
- Available with options such as filters (bag, panel) and silencers.
- Available with different motors to suit a range of ESPs from 50 to 1000 Pa.
- Available without a fan as a duct package denoted by DP after the range number such as DF5DPVAV150.
- Available without a fan and with a frame for fitting inside customers AHU denoted by AH after the range number such as DF5AH150.
- The maximum temperature rise through the unit is 42°C based on minimum air rate.

Diagram 1: Clearances required for maintenance
(Generic heater shown for illustration purposes)

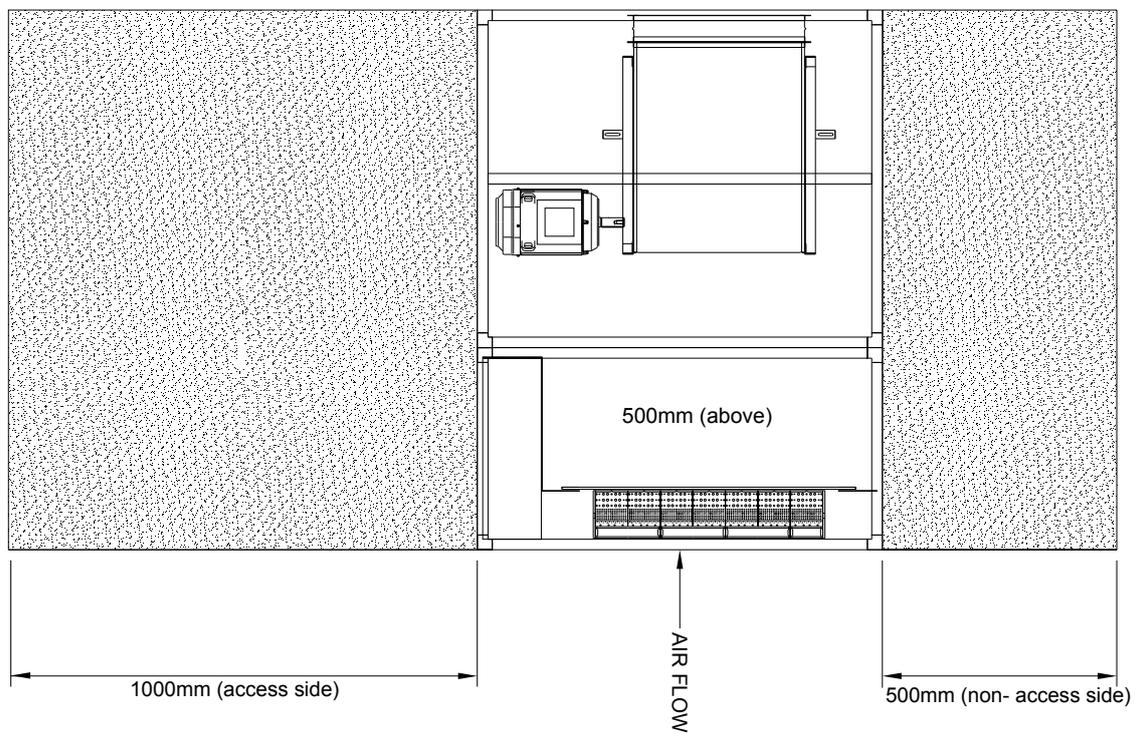

4. Technical Data cont.

Diagram 2: Horizontal units (VAV model shown) See diagrams 6 and 7 for burner details.

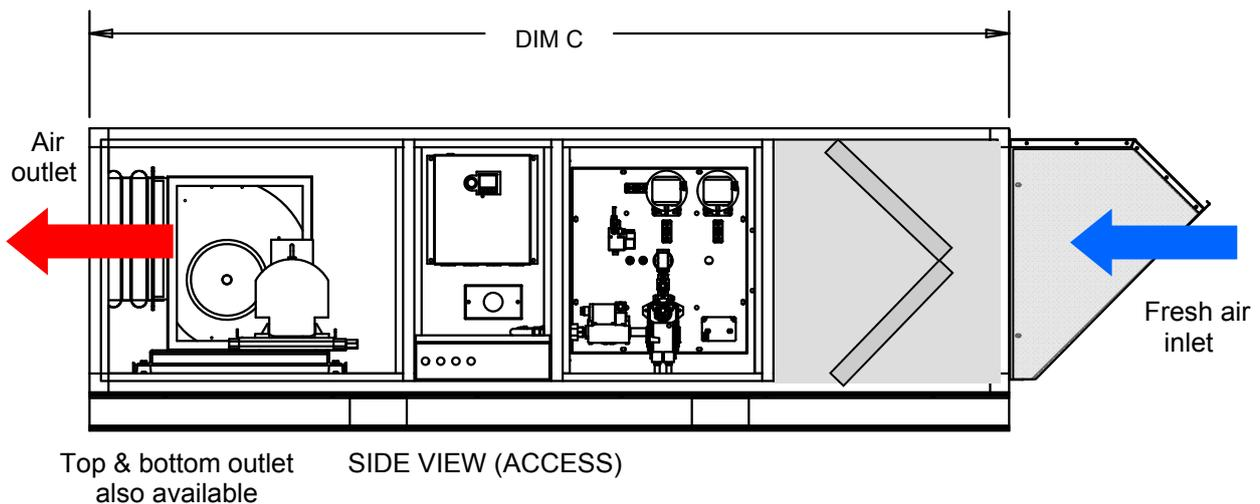
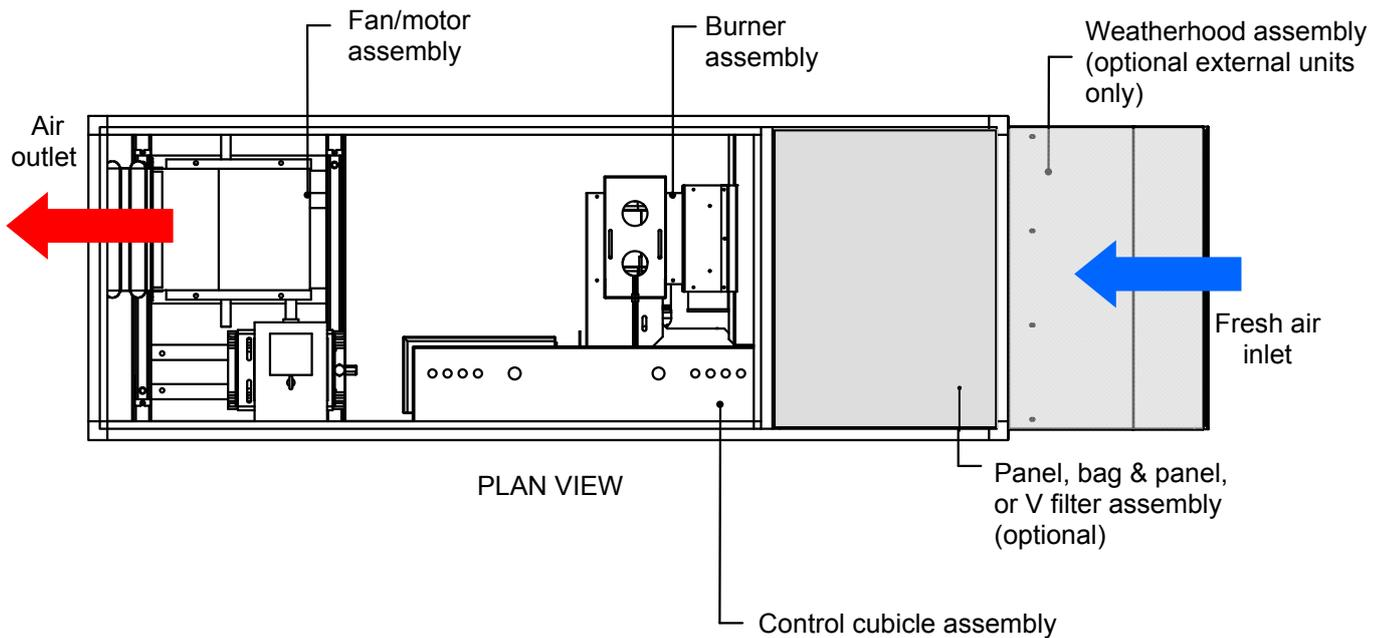
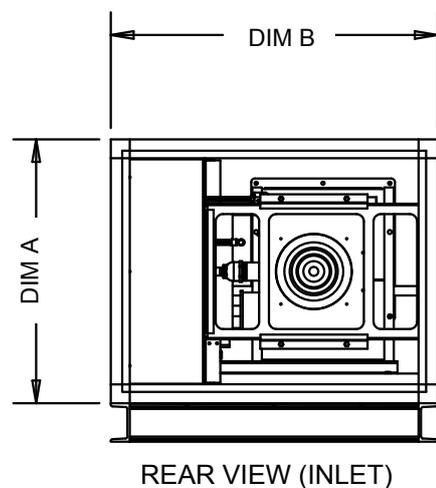

Table1:Horizontal unit dimensions

Model Range	A	B	C	
			No filter	Panel+ V filter
DF1/2	700	860	1800	2420
DF3	1000	1100	2000	2640
DF4	1250	1250	2600	3240
DF5/7	1650	1500	2900	3540
DF9/11	1900	2000	3200	3840
DF14	2200	2200	3500	4140
DF18/25	2350	2600	3500	4140



Horizontal units are denoted the letter 'H' inserted after the model No. such as: DF5VAV150H. If the unit is also for external use, (with optional weatherkit) the letters 'EX' should be included at the end of the model No. such as: DF5VAV150HEX.

4. Technical Data cont.

Diagram 3: Vertical units (VAV model shown)
See diagrams 6 and 7 for burner details

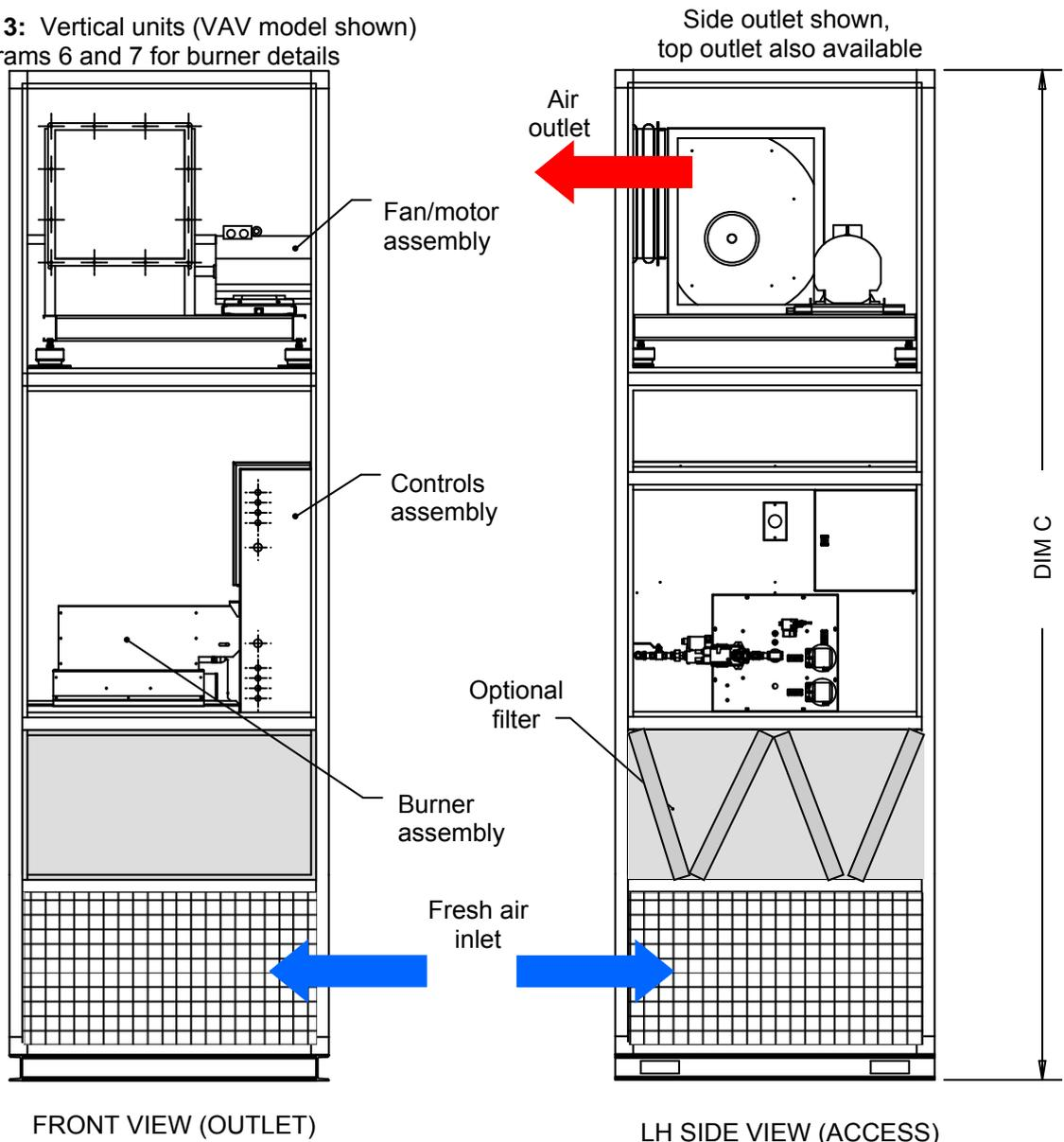
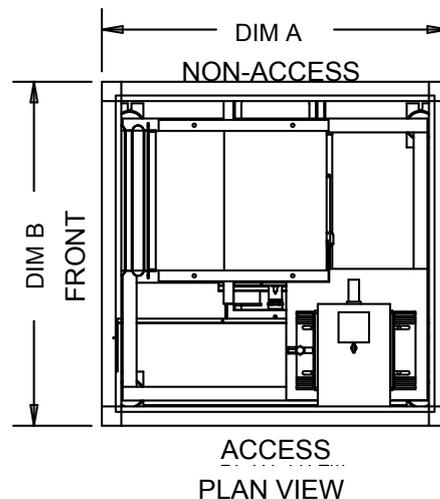

Table2: Vertical unit dimensions

Model Range	A	B	C	
			With filters	No filter
DF1/2	700	860	3142	2522
DF3	1000	1100	3382	2742
DF4	1250	1250	3982	3342
DF5/7	1650	1500	4332	3692
DF9/11	1900	2000	4632	3992
DF14	2200	2200	4972	4312
DF18/25	2350	2600	4972	4312



Vertical units are denoted the letter 'V' inserted after the model No. such as: DF5VAV150V.

4. Technical Data cont.

Diagram 4: DP units (VAV model shown) See diagrams 6 and 7 for burner details

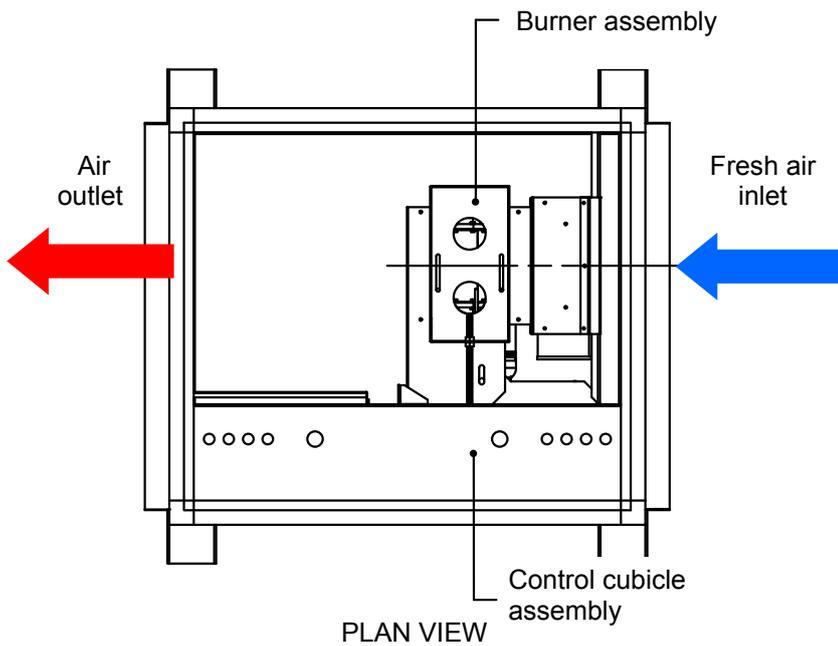
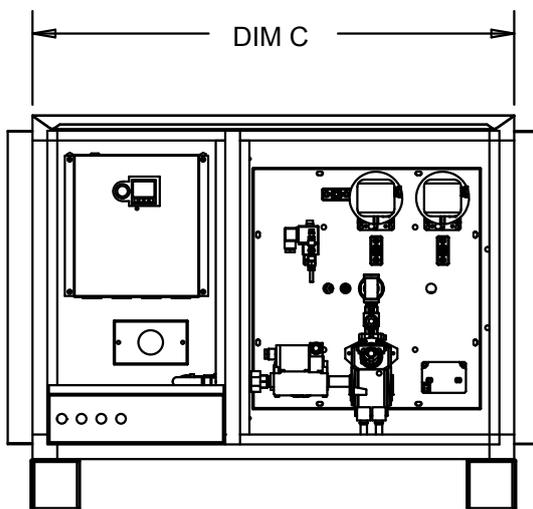
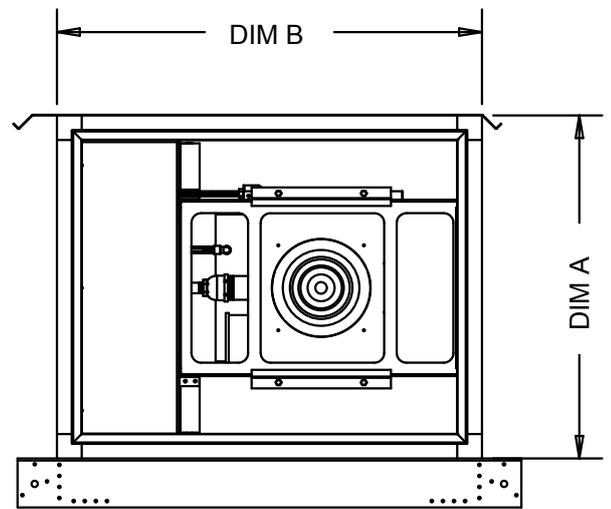

Table3: DP unit dimensions

Model Range	A	B	C
DF1/2	700	860	975
DF3	1000	1100	1095
DF4	1250	1250	1015
DF5/7	1650	1500	1045
DF9/11	1900	2000	1045
DF14	2200	2200	1045
DF18/25	2350	2600	1060



SIDE VIEW (ACCESS)



REAR VIEW (INLET)

These units are supplied without a fan as a duct package denoted by DP inserted after the range No. such as: DF5DPVAV150.

Refer to section 5 (Installation Details) for descriptions of burner types.

Note: See section 6 (Commissioning and Testing) for combustion settings.

4. Technical Data cont.

Diagram 5: AH units (VAV model shown) See diagrams 6 and 7 for burner details

Table3: AH units dimensions

Model Range	Overall dimensions			Cabinet depth	Client case width	Client case length	Burner inlet gap	Burner outlet gap
	A	B	C					
DF1	640	500	765	350	925	1600	200	1000
DF2/3	640	500	765	350	925	1600	200	1000
DF2/3/4	640	500	765	350	925	1600	200	1000
DF4	840	575	900	350	1045	1600	200	1000
DF3/4/5	840	575	900	350	1045	1600	200	1000
DF4/5/7	1000	790	1000	350	1320	1800	200	1200
DF5/7/9/11	1000	960	1000	350	1560	1800	200	1200
DF7/11	1000	1110	1000	350	1710	1800	200	1200
DF9/14	1000	1255	1000	350	1865	1800	200	1200
DF9/11	1200	1420	1000	350	2020	1800	200	1200
DF14/18	1200	1210	1000	350	1810	1800	200	1200
DF11/14	1200	1360	1000	350	1960	1800	200	1200
DF14/25	1200	1510	1000	350	2110	1800	200	1200
DF14/18/25	1200	1650	1000	350	2250	1800	200	1200
DF18/25	1200	1810	1000	350	2410	1800	200	1200

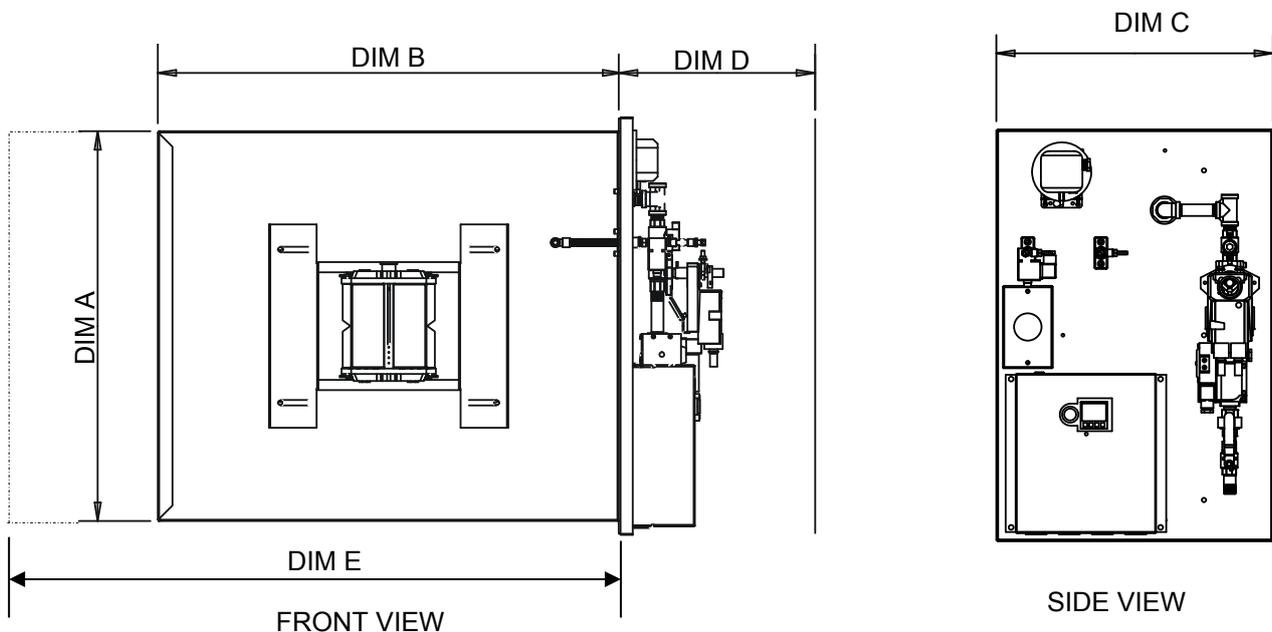
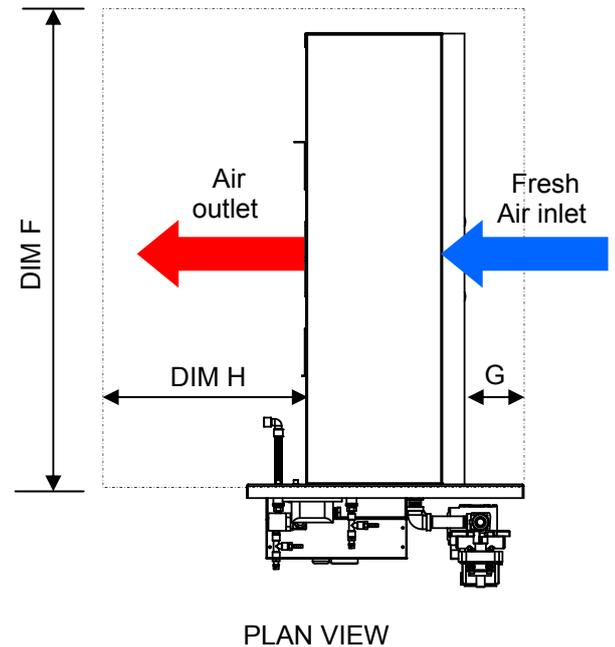

These units are supplied without a fan and including a frame for fitting inside customers AHU denoted by AH inserted after the range No. such as: DF5AH150.

Refer to section 5 (Installation Details) for descriptions of burner types.

Note: See section 6 (Commissioning and Testing) for combustion settings.

4. Technical Data cont.

Process diagram: DF MUA heater.

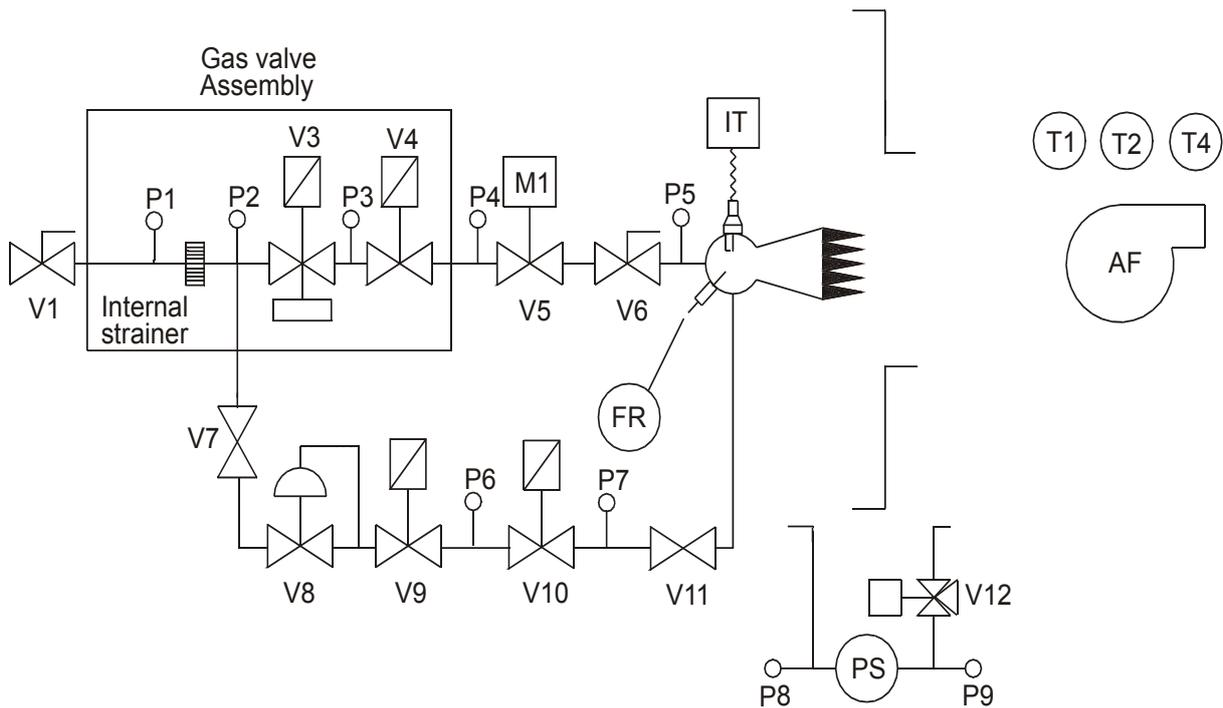

Valve and instrument list.

V1	Main gas isolating valve	AF	Air fan
V3/V4	Combination main safety shut off valves with integral governor	FR	Flame rod
V5	Motorised ball valve	IT	Ignition transformer
V6	Burner isolating valve	M1	Modulating control valve motor
V7	Pilot gas isolating valve	P4	Air pressure switch
V8	Pilot governor	T1	Room sensor
V9/V10	Pilot solenoid valves	T2	Duct sensor
V11	Pilot isolating valve	T3	Outside air sensor (optional, see wiring diagram))
V12	3 way solenoid valve (optional)	T4	Overheat device
		P1 to P9	Pressure test points

4. Technical Data cont.

Process diagram: DF VAV heater

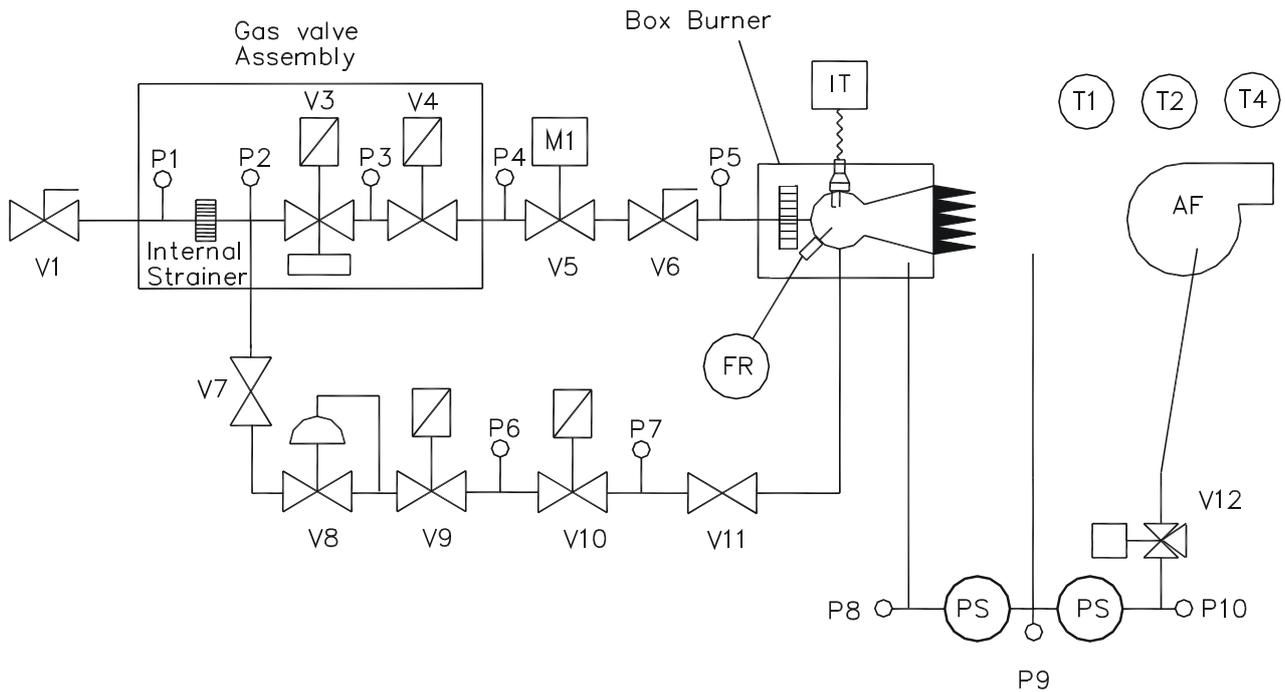

Valve and instrument list.

V1	Main gas isolating valve	AF	Air fan
V3/V4	Combination main safety shut off valves with integral governor	FR	Flame rod
V5	Motorised ball valve	IT	Ignition transformer
V6	Burner isolating valve	M1	Modulating control valve motor
V7	Pilot gas isolating valve	P4	Air pressure switch
V8	Pilot governor	T1	Room sensor
V9/V10	Pilot solenoid valves	T2	Duct sensor
V11	Pilot isolating valve	T3	Outside air sensor (optional, see wiring diagram)
V12	3 way solenoid valve (optional)	T4	Overheat device
		P1 to P10	Pressure test points

4. Technical Data cont.

Burner types

Diagram 6: NG1 VAV burner

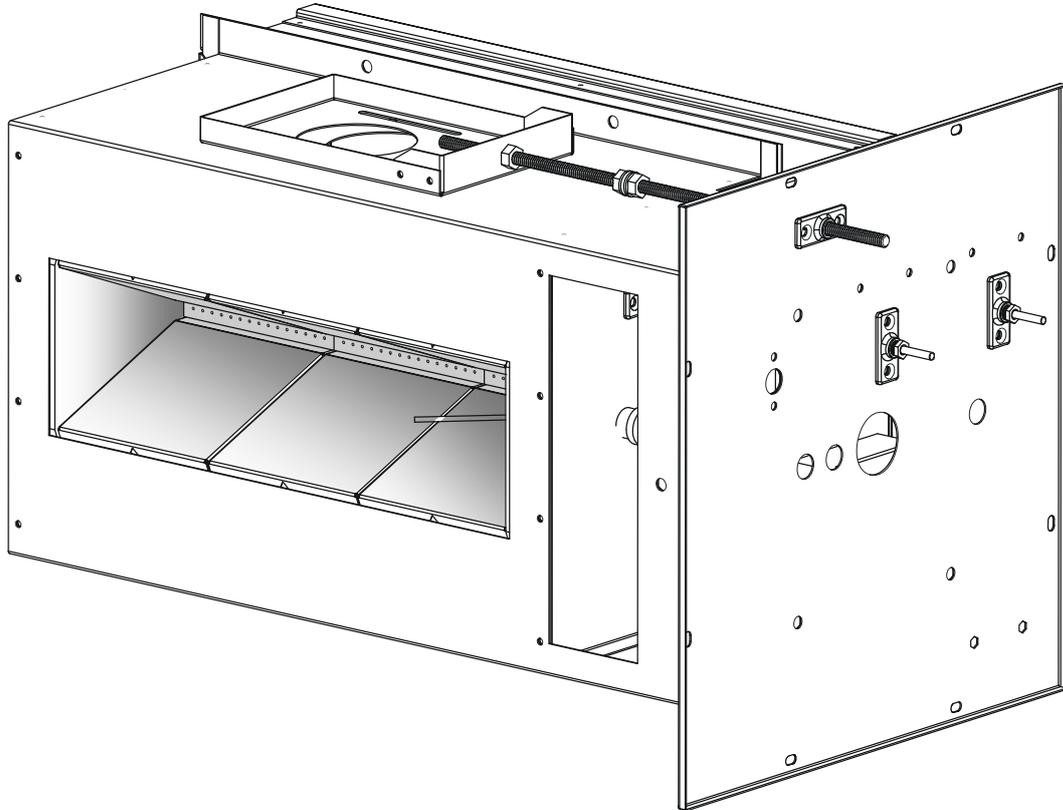
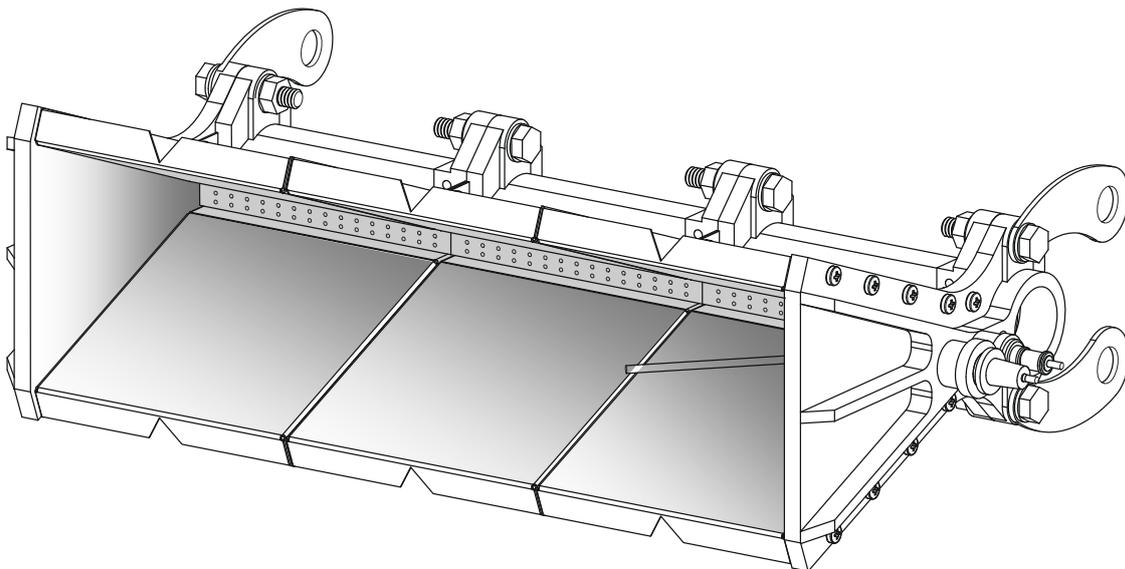

Diagram 7: NG2 standard burner



4. Technical Data cont.

Diagram 7: Typical MUA burner controls

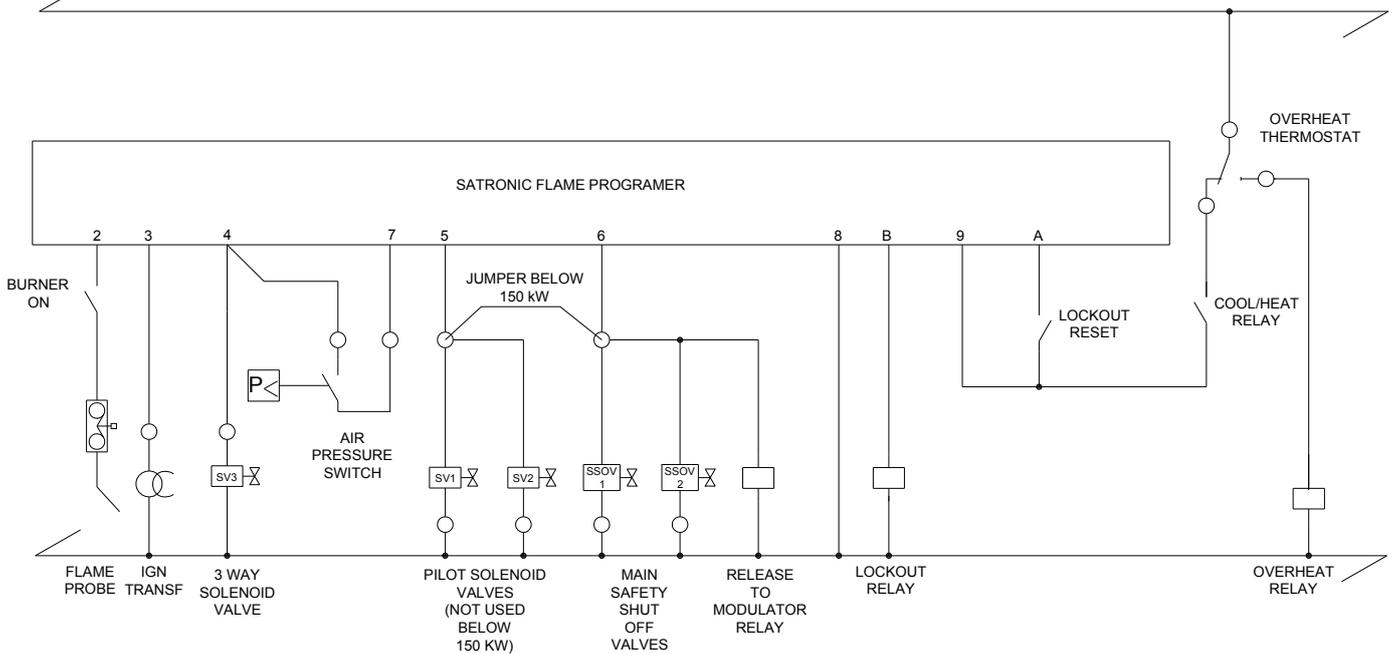
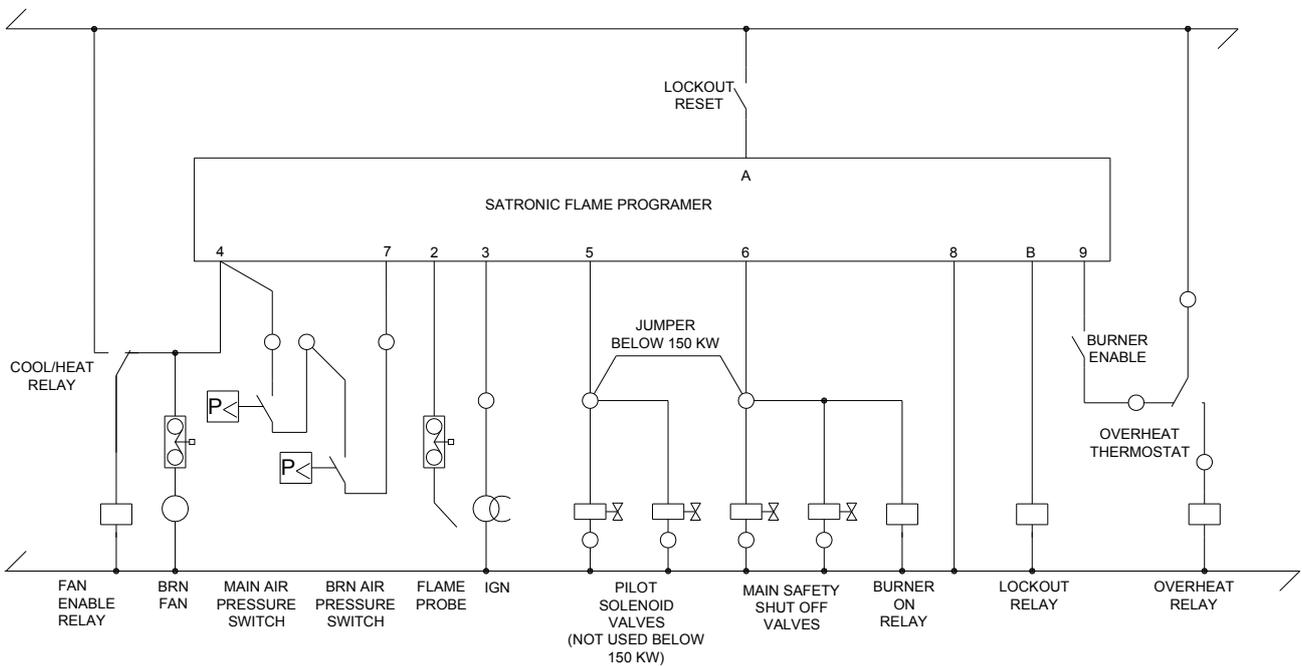

Diagram 8: Typical VAV burner controls



Note: For further information regarding wire numbers, BMS controls etc., please refer to the main control panel wiring diagram supplied with the heater. A copy of this diagram is available on request (quoting the serial number of your heater).

5. Installation Details.

Installation

MUA and VAV heaters

Note: Only a suitably qualified, competent person should install this heater.

Before installation check that the local distribution conditions, nature of gas and pressure, and the current state of the adjustment of the appliance are compatible.

It will be necessary for the installer to refer to the appliance data plate for information specific to the air flow rates and gas rates for the particular appliance being installed.

Vertical outdoor configuration

The heater should be positioned onto a flat level prepared concrete base, with a minimum size to suit the footprint of the heater, and allow a minimum 500mm clearance from the building to the front face of the heater, 1000mm clearance to the access side, which can be either the left or right hand side of the heater determined prior to manufacture, 500mm to the non access side, and rear of the heater, and 500mm above the heater. (See diagram 1 in the technical data section).

Depending on the case size, heaters can be supplied in a single section or multiple sections, namely the support stand, burner section and fan section, with rubber sealing strips pre-fitted to the mating faces. The support stand should be lifted into position ensuring that the removable bird mesh screen panel is situated on the access side of the heater, using a suitably sized fork lift truck through the channel lifting points incorporated in the base frame, or via a crane with the lifting straps threaded through the channel lifting points, and spreader bars between the straps at the top of the frame to prevent the straps from exerting any undue force onto the frame. The frame should be clamped to the concrete base on four corners. The burner section should be lifted onto the support stand, using a suitably sized fork lift truck, or crane, as previously described, ensuring that the control panel doors are situated on the access side.

The fan section should be lifted onto the burner section, using a fork lift truck or crane as previously described for positioning the base frame, ensuring that the fan access door is positioned on the heater access side, and the discharge spigot if side discharge is facing the building, and if top discharge the air off-take spigot should be furthest from the building. The fan and burner sections should be bolted together using the fixings provided.

Four cover plates are provided to blank off the forklift truck lifting points in each section using the M6 setscrews provided on completion of the installation.

The supply ductwork into the building should be

sized as per the flanged inlet to the distribution head. For heaters with the extended internal ductwork, the ductwork should be sized to ensure that the external static resistance does not exceed the figure specified on the data badge.

Horizontal outdoor configuration

The heater should be positioned onto a prepared flat level concrete base, or support steelwork frame to give a minimum 500mm clearance to the bottom edge of the air inlet of the heater from floor level, 500mm clearance on the non-access side, and 1000mm clearance on the access side.

Depending on the case size, heaters can be supplied in a single section or multiple sections.

The heaters should be fitted into position using a suitably sized fork lift truck through the lifting channels incorporated within the base frame, or via a crane, with lifting straps threaded through the lifting channels. To protect damage to the top of the heater casing, spreader bars must be used between the straps.

Ductwork criteria is identical to that stated for vertical outdoor configuration.

An air inlet weather cowl can be supplied as an optional item.

Note: careful consideration must be given to the location of the fresh air inlets in relationship to the prevailing winds, especially when installed at elevated levels. In site conditions where this is not possible the heater should be provided with specially designed inlet hoods to prevent the ingress of rain or snow.

Vertical indoor configuration

The heater should be positioned onto a prepared flat level concrete base, or support steelwork frame with a minimum 500mm clearance on the non-access sides, and 1000mm on the access sides (See diagram 1).

Depending on the case size, heaters can be supplied in a single section or multiple sections, namely the burner/base unit, and the fan section, with rubber sealing strips pre-fitted to the mating faces. The burner/base unit should be lifted into position using a suitably sized fork lift truck or crane as previously described, with the fresh air inlet opening facing the outside wall. The fan section should be lifted onto the burner section, with the fan discharge on side discharge units, on the opposite side to the fresh air inlet. The fan and burner sections should be bolted together using the fixings provided. Four cover plates are provided to blank off the forklift truck lifting points in each section using the M6 setscrews provided on completion of the installation.

The heater fresh air inlet is sized at 6m/s, the inlet ductwork should be increased to give 2.5m/s when using inlet weather louvres, cowls etc, to prevent water carryover into the heater.

18 The discharge ductwork should be sized as per

5. Installation Details cont.

the flanged connection on the distribution head. Any external ductwork should be sized to ensure that the static resistance does not exceed the figure stated on the data badge.

Horizontal indoor configuration

Depending on the case size, heaters can be supplied in a single section or multiple sections. It is usual for horizontal units to be mounted above floor level, due to the amount of floor space they would take up, and are normally positioned onto the roofs of internal offices/mezzanine areas or into the building steelwork.

For heaters being installed onto the roof of offices etc., the roof must be adequate to take the weight of the heater, and be adjacent to an outside wall, to allow fresh air to be ducted to the heater. A 1000mm clearance would be required on the access side of the heater, and a minimum 500mm clearance required on the non-access side and top of the heater.

For heaters mounted in the roof steel work, a steel support frame will be required incorporating a 1000mm access platform.

The fresh air to the heater should be ducted through the roof, with a fresh air inlet sized to achieve inlet velocities of 2.5m/sec. Supply ductwork should be sized to suit the flange connection on the distribution head, or for extended ductwork runs, sized to ensure that the external static resistance does not exceed that stated on the data badge.

The fan/burner section should be lifted into position with suitably sized fork lift truck, using the lifting channels incorporated within the base frame, or via a crane with lifting straps threaded through the lifting channels, with spreader bars positioned between the straps to prevent damage to the roof of the heater.

Connection of services

Gas supply

The Úđ \ cã ÁMUA and VAV heaters are designed for use with natural gas (G20 & G25) and propane (G31).

The gas type for this heater is marked on the appliance data badge. Check that the available gas supply is as marked and within the pressure range given in heater specification.

Service pipes

The local supplier of gas should be consulted at the installation planning stage in order to establish the availability of an adequate supply of gas. An existing service pipe must not be used without prior consultation with the local gas supplier.

Meters

A gas meter is connected to the service pipe by

the local supplier of gas or the local contractor. Any existing meter used should be checked, preferably by the local gas supplier, to ensure that the meter is adequate to deal with the rate of gas required by the heater.

Installation pipes

Installation pipes should be installed and tested in accordance with the current IGEM technical standards.

Note: If a long pipe run is needed to supply the heater, the line pressure drop should be calculated before installation and the supply pipework sized accordingly.

Gas pressure at the heater inlet under full fire conditions should be at least 17.0mbar. Gas pressure with main burner off must not exceed 100mbar.

Boosted supplies

Where it is necessary to employ a gas pressure booster, the controls must include a low pressure cut-off switch fitted upstream of the booster. This must shut down the booster in the event of reduced pressure and prevent automatic restart on pressure restoration. The cut-off pressure shall be decided by the local gas supplier.

The local gas supplier must be consulted before a gas pressure booster is fitted.

Guidance is given for low pressure cut-off switches in the current IGEM technical standards.

Where additional controls are used they should be CE approved items.

Electrical supply/controls

Wiring external to the heater must be installed in accordance with the current edition of the IEE Wiring Regulations, and any other local regulations in force.

StokvisDF units operate from either a 415v TPN + E, or 230v 1PN + E 50Hz supply, (refer to wiring diagram).

The method of connection to the main electricity supply must facilitate complete electrical isolation of the heater. The method of connection should be provided adjacent to each heater in a readily accessible position.

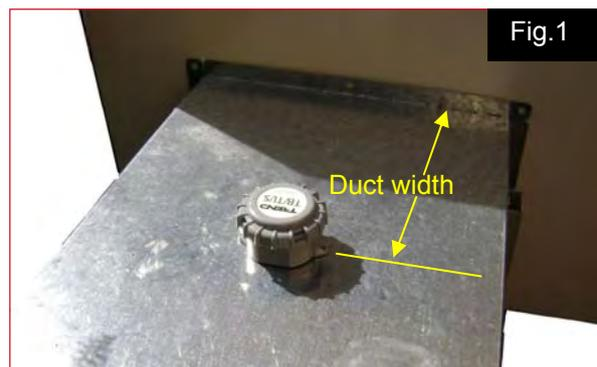

5. Installation Details cont.

Sensors should be wired with a twisted pair screened cable, Belden Ref 8762 or equivalent. Where a duct discharge sensor is not factory fitted it should be installed in the centre of the discharge ducting as shown in Fig.1. then wired back to the controller which is fitted either inside, or adjacent to, the main control panel. Please note that sensor type may vary from that shown in Fig.1

Mains supply cables are to be sized to suit the electrical rating of the heater as indicated on the data badge/ wiring diagram.

Control cable size should not be less than 0.75mm² CSA (refer to wiring diagram).

Note: The appliance and the ancillary controls must be correctly earthed.

Internal wiring

The amount of interconnecting wiring will depend on the control system being used, this will be indicated on the schematic wiring diagram supplied with the heater.

6. Commissioning & Testing.

Commissioning and testing

Econoair DF Heaters should only be commissioned by a suitably qualified and competent person.

The commissioning service does not cover responsibility for the connection of the gas and electrical services which remain the responsibility of the installer.

Commissioning sheets are available on request.

General installation

The installation should be checked to ensure that work carried out is in accordance with the design requirements.

Check that there is an adequate air supply.

Gas installation

The whole of the gas installation, including the meter, should be inspected and tested for soundness and purged in accordance with the recommendations of the current IGEM technical standards.

Electrical installation

Checks to ensure electrical safety should be carried out by a suitably qualified and competent person.

Commissioning procedure

To be read in conjunction with the schematic wiring diagram, and process diagram. Commissioning of Econoair heaters should be carried out by competent engineers, with knowledge of the BMS control sequences. Training courses are available.

All heaters require the following inspection to be carried out PRIOR TO commissioning.

All manual gas valves are closed.

All electrical supplies are isolated.

Electrical earth continuity between the heaters, gas pipework and main electrical supply.

Gas installation pipework has been tested for soundness.

Gas installation has been purged.

Note and record fan motor data badge details.

Note and record fan and motor pulley sizes, belt reference and pulley centres, fan belt tension and alignment.

Check overheat controller setting is 85°C.

Commissioning settings are to be recorded on a commissioning sheet, available on request.

Pre-firing commissioning

A laptop incorporating the control strategy, display device, or approved controller is to be connected to the heater.

Ensure all MCB's in control panel are in the OFF position.

Set motor overload to the motor plate FLC.

Set discharge head vertical distribution blades to give maximum spread, and the horizontal blades slightly upwards, to prevent downward air movement.

Discharge heads fitted with Novo-Jet nozzles should be twisted to give maximum spread with no downward air movement.

Switch on electrical supply to heater. Check voltage across each phase for 415 volts, and down to neutral for 240 Volts.

Switch on the 240 and 24 volt control circuit breakers power on lamp will energise.

Check the BMS out station for the heater address reference number.

Override the system and burner enable relays to off.

Switch fan motor circuit breakers to ON position.

Override system enable to ON position, air fan will start.

Check fan rotation is correct, if not, isolate electrical supply and change over two of the phases. Switch on electrical supply and re-check rotation.

Measure and record motor FLC on each phase.

Check and record air velocity over the profile plate. Reading should be between 14 -16m/sec.

On MUA versions an adjustable profile plate is incorporated and set at the optimum position and is marked by three centre punch marks in line with the corner of each profile plate. The optimum pressure differential is 1.25 mbar between pressure tapping points P8 and P9. Should the profile plate require adjustment, isolate heater electrical and gas supplies, access inside the unit, open or close plates, re-mark position and record opening size. Restart heater and check pressure between tapping points P8 and P9, air velocity and gas line suction at tapping points P5.

Check within the factory area that no air movement can be felt at low level. Adjust horizontal blades in distribution head or Novo-Jet nozzles if necessary.

On VAV heaters, measure and record motor current at high speed, measure and record suction at pressure point P5. Reduce to minimum speed, measure and record motor current, measure and record suction at pressure point P5.

Check gas soundness of the gas control train by leak testing.

Burner commissioning

To be read in conjunction with the schematic wiring diagram and the process diagram. Commissioning settings should be recorded on separate commissioning sheets, available on request.

Override system to ON (fan running).

6. Commissioning & Testing cont.

Override the burner to ON, flame programmer will commence a purge, followed by ignition sequence and lockout.

Open main gas isolating valve V1, and pilot isolating valves V7 and V11. Ensure burner isolating valve V6 is closed.

Connect a suitable manometer to pressure tapping point P7.

Depress the lockout-reset button on the front of the Satronic flame programmer, a purge will

need setting. Insert an allen key in the brass cap screw and turn anti-clockwise $\frac{1}{2}$ turn as shown in Fig. 2. Adjust start gas rate (Ps on valve) as shown in Fig.3. Set to 33% of the maximum gas rate (up to 146kW only) to obtain 2 mbar pressure at test point P5.

On units with a separate pilot line fitted check pilot gas pressure at test point P7 and reset governor as shown in Fig.4, if necessary, to 5mbar.

Additional lockout resets may be required to adjust pilot governor pressure due to the time allowed prior to lockout occurring.

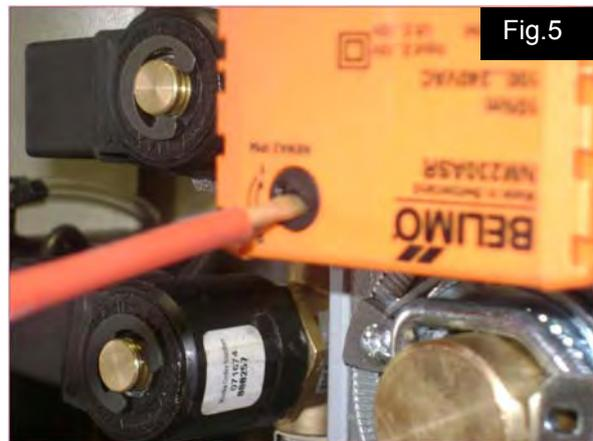
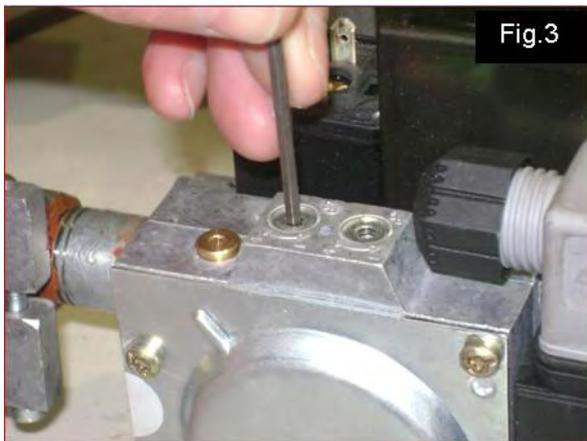
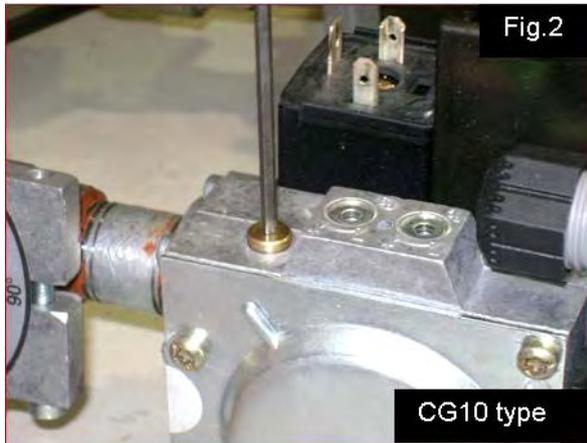

Open burner gas isolating valve V6 and reset the lockout condition. A purge will commence followed by pilot ignition and main flame ignition at low fire.

Override the gas control valve motor to open (see Fig.5) to hold the burner at high fire.

As the gas valve drives towards high fire the flame colour should be blue, with a maximum flame length of 250 - 300mm extending from the burner plates. If flame lengths in excess of 250-300 occur, or orange in colour, close burner isolating valve V6, until the correct length/colour is obtained.

Connect a manometer to pressure tapping point P1. Measure and record the main gas inlet pressure, which should be in the range of 17.0 - 100mbar (refer to data badge).

Connect a separate manometer across pressure tapping points P5 and P9 to obtain the differential gas pressure.

For burner differential gas pressures refer to section 3 technical data for required gas and burner types, i.e. natural gas (G20), NG2 standard burner.

Connect a manometer to pressure tapping point P3 and measure governor outlet pressure, which should be approximately 7.5 mbar (NG2 STD burner) or 13.0 mbar (NG1 VAV burner). If valve V6 had to be closed reduce governor outlet pressure and fully open valve V6.

To increase or decrease the gas supply

commence, followed by pilot ignition and lockout.

If no pilot is fitted then the pilot gas rate will

6. Commissioning & Testing cont.



CG type (1)

CG type (2)



Moduline type

Vivaro type



Honeywell type

pressure to the burner, turn adjuster clockwise to increase the governor outlet pressure, and anti-clockwise to reduce outlet pressure. (See Figs. 6 to 10 for valve variations). It is strongly recommended that a pressure gauge is connected to pressure point P3 when adjusting governor outlet pressure.

Note: DO NOT adjust governor pressure when setting low fire gas pressure.

If increasing the governor outlet gas pressure does not increase the burner pressure at high fire, then the gas control valve requires resetting.

As a cross check at high fire, measure the outside air temperature and subtract this from the duct discharge temperature, this should be 42° C .

Override the gas control valve motor to closed



Fig.11

to drive the burner to low fire.

The flame at low fire should be a small continuous blue flame, along the full length of the burner, with a temperature rise of 5°C maximum over the outside air temperature. The low fire valve setting may have to be adjusted to obtain this temperature rise if the main gas governor outlet pressure was increased to

obtain high fire setting.

To adjust the low fire setting, slacken the M6 nuts from the motor 'U' clamp around the valve spindle (see Fig.11), and with a pair of grips on the valve spindle, minutely close the valve in small stages, until the 5°C temperature rise is obtained. Carefully tighten the 'U' clamp on to the valve spindle shaft, ensuring the shaft does not move.

Irrespective of low fire temperature rise, ensure that a good flame is present.

Override the gas valve motor to open and then back to closed to ensure the low fire setting has not altered.

The high fire stop has been factory set to ensure the valve opens fully, and should not require adjusting.

To ensure that the burner ignites smoothly and consistently at low fire.

Repeat this 4-5 times to ensure trouble free ignition.

MUA only

With burner firing a minimum rate connect both ends of a manometer to the tapping points on the pressure switch sensing tubes, to measure and record the differential air pressure across the profile plate at full fresh air. Reading should be between 1.25-1.5mbar.

Adjust air pressure switch, screwing clockwise, increases the pressure range, anti-clockwise reduces the pressure range. (See Fig.12)

The ideal setting is normally 0.75mbar. Setting higher than 0.75mbar may give rise to nuisance



Fig.12

lockouts.

Ensure gas valve motor rotational switch is set to normal position.

VAV only

There are no profile plates on these units. The blown burner requires the system to have two air pressure switches to confirm both the combustion and main airflows respectively. Check airflow of the combustion air fan. Pressure in the burner chamber should be

6. Commissioning & Testing cont.

1.25mbar. The pressure differential should be measured across the two test point fittings labelled P8 and P9 on the process diagram (see Fig.13), and located in the controls panel. The pressure can be adjusted by first

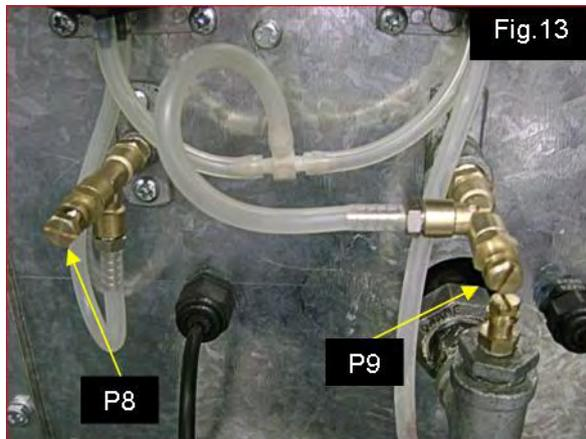

slackening the locknut with a 17mm spanner, then closing or opening the sliding inlet to the combustion fan/s by screwing the adjuster rod in or out (See Fig.14).

Ensure slide is locked in position once pressure

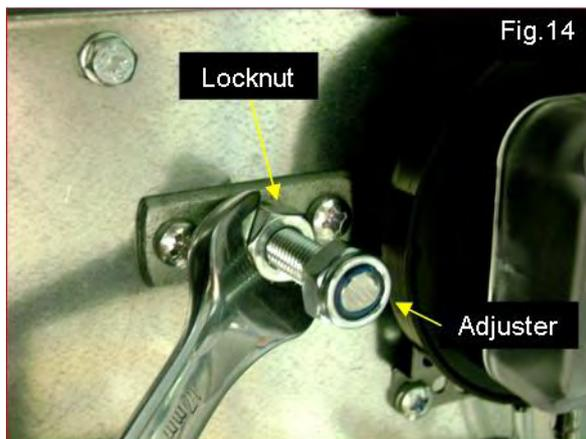

is correctly set. Ensure combustion air pressure switch is set to 0.75mbar. Minimum air volume for VAV is factory preset.

Ensure main pressure switch is set to 1.25 mbar. Check maximum airflow of unit using suitable air volume measuring device. If air volume varies to that specified on the data label it will be necessary to change the fan speed.

Consult the manufacturer for advice and guidance before making any changes.

Safety checks

Ensure the system enable relay and burner enable relay are both overridden on, and the burner is firing.

Close burner isolating valve V1, lockout will occur. Open valve and reset lockout condition. Remove air sensing tube from air pressure

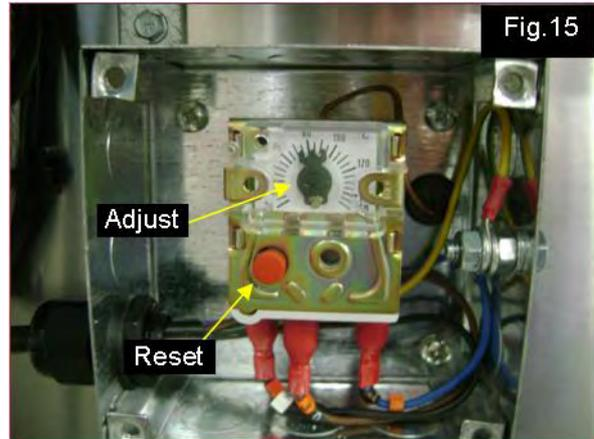

switch, heater will lockout on air failure. Replace and reset.

Adjust overheat thermostat set point down until heater goes to lockout. Reset temperature to 85°C and reset thermostat by depressing red pushbutton on front of unit (See Fig.15)

Place multimeter across flame rod disconnection tab located on control panel terminal rail. Set meter to read μA . Remove disconnection tab. Flame current should be 1.5 μA . Replace disconnection tab.

Remove disconnection tab with heater running, heater should lockout in less than 1 second.

Combustion DP, DP VAV, AH, AH VAV

Component	Limiting concentration	
	ppm	% V/V
Carbon Monoxide CO	10	0.001
Carbon Dioxide CO ₂	2500	0.25
Nitric Oxide NO	5	0.0005
Nitrogen Dioxide NO ₂	1	0.0001

The concentrations of oxides of carbon and nitrogen in the discharged air measured on the dry basis shall not exceed the figures shown in the chart below, the figures given as a rise in level, (i.e. discharge air concentration minus the inlet air).

The combustion levels are taken at the sample point in the discharge air directly in front of the

Component	Limiting concentration
Carbon monoxide CO	90 ppm (+/- 40 ppm)
Carbon dioxide CO ₂	1.1% (+/- 0.2%)

6. Commissioning & Testing cont.

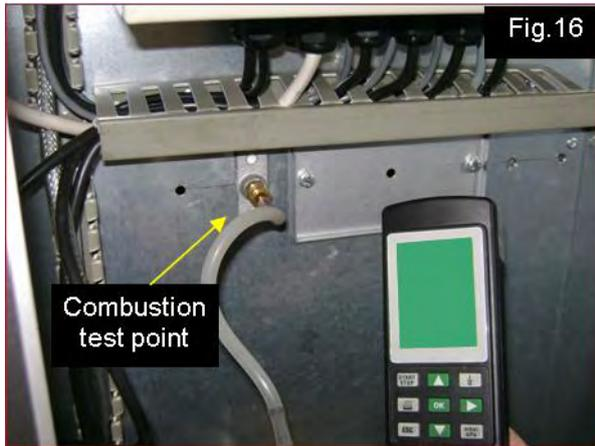

burner (250 mm centrally, see diagrams 8 and 9 and Fig.16) and should be measured using a standard combustion analyser. The combustion shall not exceed the figures shown in the chart on the previous page.

If the levels are higher than in the chart, check that the air flow rates (particularly the minimum air flow) are in accordance with the data shown in section 3. If not, adjust until the required emission levels are obtained.

Diagram 8: NG2 standard burner combustion sampling position

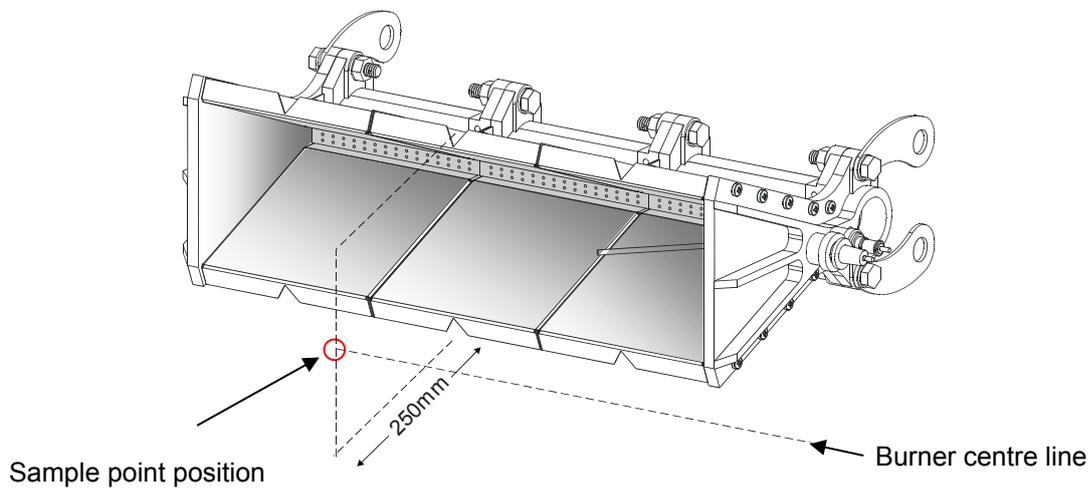
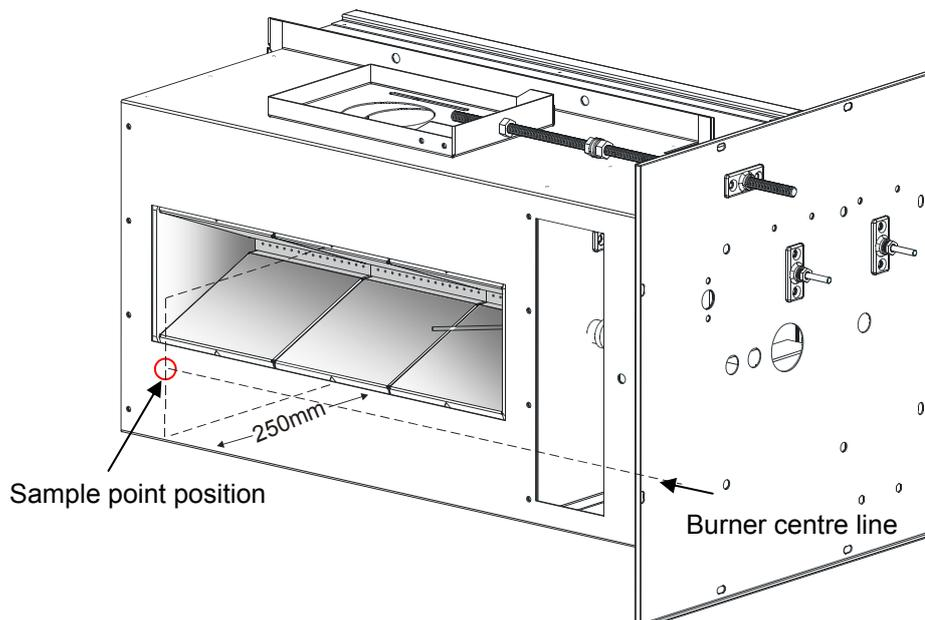

Diagram 9: NG1 VAV burner combustion sampling position



6. Commissioning & Testing cont.

Leak testing the gas line

The procedure should be used in conjunction with the process and instrumentation drawing.

1. Ensure that gas and electricity supplies are turned off and close manual valves V1, V6, V7 and V11.

Testing the pipework up to and including the upstream main safety shut-off valves:

2. Connect a suitable pressure gauge to pressure test point P2.

3. Open V1 to pressurise the governor assembly.

4. Close V1. Leave the system for 3 minutes and check for a fall in pipework pressure. If the pressure falls, open V1, and test for leaks with leak detection fluid. Make good as necessary and re-check.

Note: 3 minutes should be allowed for all pressure checks.

5. If external leaks are observed, the upstream main safety shut-off valve is passing gas.

To check this, remove the sealing screw on the pressure test point 2, and connect the pressure gauge to test point 4 and leave for 3 minutes with V1 still open. A rise in pressure will confirm that the main valve is passing gas.

Replace the valve and re-check for soundness.

Testing the downstream main safety SSOV

6. Close V1 and connect pressure test points P1 and P4 with a length of rubber tubing.

7. Open V1 to pressurise the assembly up to the burner isolating valve, V6.

8. Using a leak detection fluid check all joints downstream of the second safety shut off valve up to V6. If leaks are detected, close V1 and remake leaking joints. Repeat 7 and 8 to re-check after assembly.

9. If no external leaks are observed, close V1 and connect rubber tube to pressure test point P1 and P3 to pressurise the assembly between the two safety shut off valves.

Connect pressure gauge to pressure test point P4.

10. Open V1, any rise in pressure indicates the downstream safety shut off valve is passing gas. Replace valve and re-check for soundness.

Testing the start gas pipework

11. Connect pressure gauge to P2 and open V7 and V1 to pressurise the start gas line up to the first gas safety shut-off valve.

12. Close V1. Leave the system for 3 minutes and check the pressure gauge. If the pressure falls, open V1 and leak test the start gas pipework and re-test.

13. If no external leaks are evident the start gas safety shut-off valve is passing gas.

To check this, replace the sealing screw on the pressure test point P2 and connect the pressure gauge to test point P6 and leave for three minutes with V1 still open. A rise in pressure confirms the upstream pilot valve is passing gas. Replace valve and re-check for soundness.

Testing the downstream pilot SSOV

14. Close V1 and V11, connect pressure test points P1 and P7.

15. Open V1 to pressurise the assembly up to the isolating valve, V11.

16. Using a leak detection solution, check all joints downstream of the second safety shut off valve up to V11. If leaks are detected close V11 any remake leaking joints. Repeat 15 and 16 to re-check after re-assembly.

17. If no external leaks are observed, close V1 and connect rubber tube to pressure test point P1 and P6 to pressurise the assembly between the two safety shut off valves. Connect pressure gauge to pressure test point P7.

18. Open V1, and rise in pressure indicates the downstream safety shut off valve is passing gas. Replace valve and re-check for soundness.

On completion of commissioning, all adjustable devices should be sealed with suitable tamper evident seal.

7.Servicing.

The servicing of these heaters must only be carried out by a competent person.

It is not recommended to service any heaters designed for permanent outdoor installation in wet conditions.

It is recommended that the heater is serviced twice a year, a major service should be carried out prior to heating season, and a minor service after 2000 running hours.

After servicing the heater should be re-commissioned.

Routine servicing

Note: Isolate electricity supply and gas supply before servicing.

Access to the fan, motor, drive belts and burner is through the access doors on the side of the heater.

Remove and clean spark igniter with a wire brush. Replace it every two years.

Inspect and clean the flame rod with a dry clean cloth to ensure freedom from dirt and moisture. Replace the flame rod when showing signs of excessive wear.

Remove protection boot from the spark electrode cap, with a clean cloth wipe clean both the HT and flame probe leads.

Check fan belts for wear and tension after 2000 hours of operation.

The tension of each belt should be determined using a belt tensioner.

Check condition of burner ports, if necessary, clear the ports using either a 1.8mm long series drill (NG2 standard burner) or 2.0mm long series drill (NG1 VAV box burner)

Note: Check stainless steel mixing plates for cracking.

Inspect the entire external system for signs of leakage, wear or general damage.

Check fan bearing for grease nipples, only the smaller range of heaters are fitted with "sealed for life" bearing, if fitted with nipples, re-grease using Shell Alvania R3 grease or similar.

Leak test the pipework and safety shut-off system in accordance with the procedure, and check gas soundness.

Belt tensioning

- Calculate the deflection distance in mm on a basis of 16mm per metre of centre distance.
- Set the lower marker ring at the deflection distance required in mm on the lower scale.
- Set the upper marker ring against the bottom edge of the tube.
- Place the belt tension indicator on top of the belt at the centre of the span, and apply a force at right angles to the belt deflecting it to the point where the lower marker ring is level with the top of the adjacent belt.
- Read off the force value indicated by the top edge of the marker ring.
- Compare this force to the kgf value in the table overleaf.
- If a belt tension indicator is not available, a spring balance and rule will suffice.

Important

After the drive has been running for approximately 30 minutes, the tension should be checked and re-adjusted to the higher value, if necessary.

See table overleaf.

7. Servicing cont.

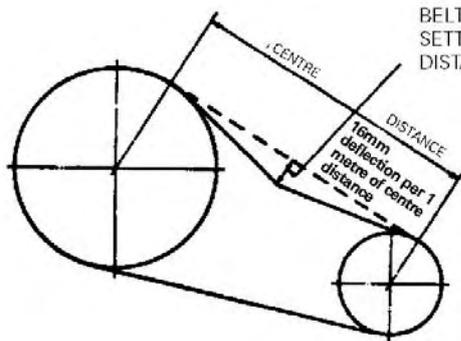

BELT TENSION INDICATOR APPLIES SETTING FORCE AT MID CENTRE DISTANCE

The setting forces below are designed to cover a wide range of drives. A precise setting force for individual applications can be calculated. Please consult your local Authorised Distributor or use the 'Fenner Select' design software at www.fptgroup.com

SETTING FORCES

Belt Section	Setting force to deflect belt 16 mm per metre of span				
	Small pulley diameter (mm)	Basic setting forces Newtons (N) kilograms (kgf)		1.25 x setting forces Newtons (N) kilograms (kgf)	
SPZ	56 to 71	16	1.6	20	2.0
	75 to 90	18	1.8	22	2.2
XPZ & OXPZ	95 to 125	20	2.0	25	2.5
	over 125	22	2.2	28	2.8
SPA	80 to 100	22	2.2	28	2.8
	106 to 140	30	3.0	38	3.9
XPA & OXPA	150 to 200	36	3.7	45	4.6
	over 200	40	4.0	50	5.1
SPB	112 to 160	40	4.0	50	5.1
	170 to 224	50	5.1	62	6.3
XPB & OXPB	236 to 365	62	6.3	77	7.9
	over 365	65	6.6	81	8.3
SPC & QXPC	224 to 250	70	7.1	87	8.9
	265 to 355	92	9.4	115	12.0
8V	over 375	115	12.0	144	15.0
Z	335 & above	150	15.0	190	19.0
A (& HA banded)	56 to 100	5 to 7.5	0.5 to 0.8		
B	80 to 140	10 to 15	1.0 to 1.5		
C	125 to 200	20 to 30	2.0 to 3.1		
D	200 to 400	40 to 60	4.1 to 6.1		
	355 to 600	70 to 105	7.1 to 10.7		

FENNER BELT TENSION INDICATOR

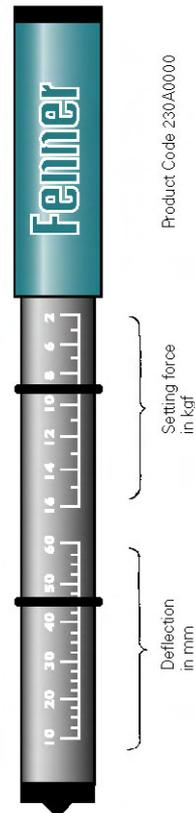

8. Troubleshooting.

General

Should either the burner fail in operation, or its light up sequence fail, the following procedures should be carried out.

Check that the connectors to the spark electrode and flame detector are securely fixed, and that there has been no interruption to the gas, air or electricity supplies.

Flame failure lockout is indicated on the heater via a red indication lamp. Reset can be achieved by:

a. Depressing the Satronic flame programmer RESET button, situated within the heater control panel.

b. Depressing the reset button on the front of the electrical control cabinet.

If the burner still fails to ignite, proceed to carry out systematic checks in accordance with the fault finding guide.

Control system fault finding

The individual phases of the programming sequence on the Satronic DMG970 (see Fig17 overleaf). Are displayed in the form of flash codes. The following messages can be distinguished (see diagram opposite):

Message	Flash - code
Waiting for air proving switch	.
Pre-purge tv1	.
Pre-ignition tv2	.
Safety time ts	■ .
Delay 2nd stage tv2	■ .
Running	_
Low mains voltage	■ ■ _
Internal fuse defect >control box defect	■ -

Description

- | = short pulse
- = long pulse
- . = short pause
- _ = long pause

8.Troubleshooting cont..

Error diagnosis

Error message	Flash - code	Possible fault
Lock out safety time	■ ■ ■ ■	Within lockout safety time no flame established
Stray light	■ ■ ■	Stray light during monitored phase. Detector may be faulty
Air proving switch in closed position	■ ■	Air proving switch contact welded
Air proving switch time-out	■ ■	Air proving switch does not close within specified time
Air proving switch opened	■	Air proving switch opens during start or operation
Loss of flame	■ ■ ■ ■	Loss of flame during operation

Flash code for manual lockout

Manual / external lockout	■ ■ ■ ■ ■ ■ ■ ■ ■ ■
---------------------------	---------------------

Sequence diagram:



General troubleshooting

Symptoms	Possible causes	Remedy
Heater will not start.	No power supply.	Turn on main isolator, re-check.
	Fuse blown.	Find fault. Replace fuse.
	Fan on overload.	Find fault. Reset overload.
	Heater locked out.	Reset lockout.
	Overheat thermostat activated.	Manually reset and check setting is 85°C.
	Micro-processor not programmed.	Set up programmer.
Programmer cycles continuously	Air pressure switch not acting. Possibly stuck.	Reset pressure, or replace faulty switch
Programmer locks out	No gas.	Turn on gas. Check pilot solenoid is opening.
	No spark.	Check spark lead and gap.
	Insufficient airflow.	Check for: belts slipping, duct blocked, filter blocked.
	Flame not seen by flame probe.	Check probe lead, cap, replace faulty flame probe.
	Flame signal not accepted by programmer.	Check programmer. Replace programmer.
Programmer locks out (when flame is on).	Unstable main flame.	Check fan belts for slipping.
	Lack of gas.	Check gas supply.

Note: In the event that the fault cannot be traced, it is recommended that a competent suitably qualified service engineer be contacted.



Fig.17

Lock out diagnostics:

In the event of a failure the LED is permanently illuminated. Every 10 seconds the illumination is interrupted by a flash code which indicates the cause of the failure, therefore the following sequence is performed, which is repeated until the unit is reset. (See sequence bar diagram below)

9. Removal & Replacement Of Parts.

Note: Replacement of components should only be carried out by a competent person. Isolate electrical and gas supplies before replacement of any parts.

Check for gas soundness after replacing gas carrying components. Access for replacement of the main burner assembly, ignition electrode, flame electrode, fan, motor, drive belts, is via the access doors in the fan section. Inadvertent substitution or replacement of similar components, particularly those with plug-in bases, could be hazardous.

Main burner assembly

Disconnect main gas supply union and pilot gas supply, HT cable and flame rod connections. Unbolt burner straps from the burner supports and remove assembly from heater. If necessary, replace any damaged sections as required, re-join flanges using special burner gasket.

Replace burner assembly in reverse order to removal. Check operation and combustion as detailed in the commissioning instructions.

Ignition electrode

Isolate electrical supply, remove HT cable, unscrew ignition electrode from burner body, replace with new and reconnect HT cable, and protective boot.

Ignition transformer

Isolate electricity supply, disconnect HT lead. Disconnect cable from terminal block. Unbolt ignition transformer and remove. Refit new transformer, reconnect cables and HT lead then test.

Flame electrode

Isolate electrical supply, remove cable from flame electrode, unscrew old rod and replace with a new one, bending the probe through 45° so that the probe runs parallel to the burner plates. It will be necessary to straighten the old probe prior to unscrewing from the burner.

Modulating gas valve control unit

Isolate electric supply, unbolt motor clamp from valve spindle and remove motor from motor mounting bracket, replace and re-connect. Care should be taken not to move the valve spindle, as this will alter the low fire setting, requiring the heater to be re-commissioned.

Gas train components

Isolate gas and electricity supply; disconnect electrical connections to valves and modulating valve motor unit. Unscrew unions on gas train, replace components where necessary, reseal using approved thread sealing compound, re-fit and tighten unions. Gas train should be leak tested and re-commissioned.

Drive belts

Access is via the access doors in the fan section. Loosen motor adjusting screw, remove belts. Replace belts and re-tension.

Fan drive motor

Disconnect cable to motor. Loosen motor slide plate by adjusting screw, then remove belts. Remove motor pulley and bush. Unbolt motor from slide plate, re-fit motor, pulley and bush. Check both motor pulley and fan pulley are parallel and in alignment. Re-fit belts and re-tension.

Duct sensor

Isolate electrical supply, remove cover from sensor, unscrew cable terminals, remove cable, remove fixing screw and withdraw. Refit new duct sensor in reverse order.

Room sensor

Unclip room sensor, unscrew cable terminals, and remove cables. Refit new room sensor in reverse order.

Air differential pressure switch

Remove cover of pressure switch, terminal box. Disconnect cables, remove sensing tubes and unbolt pressure switch from mounting bracket, replace the switch, re-connect the sensing tubes, re-connect the cables. Re-commission the differential pressure switch by setting to 0.5 mbar and check operation. It will send the heater to lockout if adjusted any higher than the air pressure differential.

Control panel components Burner programmer

Unscrew body from plug-in terminal base and replace.

Indicators

Unscrew lamp cover, remove bulb, and replace with new.

9. Removal & Replacement Of Parts cont.

Relays

Unplug relay body and replace with new.

Motor MPCB (protective circuit breaker)

Disconnect outgoing motor cables, loosen overload to contactor connecting screws, and replace overload unit, reconnect cables.

Control MCB

Loosen cable terminal screws and remove the incoming and outgoing cables. Unclip the MCB from the Din rail. Replace MCB, re-connect cables.

Overheat device

Isolate electrical supply, remove cables, then

remove fixing screw. Remove clip from end of phial inside heater then withdraw phial and capillary tube through hole in cabinet and, where applicable through hole in conduit box. Replace with a new unit, set to 85°C, and test as described in the commissioning section.

BMS outstation (if applicable)

Remove all wires from the outstation, noting their positions, and unscrew from base plate. Refit new controller and rewire, ensure all connections are in the correct positions. The controller will require re-addressing, and the controller software downloading. This should be carried out by a competent engineer or agent.

10. Spare Parts.

The following table shows a list of recommended spares.

Item	Description	Part No.	Item	Description	Part No.
	Spark electrode	N1014		¼" BSP solenoid valve	N3041
	Flame probe M18x150	N1007		⅛" BSP solenoid valve	N3055
	Flame probe ¼" NPTx190	N1024		Modulating control motor NM24A SR	N9002
	HT plug cap	N1008		Modulating control motor NM230A SR	N9028
	HT lead	N1012		Overheat device	N7044
	Satronic DMG 970	N1023		Alternative air pressure switch JD2	N3038
	Vee belts	See technical specification		Air pressure switch Krom Schroder	N3069
	Ignition transformer	N1010		BMS outstation (if applicable)	See wiring diagram
	Duct sensor/ thermocouple	See wiring diagram		Stainless steel burner mixing plate	N0006
				Angled stainless steel- burner mixing plate (T or H sections only)	N0007

11. User & Operating Instructions.

1. Introduction

The Econoair Direct Fired (DF) heater is a fully automatic, highly efficient source of heat.

It is of solid construction with a high finish, and properly cared for will give you as many years of reliable service.

It will provide you with warm air in the winter, and ventilation air in the summer, and at all times generate a clean, fresh atmosphere.

Your heater carries a 12 month warranty on all components.

The heater once properly installed and commissioned is fully automatic. No adjustments are necessary.

2. Lighting instructions

During normal operation the electricity and gas supplies can be left turned on, and as such the heater will light up under fully automatic control.

Use the display device, approved controller, or BMS system where applicable to bring the heater on using the time clock functions.

3. Shut down

For short periods

Use the display device, approved controller, or BMS system where appropriate to turn the heater off using the time clock functions .

For long periods

Turn OFF the gas and switch OFF the electrical supply to the heater. The display device or approved controller will have a battery back-up of its program.

Note: Using this procedure the frost protection will not function.

4. Care of your heater

Keep the area around the heater free from rubbish or debris.

Ensure that there is an unrestricted flow of fresh air to the heater inlet.

Do not put anything on top of the heater or lean anything against it.

Use a damp cloth and mild detergent, if necessary, to clean the external surfaces of the unit.

Your installer will have advised you of any adverse ambient conditions at the time of installation. Please ensure that any subsequent changes in your premises do not result in any deterioration of the heater's environment.

Your heater should be regularly maintained.

5. Servicing

We recommend that the heater be serviced by a competent engineer every 6 or 12 months, depending on usage.

Should your heater require any spare parts, you will find that the components are readily available.

See below for contact details.

6. Understand your heater

It is helpful for you to understand the automatic function of your heater. The automatic light up is initiated by the control station, and then controlled and monitored by the Satronic programmer fitted in the control panel of the heater.



STOKVIS ENERGY SYSTEMS,
96R WALTON ROAD,
EAST MOLESEY,
SURREY,
KT8 0DL
TEL: 0208 7833050 / 08707 707 747
FAX: 0208 7933051 / 08707 707 767
EMAIL: info@stokvisboilers.com
WEBSITE: www.stokvisboilers.com

