

Concrete Seating

Metrolinia NEW!



Metrolinia Example

In today's ever changing urban landscapes, the need to provide flexible seating arrangements is ever increasing. Gone are the days when a 1.8m bench or seat will satisfy the needs of every landscape. These items still have a place within the linear environment of a typical street; however, the contemporary urban realm demands much greater flexibility.

Modular seating can be used effectively to define a landscape and provide more diverse use over and above traditional linear seating.

The flexibility of modular seating makes it suitable for a wide range of environments because:

- Space can be defined in more interesting ways with collections of units, with limitless configurations being achievable and precisely tailored to need
- In large spaces, it can be used to define areas of use and demarcate boundaries. The limited size of units allows them to be easily moved if space is needed
- Modular units encourage less prescribed use, people can perch or sit and squeeze on in a more relaxed manner
- Not only do modular systems provide effective use of space, they can have more presence. Particularly in large spaces, they can act as focal points
- With a change in urban lifestyles, the demand for new products and spaces to contain them is growing. Seating which is more relaxed encourages conviviality and can improve social interaction.

Concrete Seating

Metrolinia NEW!



SEAT SECTION



BENCH SECTION



LARGE INTERMEDIATE

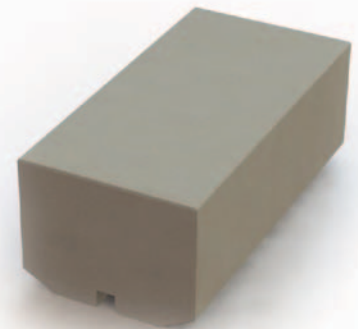

INTERMEDIATE

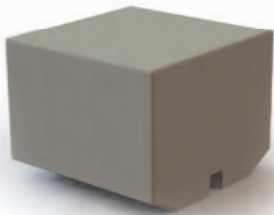

PLANTER



T JUNCTION/X JUNCTION

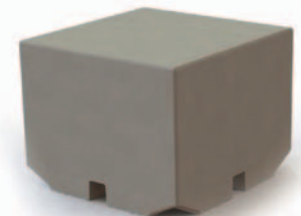

RADIUSED END BLOCK



END BLOCK

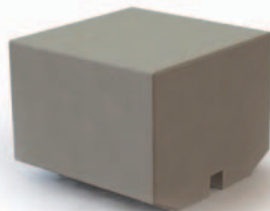

STAND ALONE BLOCK



RADIUSED CORNER SECTION



There are 10 components within the Metrolinia range which can be used to create your seating configuration. For linear runs, an end block is always required. Should you wish to create a circular seating arrangement, then end blocks are not required. Add some planting arrangements into your configuration using the planter module.

Once you have a design in mind, we suggest that you contact our sales team who can assist you with creating your design. Where required, Marshalls Street Furniture Design Team can create a rendered example of your seating configuration.

Concrete Seating

Metrolinia NEW!



Coordinate with Metrolinia Block Paving

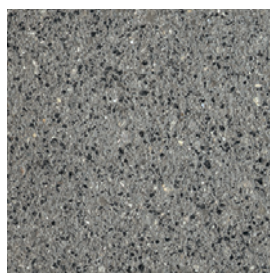

City Charcoal Grey



City Silver Grey

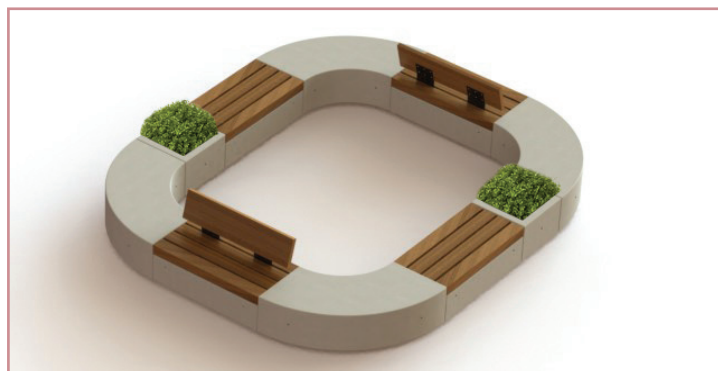

Product Description	Length (mm)	Width (mm)	Height (mm)	Weight (mm)
Seat Section	1200	612	456	765
Bench Section	1200	612	456	705
Large Intermediate	1200	600	456	830
Intermediate	600	600	456	415
Planter	600	600	456	255
T Junction	600	600	456	415
X Junction	600	600	456	420
Radiused End Block	600	600	456	405
End Block	600	600	456	625
Radiused Corner Section	1200	1200	456	980
Stand Alone Block	600	600	456	375

Concrete Seating

Igneo



Igneo Seat and Litter Bin and Appia Seat/Bollard, Seaton

Igneo seating is a modular system that offers contemporary styling, combined functionality and maximum robustness. Igneo seating can be specified to any length, based on the module sizes below, dependant on the location and the amount of seating places required.

Igneo seating provides the durability that is achieved from cast concrete. Extremely hard wearing, concrete weathers naturally and requires minimal maintenance. Seating has a high vandal resistance and has an anti-graffiti coating as standard.

Arm rests can be installed between sections. Manufactured in Ferrocast® polyurethane they too will have a long life span and require little maintenance. Arm rests can be ordered in any standard RAL colour. For more information on the colour options, please refer to page 425.

Seating sections are free standing and are pinned to each other to ensure that they remain in place and continue to provide clean, continuous lines.

Crash tested PAS 68 version also available see page 116.



Igneo Seat, Armrest Detail

IGNEO LEFT SECTION

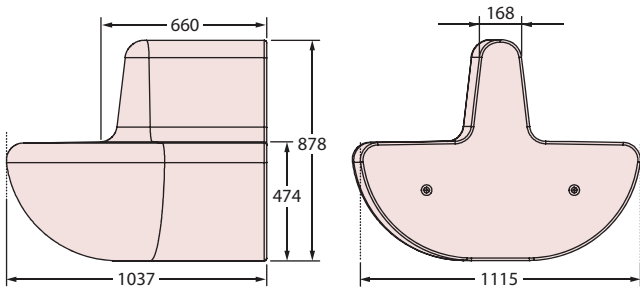

IGNEO RIGHT SECTION

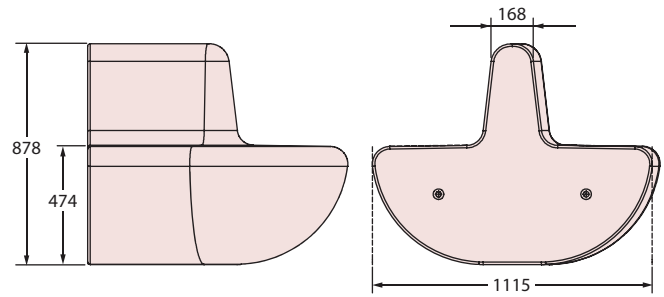
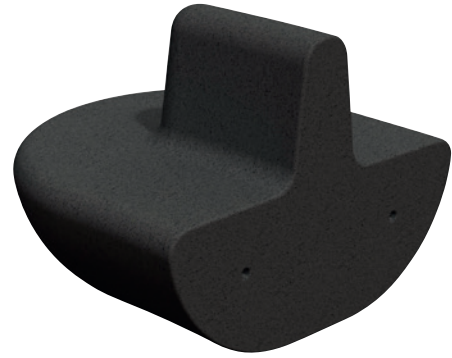

IGNEO CENTRE SECTION

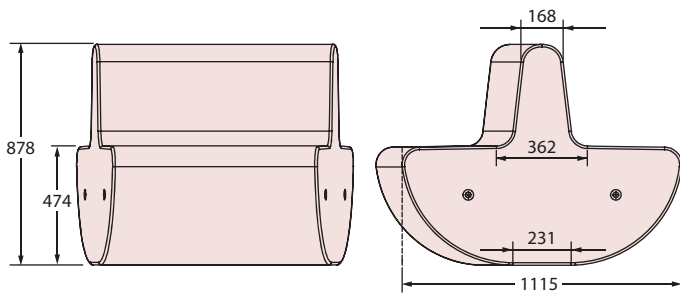
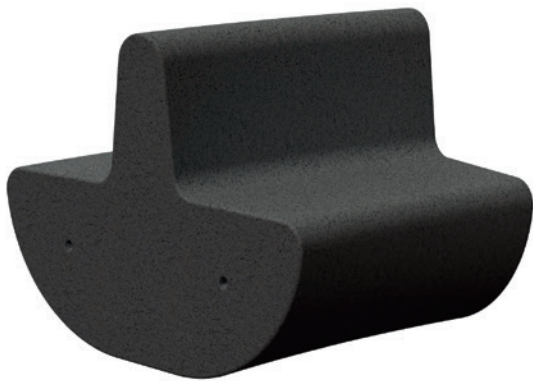

IGNEO CHAIR

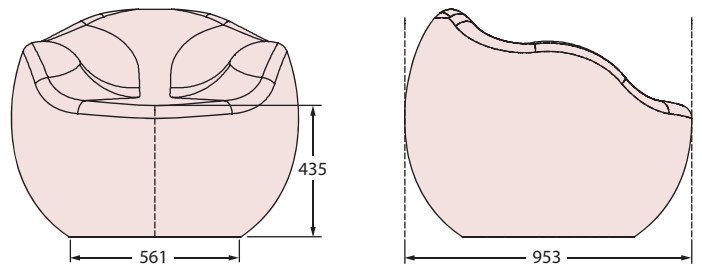

Product Description	Seat Span (mm)	Seat Height (mm)	Weight (kg)	Standard Finish	Fixing Method
Igneo Left Section	1037	474	1021.53	Charcoal	Free Standing
Igneo Seat Right Section	1037	474	1203.02	Charcoal	Free Standing
Igneo Seat Centre Section	1102	474	1021.3	Charcoal	Free Standing
Igneo Chair	953	434	1110.55	Charcoal	Free Standing

Concrete Seating

Barioni



Barioni Bench

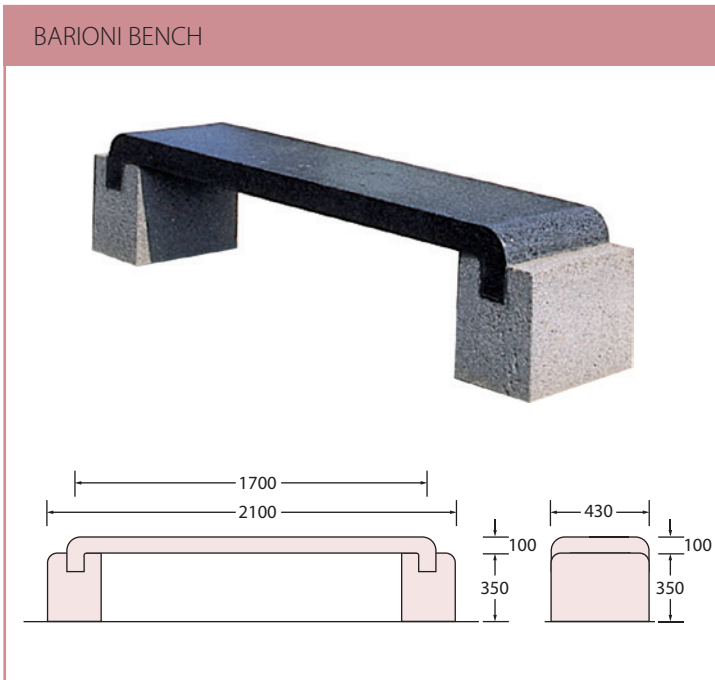

- The Barioni bench combines a curved top with rectangular ends. The bench top is etched and sealed in anthracite basalt concrete, whilst the ends are finished with a fine shot blast, creating a lightly textured surface.
- It is supplied free standing only and delivered to site fully assembled.
- Other colours can be commissioned on request. Please contact our Sales Team for more details.

Product Description	Seat Span (mm)	Seat Height (mm)	Weight (kg)	Colour	Standard Finish	Supplied Assembled	Free Standing	Fixing Method Surface Mount	Ground Fixed
Barioni Bench	2100	450	392	See Swatch	Fine Shotblast Ends*	■	■		

*The Barioni bench features an etched and sealed top

Concrete Seating

Scala



Scala Bench (Stainless Steel Section)

SCALA BENCH WITH STAINLESS STEEL SECTION

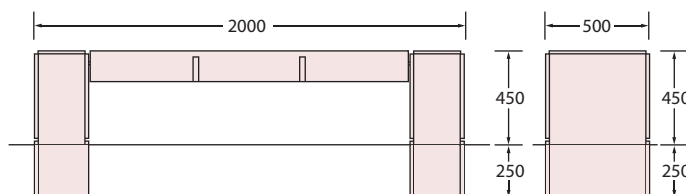

SCALA BENCH WITH TIMBER SECTION

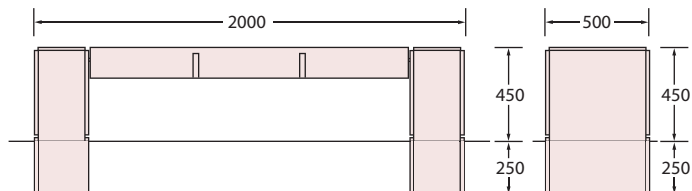

SCALA BENCH WITH STEEL SECTION

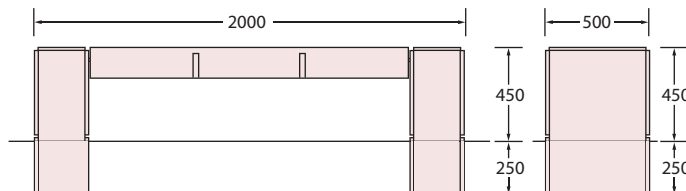

Product Description	Seat Span (mm)	Seat Height (mm)	Weight (kg)	End Colour	End Finish	Section Finish	Fixing Method		
							Free Standing	Surface Mount	Ground Fixed
Scala Bench SS (Stainless Steel Section)	2000	450	200	See Swatch	Etched & Sealed	Grade 316 Stainless Steel		■	■
Scala Bench (Timber Slats)	2000	450	200	See Swatch	Etched & Sealed	Treated Hardwood		■	■
Scala Bench (Steel Section)	2000	450	200	See Swatch	Etched & Sealed	PC RAL Colour		■	■

*Prices shown for silver grey finish. Please contact sales office for alternative colours

Concrete Seating

Bespoke Products and Special Commissions



Bespoke Seats/Bollards, Kings Dock, Liverpool

Special commissions may be undertaken to create truly unique furniture. From one off pieces to match existing installations, to whole systems that will create a statement scheme.

Bespoke pieces will be created in the design, colour and finish of your choice. Design elements from different materials such as steel, stainless steel or Ferrocast® can be incorporated. Pieces can be commissioned in colours to contrast with or complement Marshalls paving to create a fully integrated appearance. Four standard finishes are available and text or detailing can be sandblasted onto the piece.

Marshalls specialists will offer technical advice to take creative concepts to production. Design, manufacture, installation, scheduling and costs will be taken into account to ensure the process runs smoothly.



Bespoke Seating, Kings Dock, Liverpool



Monoscape Cube with sandblasted logo

Concrete Seating

Quadro Bench

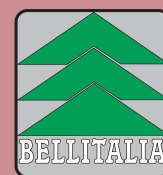

Quadro Bench

QUADRO BENCH

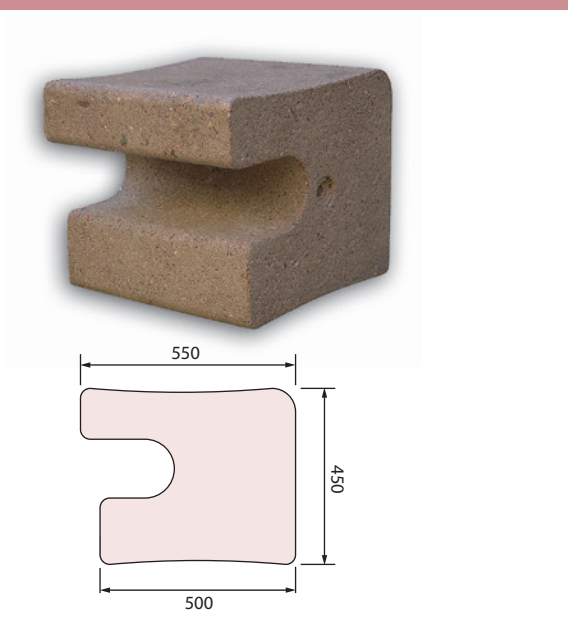

Bellitalia Concrete Seating is stylish and functional, pieces are manufactured using steel-reinforced precast white or grey concrete, vibrated, sandblasted and protected using an acrylic resin coating. Pieces are supplied pre-assembled. The total weight of the benches mean that additional anchorage to the ground is not required. When installing, use the appropriate lifting techniques to lift and locate benches safely.

Quadro Bench: A modular monolithic bench featuring anatomically shaped seat for comfort, each modular element is produced in a single concrete pouring.

Product Description	Seat Span (mm)	Seat Height (mm)	Weight (kg)	Standard Finish	Supplied Assembled	Fixing Method Free Standing
Quadro Bench	500	450	243	Clear Acrylic Resin	■	■