

SHOWERMATE ECO

Standard Single Pump

Showermate ECO Standard Single pumps are designed to improve water supplies to single taps or to pump blended water from a shower mixer.

Suitable for positive head applications only.



Features

- 3 year guarantee
- 2.0 bar option
- Suitable for positive head applications
- High quality compact plastic pump supplied with 15 mm flexible hoses with integral ISO valves on inlets
- Quiet operation
- WRAS approved product
- Intermittently rated
- Anti-vibration feet
- EPDM/PTFE/Al. Oxide seal
- Pre-wired with 1.5 metre power cable

Application

- Boosting hot or cold water supplies to a single tap or the blended water between a shower valve and shower head in low pressure gravity systems
- Suitable for use where there is already more than 1 litre/min flow from the outlet(s) to be boosted

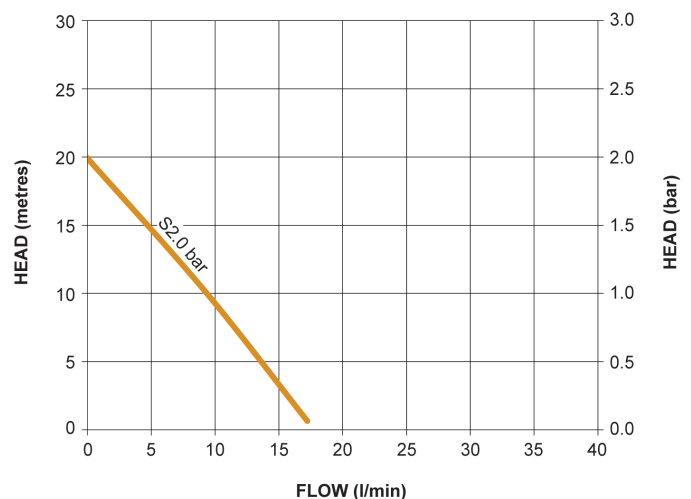

Pump Model		S2.0 bar Single 46503
General	Guarantee	3 years
	WRAS approval	1504701
	Approvals	WRAS, CE
Features	Pump type	Peripheral
	Mechanical seal	EPDM / PTFE / Al. Oxide
	Anti-vibration feet	✓
	Flexible hoses	2
	Dry run protection	✓
	Typical noise	45 dB(A)
Materials	Pump body	Plastic
	Impeller	Plastic
Performance	Maximum head - closed valve	2.0 bar (20 metres)
	Performance @ 9 l/min	1.0 bar (10 metres)
	Performance @ 18 l/min	0 bar
	Maximum flow	18 l/min
	Maximum static inlet pressure	10 metres
	Maximum working pressure*	300 kPa (3 bar)
	Maximum ambient air temperature	40 °C
	Min / Max water temperature**	Min 4 °C / Max 65 °C
	Flow switch sensitivity	0.8 l/min (approx)
Connections	Pump connections	G ¾ male
Flexible hoses	Connections (UK model)	G ¾ female x 15 mm push-in x 200 mm long, isolating valves on inlet hoses
Motor	Type	Induction, auto-reset thermal trip
	Duty rating	Int (S3) 30 mins on/30 mins off @ 9 l/min
Electrical	Power supply (Vac/Ph/Hz)	230 V a.c. / 1 / 50 Hz
	Current - full load	1.0 Amps
	Power consumption - P1	215 Watts
	Fuse rating	5 Amps
	Power cable length	1.5 metres (pre-wired)
Physical	Enclosure protection	IP22
	Length	208 mm
	Width	132 mm
	Height - excluding hoses	166 mm
	Weight - including fittings	3.4 Kg

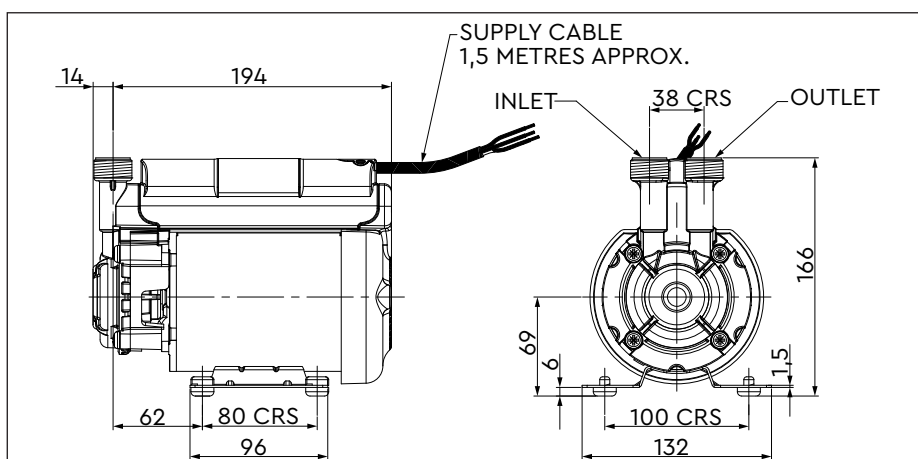

* The maximum pressure that can be applied to the pump under any installation conditions.

** A stored water temperature of 60 °C is considered sufficient to meet all normal requirements and will minimise deposition of scale in hard water areas.

Stuart Turner Limited reserves the right to amend specifications without notice.

Stuart Turner Ltd, Henley-on-Thames, Oxfordshire RG9 2AD Tel: +44 (0) 1491 572655 Fax: +44 (0) 1491 573704
TechAssist Helpline +44 (0) 800 31 969 80
www.stuart-turner.co.uk

Pt. No. 19975 Issue 4719/2-02