

MAINSBOOST

Mainsboost Flomate MBF 60 / MBF 80

Designed for higher occupancy properties and to fit neatly within a standard 500 mm kitchen base unit.

Mainsboost Flomate 60 and 80 products can be connected directly to the incoming mains and will deliver up to 16 litres/minute flow at 3.2 bar pressure to multiple outlets within the property, up to the preset cut-in limit of the 60 or 80 litre pressure vessel, at which time the system will deliver 12 litres/minute until demand ends and the pressure vessel recharges.



Features

- 3 year guarantee
- Output flow rate up to 16 litres/minute
- Increases mains water pressure up to 3.2 bar
- 60 / 80 litre pressure vessel
- Quiet operation
- WRAS approved product
- Built-in bypass
- Automatic switching
- Dry run protection
- Continuously rated
- Robust brass construction
- Patent protected

Application

- Suitable for higher occupancy properties with typically up to two bathrooms, MBF 60/MBF 80 requires no on-site commissioning and fits neatly within a standard 500 mm kitchen base unit.

Description	Typical Run Time in Minutes	
	12 l/min	16 l/min
MBF 60-1-15	Continuous	8
MBF 80-1-15	Continuous	12

Pump Model		MBF 60-1-15 46631	MBF 80-1-15 46634
General	Guarantee	3 years	
	WRAS approval	1412081	
	Approvals	WRAS, CE	
Features	Pump type	Peripheral	
	Flexible hoses	2	2
	Pressure vessel size	60 litre	80 litre
	Pressure vessel water capacity	30 litre	40 litre
	Upstream line-in kit	15 mm	
	Dry run protection	✓	✓
	Noise	from 46 dB(A)	
Materials	Pressure vessel	Epoxy coated steel	
	Membrane	Butyl rubber	
	Pump body	Brass	
	Impeller	Brass	
	Mechanical seal	EPDM / PTFE / Al. Oxide	
Performance	Maximum head (closed valve)	3.2 bar (32 metres)	
	Maximum flow	16 l/min	
	Maximum working pressure*	450 kPa (4.5 bar)	
	Maximum ambient air temperature	40 °C	
	Min / Max water temperature	Min 4 °C / Max 35 °C	
	Flow switch sensitivity (approx)	0.6 l/min	
Connections	Pump connections	G ¾ male	
Flexible hoses	Connections	G ¾ female x 15 mm push-in x 200 mm long	
Motor	Type	Induction (thermal trip/auto reset)	
	Duty rating	Continuous (S1)	
Electrical	Power supply / phase / frequency	230 V a.c. / 1 / 50 Hz	
	Power consumption	365 Watts	
	Current (full load)	1.7 Amps	
	Fuse rating	5 Amps	
	Power cable (pre-wired)	1.5 metres	
Physical	Enclosure protection	IPX4	
	Width	480 mm	
	Depth	457 mm	
	Height (excluding hoses)	663 mm	852 mm
	Dry weight (including fittings)	19.7 Kg	23.9 Kg
	Filled weight (maximum)	49.7 Kg	63.9 Kg

* The maximum pressure that can be applied to the system under any installation conditions.

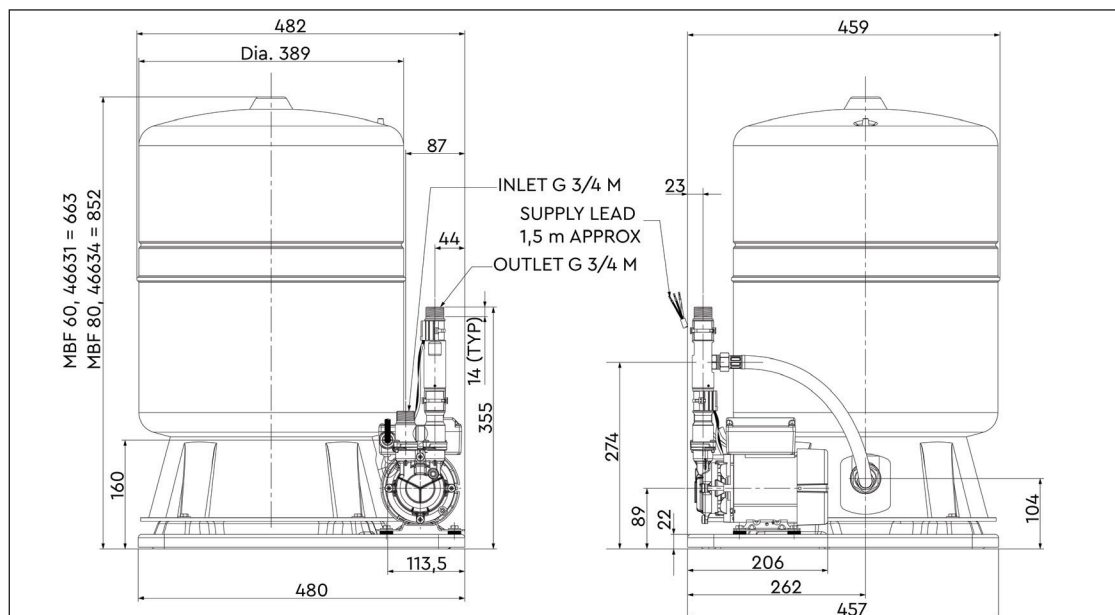

Stuart Turner Limited reserves the right to amend specifications without notice.