

WASTEFLO

BC3 – Boiler Condensate Pump

Designed to quietly and efficiently remove acidic residue water from a condensing boiler where access to an external vent pipe is not possible.

The compact Wasteflo Boiler Condensate Pump is supplied with a high capacity 2 litre tank and is suitable for use with any condensing boiler system.

Compact yet highly efficient, the Wasteflo Boiler Condensate Pump will move up to 288 litres per hour and up to 5 m head. The pump features three 27 mm inlets and one (6 or 10 mm) outlet and is the ideal solution for many domestic and commercial applications.



Features

- 2 year guarantee
- Pumps up to 5 m head
- Up to 288 litres per hour flow rate
- Twist and click non-return outlet barb
- Compact design
- Easy access high capacity 2 litre tank
- High level cut-out float switch
- Quiet operation
- Built in spirit level
- 2.0 metre power cable

Application

- Installing a condensing boiler in a basement where the appliance will be below the level of the main drain.
- Installing a condensing boiler in a location where access to the external drain is not possible or is prone to freezing.

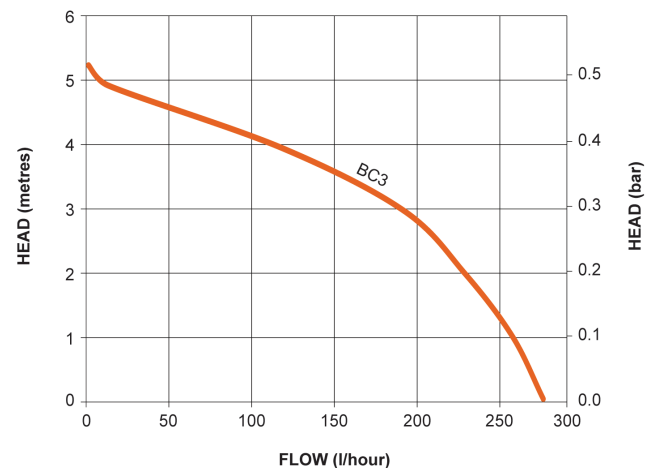

Pump Model		BC3 46663
General	Guarantee	2 years
	Approvals	CE
Features	Mounting position	Wall or floor
	Easy access tank	✓
	Twist and click non-return outlet	✓
	Built-in spirit level	✓
	Tank capacity	2 litres
	Safety cut-out	✓
	Thermal protection	✓
	Typical noise	55 dB(A)
Materials	Enclosure	Polypropylene
Performance	Maximum pumping distance – vertical	5 metres
	Maximum flow	288 l/hr
	Condensate pH	2.7 and above
	Maximum ambient air temperature	40 °C
	Min / Max water temperature	Min 4 °C / Max 60 °C
Connections	Inlet connections	3 x Dia. 27 mm
	Outlet connections	6 or 10 mm (ID)
Electrical	Power supply (Vac/Ph/Hz)	230 V a.c./1/50 Hz
	Current – full load	0.8 Amps
	Duty rating	Continuous (S1)
	Fuse rating	3 Amp
	Alarm	High level, n/c volt-free 3A
	Power cable length	2.0 metres
Physical	Enclosure protection	IP20
	Width	285 mm
	Depth	144 mm
	Height – excluding hoses	134 mm
	Weight – including fittings	2.5 Kg

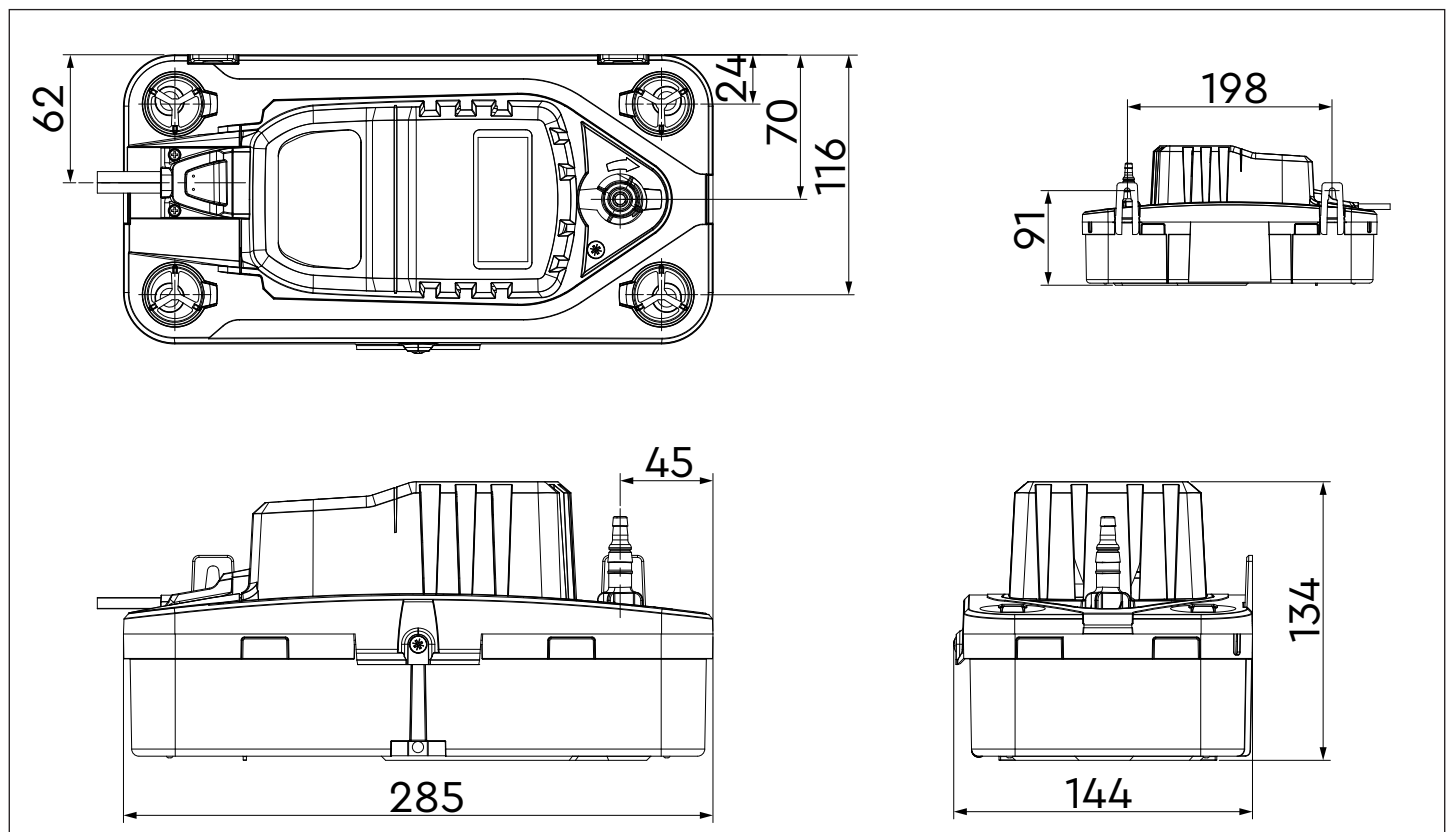

Stuart Turner Limited reserves the right to amend specifications without notice.