

# STUART

## PH TS Automatic Flow Switch Pumps

Ideal for the pressurisation of water to outlets in a positive head application, where an instant boosted supply is required from a simple to install package.

The range is suitable for commercial and domestic use, pumping hot or cold water.



### Features

- Peripheral pump
- Flow rates up to 43 litres per minute and heads up to 40 metres
- Top suction, vertical delivery connections
- Extended life seal
- Automatic flow switch control
- Brass pump head and impeller
- Continuously rated
- 2 year guarantee

### Application

- Ideal for the pressurisation of water to outlets in a positive head application, where an instant boosted supply is required from a simple to install package. The range is suitable for commercial or domestic use, pumping hot or cold water

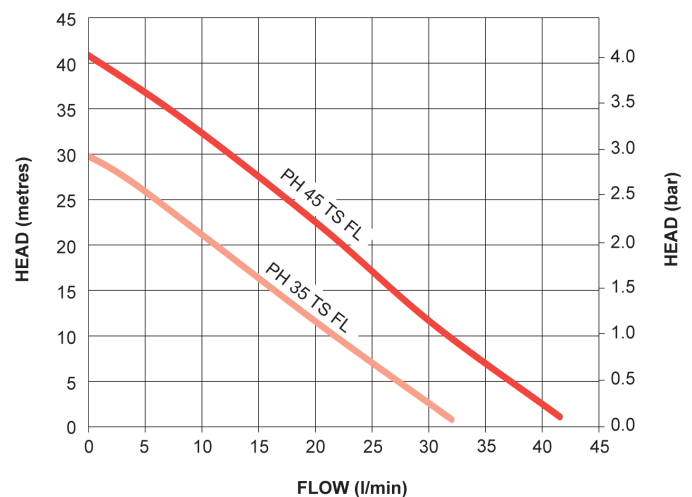

Pump Model		PH 35 TS FL 50 Hz 46522	PH 45 TS FL 50 Hz 46530
General	Guarantee	2 years	
	WRAS approval	Approved materials	
	Approvals	CE	
Features	Pump type	Peripheral	
	Pump control	Flow switch	
	Dry run protection	✓	✓
	Priming vent plug	✓	✓
	Typical noise	56 dB(A)	
Materials	Pump body	Brass	
	Impeller	Brass	
	Mechanical seal	EPDM / PTFE / Al. Oxide	
Performance	Maximum head – closed valve	3.3 bar / 33 metres	4.0 bar / 40 metres
	Performance	2.5 bar / 25 m @ 9 l/min	3.3 bar / 33 m @ 9 l/min
	Performance	1.4 bar / 14 m @ 18 l/min	2.0 bar / 20 m @ 18 l/min
	Maximum flow	32 l/min	43 l/min
	Minimum static inlet pressure	0.05 bar (0.5 metres)	
	Maximum static inlet pressure	1.0 bar (10 metres)	
	Maximum working pressure*	600 kPa (6 bar)	
	Maximum viscosity	50 secs redwood no. 1 9.5 centistokes	
	Maximum ambient air temperature	40 °C	
	Min / Max water temperature	Min 4 °C / Max 80 °C	
	Flow switch sensitivity	1 l/min (approx)	
Connections	Pump connections	G ¾ female (inlet) G ¾ male (outlet)	
Motor	Type	Induction, auto-reset thermal trip	
	Duty rating	Continuous (S1) @ 2.5 l/min and above	
Electrical	Power supply (Vac/Ph/Hz)	230 V a.c. / 1 / 50 Hz	
	Power consumption – P1	408 Watts	600 Watts
	Current – full load	1.8 Amps	2.6 Amps
	Fuse rating	5 Amps	
	Power cable length	1.5 metres (pre-wired)	
Physical	Enclosure protection	IP44	
	Length	209 mm	225 mm
	Width	132 mm	
	Height – excluding hoses	197 mm	
	Weight – including fittings	4.8 Kg	6.3 Kg

\* The maximum pressure that can be applied to the pump under any installation conditions.

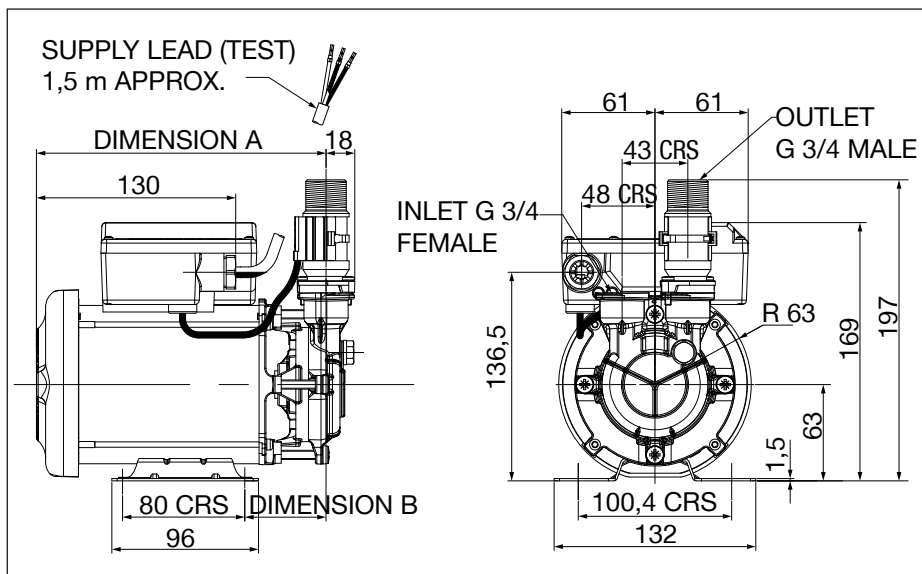

Pump Description	Dim. 'A'	Dim. 'B'
PH 35 TS FL	191 mm	53 mm
PH 45 TS FL	207 mm	53 mm

Stuart Turner Limited reserves the right to amend specifications without notice.