

Ventilation grilles for installation into walls, ceilings or rectangular ducts

Type AR



Return air grilles, made of aluminium, with fixed angled horizontal blades

Single return air grilles

- Nominal sizes 150 × 100 – 1200 × 600 mm
- Volume flowrate maximum 1202 l/s or 4327 m³/h
- Grille face made of aluminium with powder-coat finish
- Front border, 32 mm wide
- Visible screw fixing as standard

Optional equipment and accessories

- Grille face in RAL CLASSIC colours
- Attachments for opposed blade action volume control
- Screw fix border and border without punching available

Type		Page
AR	General information	AR - 2
	Basic information & nomenclature	AR - 4
	Quick sizing	AR - 5
	Order code	AR - 6
	Dimensions and weight	AR - 8
	Specification text	AR - 12
	Attachments - Dampers	AR - 14

Description

Application

- Ventilation grille of Type AR as extract air variant for comfort zones and industrial zones
- Blades at a fixed angle to block view
- For variable and constant volume flows
- For installation in walls, ceilings and rectangular ducts

Variants

Front Border

- AR: 32 mm wide

Fixing

- 0: Countersunk holes
- X: Without holes (border drilling by customer)

Parts and characteristics

- Angled front border with chamfered inside edge
- Fixed horizontal blades
- Factory fitted perimeter seal

Nominal sizes

- Nominal length: 150mm up to 1200mm (50mm increments)
 - Nominal height: 100mm up to 600mm (50mm increments)
- Intermediate sizes upon request

Attachments

- AG: For volume flow control

Special characteristics

- Fixed blades
- Angled front border
- Countersunk holes

Construction features

- 32 mm wide border
- Fixed angle horizontal blades

Materials and surfaces

- Border and blades made of aluminium
- P3: Border and blades powder-coated, RAL9010:20%
- P6: Powder-coated RAL CLASSIC colour. Gloss level: 25%

Installation and commissioning

- Installation preferably in walls, ceilings and rectangular ducts
- Ideally the border should be fixed with screws

Standards and guidelines

- Sound power level of the air-regenerated noise measured according to EN ISO 5135

Maintenance

- Maintenance-free as construction and materials are not subject to wear
- Inspection and cleaning to VDI 6022

Technical data

Nominal sizes	150 × 100 to 1200 × 600 mm
Maximum volume flow rate, with L_{WA} max. 40 dB(A) without attachments	1202 l/s or 4327 m ³ /h

Volume flow rates for single grille for extract air.

Extract Air

Effective inlet area

H	L [mm]							
	150	200	300	400	500	600	700	800
	A_{eff}							
mm	m^2							
100	0.002	0.003	0.006	0.008	0.010	0.012	0.014	0.016
150	0.004	0.006	0.010	0.014	0.017	0.021	0.025	0.029
200		0.009	0.014	0.019	0.025	0.031	0.035	0.041
250			0.019	0.025	0.032	0.040	0.046	0.053
300			0.023	0.031	0.040	0.049	0.057	0.066
350				0.037	0.048	0.058	0.068	0.078
400				0.043	0.055	0.067	0.078	0.091
450					0.063	0.077	0.089	0.103
500					0.070	0.086	0.100	0.115
550						0.095	0.114	0.128
600						0.104	0.127	0.140

H	L [mm]			
	900	1000	1100	1200
	A_{eff}			
mm	m^2			
100	0.018	0.020	0.022	0.024
150	0.033	0.036	0.040	0.044
200	0.047	0.051	0.057	0.063
250	0.060	0.067	0.074	0.081
300	0.072	0.083	0.092	0.101
350	0.089	0.098	0.109	0.119
400	0.103	0.113	0.126	0.142
450	0.117	0.130	0.143	0.158
500	0.131	0.145	0.160	0.176
550	0.145	0.161	0.178	0.195
600	0.159	0.176	0.195	0.214

Principal dimensions

L [mm]

Nominal length of the ventilation grille

m [kg]

Weight

H [mm]

Nominal height of the ventilation grille

Nomenclature

L_{WA} [dB(A)]

Sound power level of the air-regenerated noise

Δp_t [Pa]

Total differential pressure

\dot{V} [m³/h] and [l/s]

Volume flow rate

Ventilation grilles for installation into walls, ceilings or rectangular ducts

Quick sizing

Sizing with the help of this catalogue

This catalogue provides convenient quick sizing tables for ventilation grilles. The volume flow rates apply to a nominal grille length [L] of 1000mm, maximum sound power level of the air-regenerated noise of 40 dB(A) with an open damper unit (unrestricted airflow) and maximum 20 Pa pressure drop.

Technical data

The table gives extract air volume flow rates, based on l/s/m for a maximum 5Pa, 10Pa, 15Pa or 20Pa limit.

Maximum sound power level of the air-regenerated noise of 40 dB(A) with an open damper unit (unrestricted airflow)

Extract Air

Extract Air Volume				
Δp_t (Pa)	5	10	15	20
H (mm)	V (l/s/m)			
100	63	90	111	129
150	106	151	185	215
200	148	211	260	301
250	198	283	348	403
300	244	347	427	495
350	294	419	515	597
400	342	487	599	694
450	401	570	702	813
500	445	634	780	904
550	509	725	891	1033
600	551	785	966	1119

Single grille

AR as a single grille

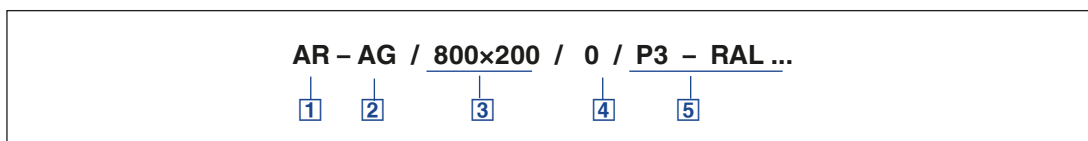

1 Type

AR Single grille (32mm border)

2 Attachments

A Grille face only

AG Damper unit with opposed action blades*

3 Nominal size [mm]

L × H

4 Fixing

0 Countersunk holes (30mm border)
X Without holes¹⁾

5 Exposed surface

P3 RAL 9010:20%

P6 Powder-coated RAL CLASSIC colour.
Gloss level: 25%

* Damper assembly to be specified within plenum box (when supplied)

¹⁾Not in conjunction with AG attachment

Order example

AR-AG/800x200/0/P3/RAL9010/20% Gloss

Attachments	Damper unit, opposed action blades
Nominal size	800 × 200 mm
Fixing	Screwfix border
Exposed surface	Powdercoat, RAL9010:20% (white)

Plenum box

AK-AR, plenum box

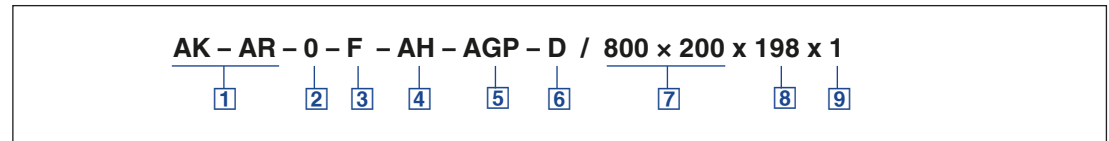

1 Type

AK-AR Plenum box to suit AR grille

2 Grille fixing

0 Countersunk holes (32mm border)
X Without holes

3 Plenum style

F Finite
M Linear

4 Connection type

AH Horizontal (extract air)
AV Vertical (extract air)

5 Damper type

0 Without damper
M Perforated spigot damper
MC Cord operated spigot damper
AGP Opposed blade VCD (fitted to plenum)¹⁾

6 Internal lining

0 No lining
D 12mm foam lining

7 Plenum nominal size [mm]

L x H

8 Spigot size [mm]

Ø98, Ø123, Ø138, Ø148, Ø158, Ø178,
Ø198, Ø222, Ø248, Ø278, Ø298, Ø313,
Ø348, Ø353, Ø398, Ø448*, Ø498*, Ø558*
Not in combination with ...-M, ...-MC

9 Spigot quantity

Qty 1...4

¹⁾ Damper assembly to be specified within plenum box (when supplied)

Order example

AK-AR-0-F-AH-AGP-D/800x200x198x1

Grille fixing	Counterpunch border
Plenum style	Finite
Connection type	Horizontal (extract air)
Damper type	Opposed blade VCD (fitted to plenum)
Plenum lining	12mm foam lining
Plenum nominal size	800mm x 200mm
Spigot size	Ø198mm
Spigot quantity	1

Front border and blade

Front border AR-...-0

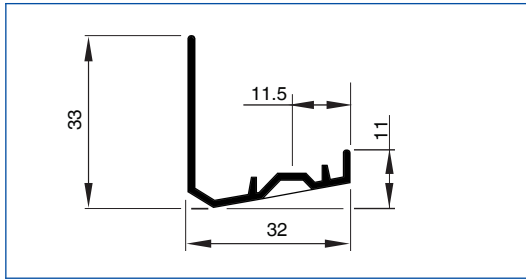

Front border AR-...-X

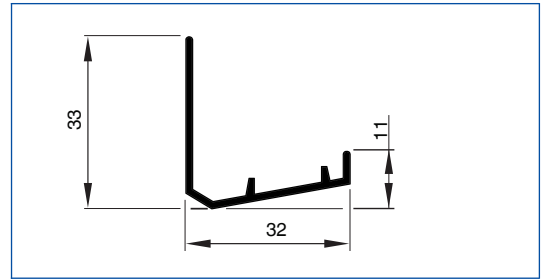

Blade gap

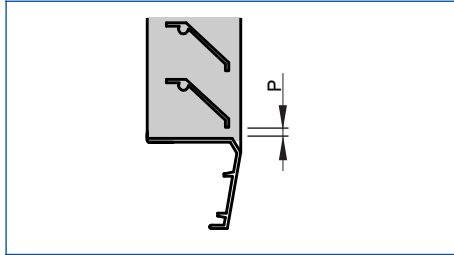

Nominal height: 100, 200, 300, 400, 500, 600	P = 4 mm
Nominal height: 150, 250, 350, 450, 550	P = 14 mm

Single grille

AR, 32 mm wide front border

L: Nominal length
H: Nominal height

Cut out size;
Grille fixing ...-0, ...-X

H / L

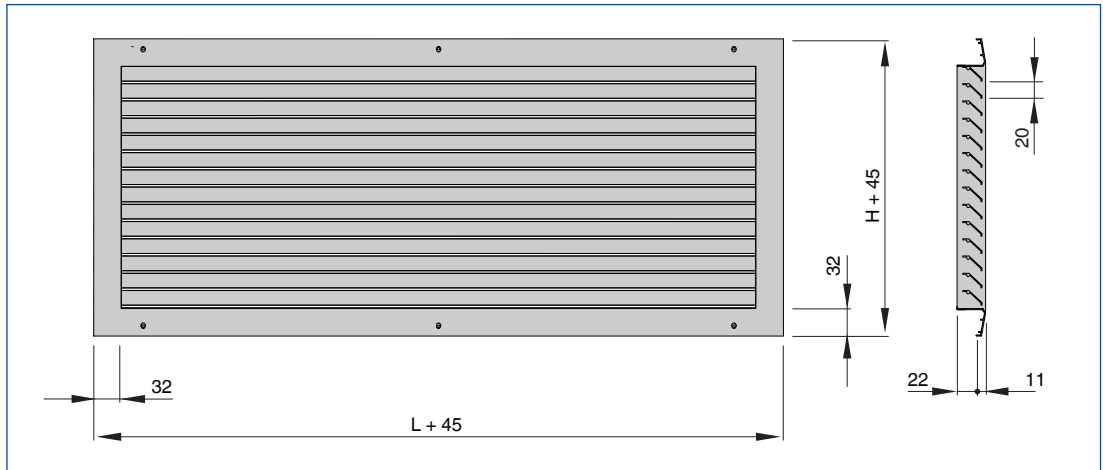

Weights

H	Single Grille
	m
mm	kg/m
100	1.6
150	1.9
200	2.2
250	2.4
300	2.7
350	3.0

H	Single Grille
	m
mm	kg/m
400	3.3
450	3.6
500	3.9
550	4.1
600	4.5

Weights apply to sections without attachments

Border punch detail

AR, 32 mm wide front border

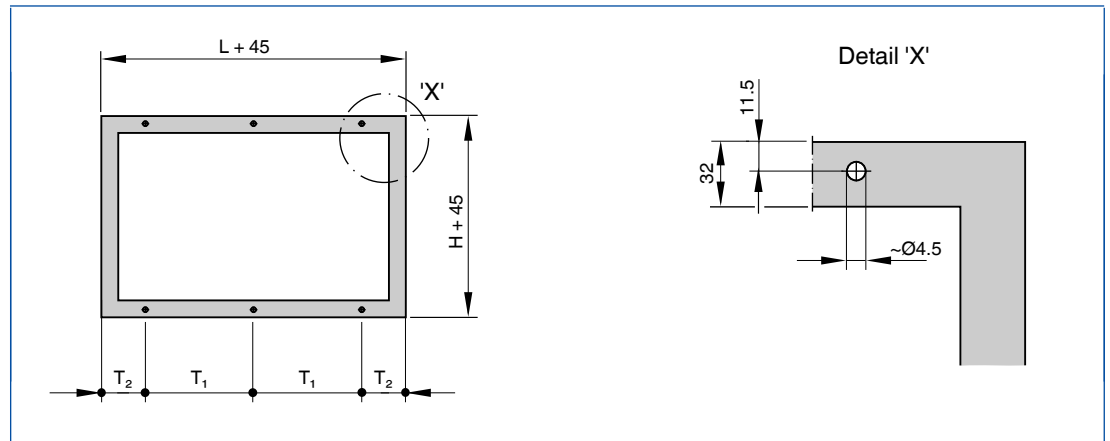

AR, standard sizes, width, no. of border fixing holes

Length L mm	No. of holes n	mm	
		T ₁	T ₂
150	1	-	97.5
200	1	-	122.5
250	2	159.0	68
300	2	209.0	68
350	2	259.0	68
400	2	309.0	68
450	2	359.0	68
500	2	409.0	68
550	3	229.5	68
600	3	254.5	68
650	3	279.5	68
700	3	304.5	68
750	3	329.5	68
800	3	354.5	68
850	4	253.0	68
900	4	269.7	68
950	4	286.3	68
1000	4	303.0	68
1050	4	319.7	68
1100	4	336.3	68
1150	4	353.0	68
1200	4	369.7	68

Fixing of ventilation grilles

Ventilation grille with screw fixing

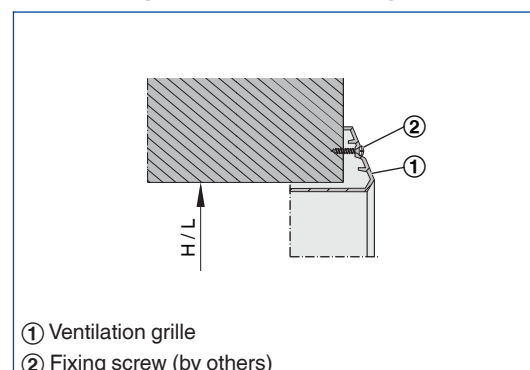

Plenum Box AK-AR Connection type ...-AH

NOTE;
Hanging brackets only supplied where $L_1 > 300\text{mm}$

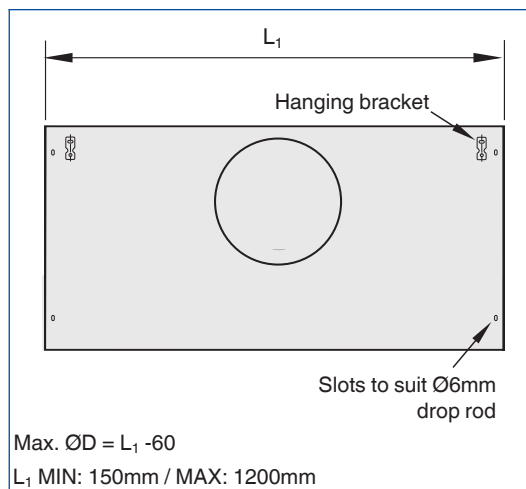
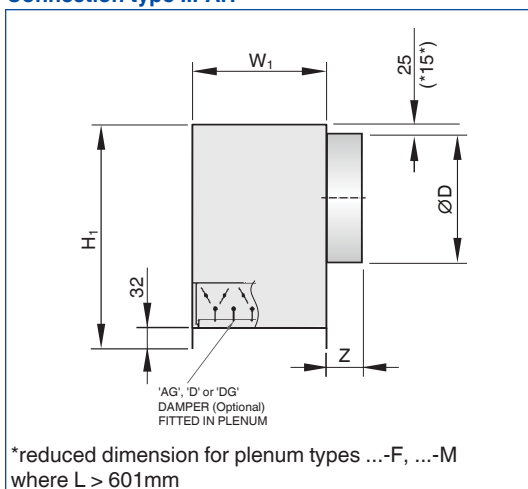

Connection type...-AV [$\text{ØD} < H - 27$]

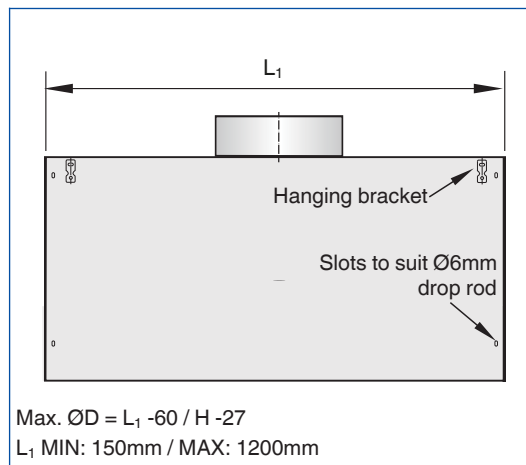
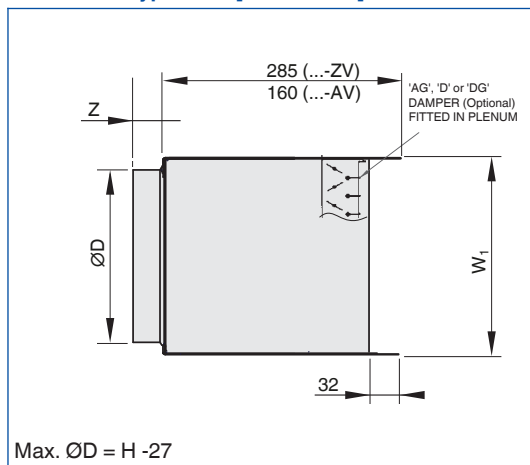

Connection type...-AV [$\text{ØD} > H - 27$]

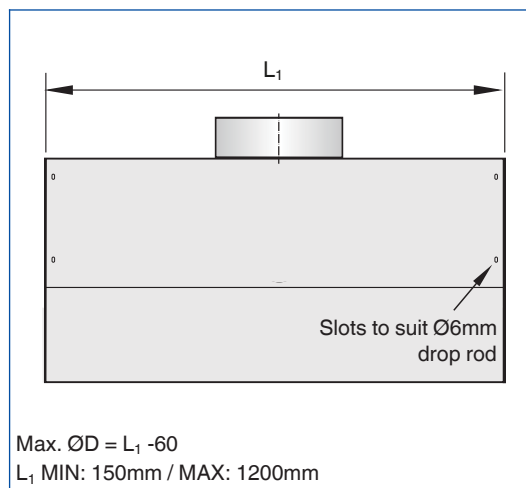
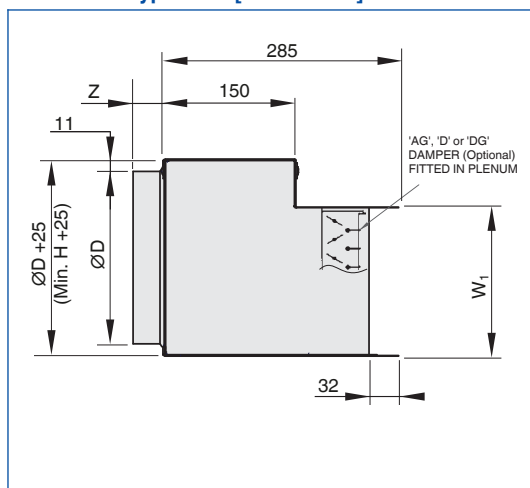

Dimensions

H_1 dimension excludes grille border

Overall plenum & grille assembled height;
 H_1 + grille border depth

Grille Fixing	Dimensions					
	Plenum Type	L_1	H_1	ØD1	W_1	Z
...-O	F / M	L - 5	$\text{ØD} + 150$	L / H - 30	H - 5	40 (*75)
...-X	F	L - 12	$\text{ØD} + 150$	L / H - 40	H - 12	40 (*75)
	M	L - 5	$\text{ØD} + 150$	H - 40	H - 12	40 (*75)

Spigot Z
...-O (without spigot damper): 40mm
...-M / ...-MC : 75mm

Plenum type F: Finite (nominal plenum length = nominal grille length)
M: Linear (nominal plenum length < nominal grille length)

Multi Spigot

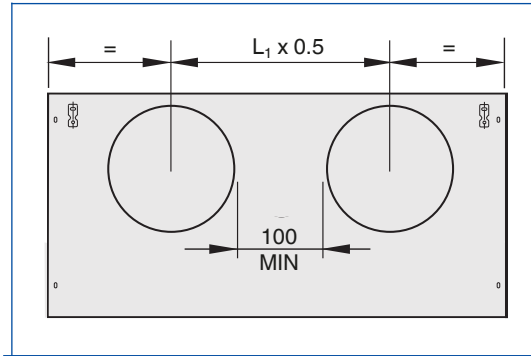

MAX. ØD = $[(L_1 - 60) / \text{Spigot qty}] - 100$

Spigot location equally spaced for side & top entry plenum boxes.

Standard text

This specification text describes the general properties of the product.

Ventilation grilles, rectangular, made of aluminium, for supply and extract air. Rectangular profile border. Preferably for wall and ceiling installation but also suitable for rectangular ducts. Ready-to-install component which consists of a border and fixed horizontal blades. Countersunk holes for fixing onto an installation surface. Sound power level of the air-regenerated noise measured according to EN ISO 5135.

Technical data

- Nominal sizes: 150 × 100 to 1200 × 600 mm
- Maximum volume flow rate (extract air):
1202 l/s or 4327 m³/h
at L_{WA} max. 40 dB(A) without attachments

Special characteristics

- Fixed blades
- Front border
- Countersunk holes

Sizing data

- \dot{V} _____ [l/s]
- Δp_t _____ [Pa]
- L_{WA} Air-regenerated noise _____ [dB(A)]

Materials and surfaces

- Border and blades made of aluminium
- P3 : Border and blades powder-coat RAL9010:20%
- P6: Powder-coated RAL CLASSIC colour.
Gloss level: 25%

Order options

AR as a single grille

AR – AG / 800x200 / 0 / P3 – RAL ...				
1	2	3	4	5

1 Type

AR Single grille (32mm border)

2 Attachments

A Grille face only

AG Damper unit with opposed action blades¹⁾

3 Nominal size [mm]

L × H

4 Fixing

0 Countersunk holes (32mm border)

X Without holes*

5 Exposed surface

P3 RAL 9010:20%

P6 Powder-coated RAL CLASSIC colour.
Gloss level: 25%

¹⁾Damper assembly to be specified within plenum box (when supplied)

* Not in conjunction with AG attachment

Plenum box

AK-AR, plenum box

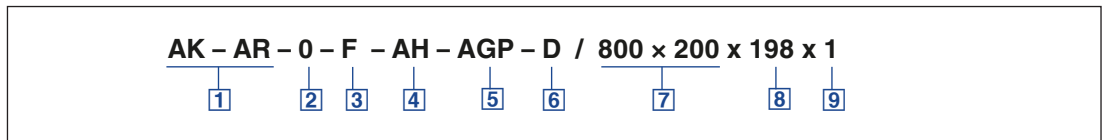

1 Type

AK-AR Plenum box to suit AR grille

2 Grille fixing

0 Countersunk holes (32mm border)
X Without holes

3 Plenum style

F Finite
M Linear

4 Connection type

AH Horizontal (extract air)
AV Vertical (extract air)

5 Damper type

0 Without damper
M Perforated spigot damper
MC Cord operated spigot damper
AGP Opposed blade VCD (fitted to plenum)¹⁾

6 Internal lining

0 No lining
D 12mm foam lining

7 Plenum nominal size [mm]

L × H

8 Spigot size [mm]

Ø98, Ø123, Ø138, Ø148, Ø158, Ø178,
 Ø198, Ø222, Ø248, Ø278, Ø298, Ø313,
 Ø348, Ø353, Ø398, Ø448*, Ø498*, Ø558*
 Not in combination with ...-M, ...-MC

9 Spigot quantity

Qty 1...4

¹⁾Damper assembly to be specified within plenum box (when supplied)

Attachments

Types -AG



AG

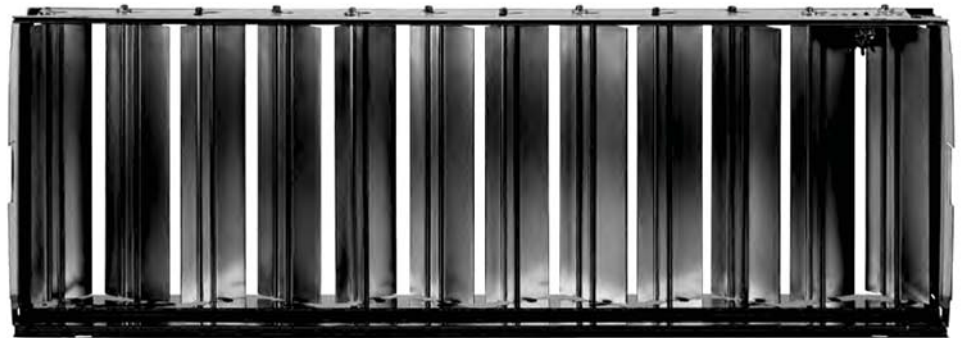

Attachments for ventilation grilles, made of sheet steel, for volume flow rate balancing and air direction control

Attachments with manually adjustable blades

- Volume flow rate balancing
- Air direction control

Type		Page
-AG	General information	AR – 15
	Special information – -AG	AR – 16

Description

Application

- Attachments for ventilation grilles offer additional functions
- For volume flow rate balancing and/or for air direction control
- Damper units simplify the volume flow rate balancing required for commissioning, for supply air and extract air
- Ventilation grille need not be removed for adjustment

Variants

- AG: Damper unit with opposed action blades

Maintenance

- Maintenance-free as construction and materials are not subject to wear
- Inspection and cleaning to VDI 6022

Any accessories are defined with the order code of the ventilation grille.

Attachments for ventilation grilles

Type of ventilation grille	Attachment		
	-AG	-D	-DG
	Damper unit	Air direction control	Damper unit Air direction control
Installation into walls, ceilings or rectangular ducts			
AT	●	●	●
VAT	●	●	●
AH	●	●	●
AHR	●	●	●
WAP	●	●	●
WAPR	●	●	●
AF	●	●	●
AFW	●	●	●
AFH	●	●	●
AR	●		

Description

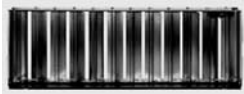

AG



Order code detail

Application

- For volume flow rate balancing
- Damper units simplify the volume flow rate balancing required for commissioning, for supply air and extract air
- Ventilation grille need not be removed for adjustment

Parts and characteristics

- Opposed action blades
- Can be adjusted and set with screws

Function

Schematic illustration of -AG

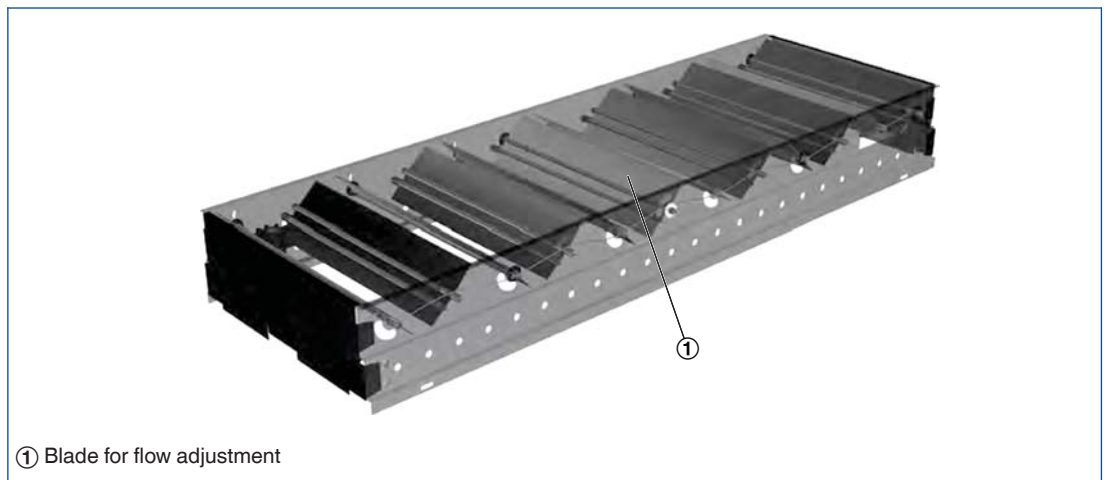

Commissioning

Volume flow rate balancing -*G

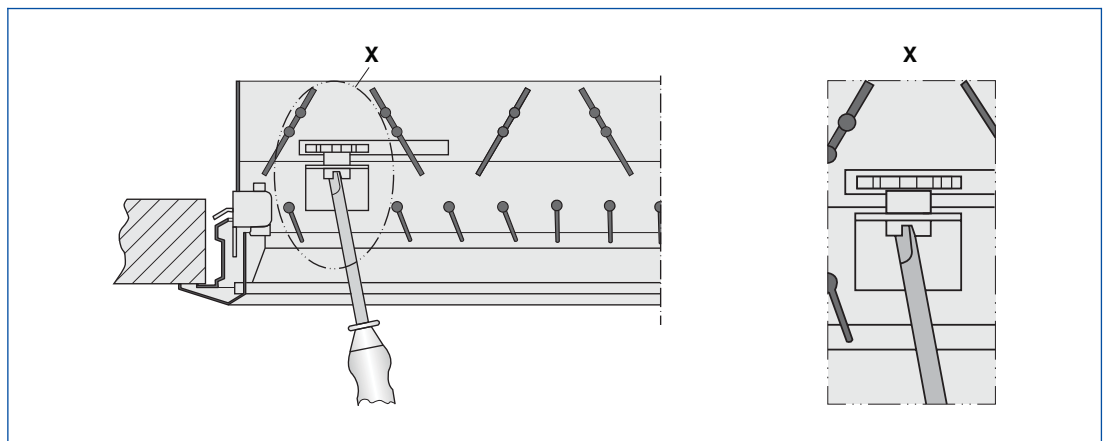

Attachments -AG

-AG

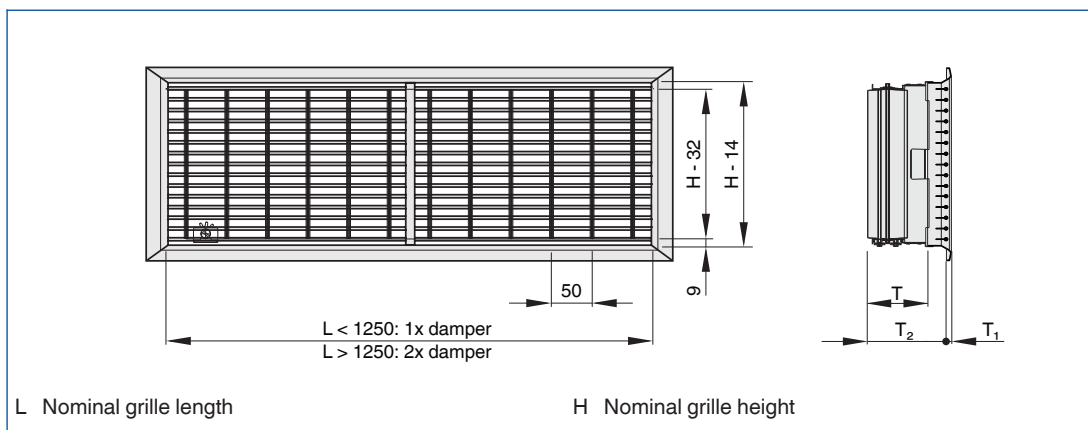

Dimensions

Product type	T	T ₁	T ₂
	mm		
AT	70	11	92
VAT	70	11	92
AH	70	8	92
AHR	70	8	92
WAP	70	8	92
WAPR	70	8	92
AF	70	0	123
AFH	70	0	123
AFW	70	0	123
AR	70	11	92