

Waterside Fancoil Units

Type PWX



Horizontal chassis type waterside fancoils for concealed or exposed installations

Waterside fancoil units for cooling, heating and fresh air supply applications

- Nominal sizes 60, 90, 120, 150, 180 & 205
- Volume flow rate range 50 – 636 l/s or 180 – 2289 m³/h
- Casing manufactured with 1.2mm galvanised steel, natural finish
- Condensate drip tray made of galvanised steel with powder-coat finish
- Heat exchanger for cooling (2-pipe) or cooling and heating (4-pipe) systems
- Easy filter change, no tools required
- Access hatch with integrated hinge
- Acoustically optimised EC/DC fans with low specific fan powers and variable supply air volume control (0-10v signal required)

Optional equipment and accessories

- Integrated controls package
- Inlet attenuator
- Discharge attenuator
- Inlet plenum
- Electric heating
- Circular or rectangular discharge connection

Type		Page
PWX	General information	PD – PWX – 2
	Quick sizing	PD – PWX – 4
	Acoustic qualification	PD – PWX – 6
	Order code	PD – PWX – 7
	Dimensions and weights	PD – PWX – 8
	Electrical data	PD – PWX – 10
	Electric heating	PD – PWX – 11
	Controls	PD – PWX – 12
	Specification text	PD – PWX – 19
	Accessories (Inlet / Discharge attenuators)	PD – PWX – 21
	General information	PD – PWX – 22
	Dimensions and weights	PD – PWX – 23
	Order code	PD – PWX – 27
	Installation	PD – PWX – 28
	Accessories (Inlet plenum)	PD – PWX – 29
	General information	PD – PWX – 30
	Dimensions and weights	PD – PWX – 31
	Order code	PD – PWX – 32
	Installation	PD – PWX – 33

Installation example

Concealed installation



Description

Application

- Waterside fancoil Type PWX designed to provide cooling and heating for comfort and industrial applications
- Acoustically optimised EC/DC fans with low specific fan powers and adjustable supply air volume control (0-10v signal)
- Acoustically lined inlet and discharge plenums provide low sound power levels and improved thermal insulation
- 2-pipe or 4-pipe heat exchangers enable high comfort levels
- For horizontal installation in ceiling voids, floor voids or exposed applications

Variants

- F7: Individual pod fans (single fan per motor)
- F10: Deck fans (2 or 3 fans per motor)

Parts and characteristics

- Heat exchanger as 2-pipe or 4-pipe system with Ø15mm or Ø22mm OD plain copper tails
- 200mm wide condensate drip tray with Ø15mm OD drain connection
- EU2/G2 fabric inlet filter
- Ø200mm, Ø250mm or rectangular discharge connections

Nominal sizes

- PWX-60: 600 x 900 x 270 mm (W x L x H)
- PWX-90: 900 x 900 x 270 mm (W x L x H)
- PWX-120: 1200 x 900 x 270 mm (W x L x H)
- PWX-150: 1500 x 900 x 270 mm (W x L x H)
- PWX-180: 1800 x 900 x 270 mm (W x L x H)
- PWX-205: 2050 x 900 x 270 mm (W x L x H)

Attachments

- Controls enclosure

Accessories

- Inlet attenuator for noise critical applications
- Inlet plenum for ducted return air applications
- Discharge attenuator

Special characteristics

- Removable access hatch with integrated hinge to facilitate inspection and maintenance
- Independent fan mounting enables individual removal or replacement
- Fire resistant 'Class O' acoustic insulation provides low operating noise levels and improved thermal isolation

Construction features

Casing

- PWX casing manufactured from 1.2mm galvanised steel. Manufacturing process provides rigid, vibration free design with integrated supporting flanges

Access hatch

- Access hatch manufactured from 1.2mm galvanised steel.
- Integrated hinge mechanism enables the panel to swing down without removal
- High density mesh-enforced gasket seal

Condensate drip tray

- Condensate drip tray manufactured from 1.2mm galvanised steel with powder-coat finish, RAL 9005 (black)
- Unique, 2-way sloping design ensures effective removal of condensate along the full length of the tray
- Extended width design of 200mm as standard provides condensate cover for pre-installed valve assemblies
- Externally insulated with 3mm, fire resistant 'Class O' closed cell insulation

Acoustic insulation

- Fire resistant 'Class O' acoustic insulation tested to BS476 Parts 6 & 7
- Low thermal conductivity of 0.036 W/m.K provides improved thermal resistance

Heat exchanger

- Heat exchangers manufactured from seamless Ø3/8" copper tube, expanded on to profiled aluminium fins
- All heat exchangers tested to 30 bar
- Max. test pressure for factory fitted control valves: 10 bar
- Key operated vents and drains incorporated within header block
- 4-pipe coil assembly provides optimised cooling & heating control
- 2-pipe coil assembly provides optimised cooling control. Can be used in conjunction with electric heating

Controls enclosure

- Controls enclosure manufactured from 1.0mm galvanised steel
- Constructed in accordance with BS 7671, IET wiring regulations
- Top cover to IP4X, all other surfaces to IP2X
- Enclosure mechanically fixed to PWX casing using pre-formed backplate
- Removable lid provides access to installed controls
- Supply voltage: 230 V AC + / - 10%, 50/60 Hz

Inlet plenum

- Inlet plenum manufactured from 1.2mm galvanised steel
- Fire resistant 'Class O' acoustic insulation applied to internal surfaces
- Ø198mm or Ø248mm spigots
- Installation bracket for quick-coupling to PWX fancoil on site

Inlet attenuator

- Inlet attenuator manufactured from 1.2mm galvanised steel
- Fire rated 'Class A1' mineral wool acoustic lining
- Installation bracket for quick-coupling to PWX fancoil on site

Discharge attenuator

- Discharge attenuator manufactured from 1.2mm galvanised steel
- Fire rated 'Class A1' mineral wool acoustic lining
- Installation bracket for quick-coupling to PWX fancoil on site

Inlet filter

- S: Fabric filter, EU2/G2
- S3: Fabric filter, EU3/G3
- F: Washable foam filter, Class O, EU2/G2
- M: Washable mesh screen, stainless steel

Quick sizing

The quick sizing tables contained within this datasheet provide reference outputs for Type PWX under typical design conditions.

For specific enquires relating to project specific performance, please contact your TROX representative.

Quick sizing performance criteria;

Air entering temperature (cooling):.....23°C
 Air entering temperature (heating):21°C
 Relative humidity:..... 50%
 CHW flow / return:.....6°C / 12°C
 LTHW flow / return:.....80°C / 60°C
 External static pressure:.....30 Pa

Guide NR: 30

Fan type: F7

Model	Airside		Cooling				Heating			SFP
	FCU Supply Volume		Total	Sens.	Water flow	Water ΔPt	Total	Water flow	Water ΔPt	
	(l/s)	(m ³ /hr)								
PWX-60/1	80	288	1.35	1.12	0.054	6.1	1.63	0.022	0.8	0.17
PWX-90/1	120	432	2.10	1.74	0.084	6.4	2.77	0.037	2.7	0.18
PWX-90/2	136	490	2.35	1.95	0.094	7.9	3.01	0.040	3.1	0.17
PWX-120/2	192	691	3.32	2.75	0.132	9.1	3.89	0.052	1.1	0.16
PWX-120/3	189	680	3.26	2.70	0.130	8.9	3.84	0.051	1.1	0.15
PWX-150/3	215	774	3.76	3.11	0.150	6.3	4.73	0.063	1.9	0.16
PWX-180/3	283	1019	4.91	4.06	0.195	7.4	6.23	0.083	3.5	0.17
PWX-180/4	289	1040	5.00	4.15	0.199	7.6	6.33	0.084	3.6	0.16
PWX-205/4	319	1148	5.51	4.57	0.220	7.0	7.20	0.096	5.0	0.16

Fan type: F10

Model	Airside		Cooling				Heating			SFP
	FCU Supply Volume		Total	Sens.	Water flow	Water ΔPt	Total	Water flow	Water ΔPt	
	(l/s)	(m ³ /hr)								
PWX-60/1	-	-	-	-	-	-	-	-	-	-
PWX-90/1	-	-	-	-	-	-	-	-	-	-
PWX-90/2	176	634	2.95	2.44	0.117	11.7	3.57	0.047	4.2	0.18
PWX-120/2	252	907	4.20	3.48	0.167	13.9	4.65	0.062	1.6	0.20
PWX-120/3	304	1094	4.91	4.06	0.195	18.2	5.23	0.069	1.9	0.18
PWX-150/3	336	1210	5.55	4.60	0.221	12.6	6.34	0.084	3.2	0.19
PWX-180/3	335	1206	5.69	4.71	0.227	9.6	6.97	0.093	4.3	0.19
PWX-180/4	379	1364	6.33	5.25	0.252	11.5	7.56	0.100	5.0	0.19
PWX-205/4	414	1490	6.91	5.73	0.275	10.5	8.53	0.113	6.8	0.18

Guide NR: 35

Fan type: F7

Model	Airside		Cooling				Heating			SFP
	FCU Supply Volume		Total	Sens.	Water flow	Water ΔPt	Total	Water flow	Water ΔPt	
	(l/s)	(m ³ /hr)								
PWX-60/1	127	457	2.02	1.67	0.080	12.4	2.20	0.029	1.3	0.19
PWX-90/1	158	568	2.68	2.22	0.107	10.0	3.32	0.044	3.7	0.23
PWX-90/2	213	767	3.46	2.87	0.138	15.7	4.03	0.053	5.2	0.19
PWX-120/2	284	1022	4.64	3.85	0.185	16.6	5.01	0.067	1.8	0.21
PWX-120/3	321	1156	5.14	4.26	0.205	19.8	5.41	0.072	2.1	0.20
PWX-150/3	351	1264	5.76	4.77	0.230	13.6	6.53	0.087	3.3	0.19
PWX-180/3	397	1429	6.58	5.45	0.262	12.3	7.77	0.103	5.2	0.21
PWX-180/4	441	1588	7.19	5.96	0.287	14.3	8.32	0.110	5.9	0.19
PWX-205/4	476	1714	7.79	6.45	0.310	13.1	9.34	0.124	8.0	0.20

Fan type: F10

Model	Airside		Cooling				Heating			SFP
	FCU Supply Volume		Total	Sens.	Water flow	Water ΔPt	Total	Water flow	Water ΔPt	
	(l/s)	(m ³ /hr)	(kW)	(kW)	(kg/s)	(kPa)	(kW)	(kg/s)	(kPa)	
PWX-60/1	-	-	-	-	-	-	-	-	-	-
PWX-90/1	-	-	-	-	-	-	-	-	-	-
PWX-90/2	242	871	3.85	3.19	0.153	18.8	4.36	0.058	6.0	0.21
PWX-120/2	309	1112	4.98	4.12	0.198	18.7	5.28	0.070	2.0	0.24
PWX-120/3	375	1350	5.83	4.83	0.232	24.4	5.94	0.079	2.4	0.22
PWX-150/3	411	1480	6.57	5.44	0.262	17.1	7.20	0.096	4.0	0.23
PWX-180/3	431	1552	7.06	5.85	0.281	13.8	8.21	0.109	5.8	0.25
PWX-180/4	502	1807	8.02	6.64	0.319	16.9	9.03	0.120	6.8	0.23
PWX-205/4	525	1890	8.46	7.01	0.337	15.2	9.94	0.132	8.9	0.21

Guide NR: 40

Fan type: F7

Model	Airside		Cooling				Heating			SFP
	FCU Supply Volume		Total	Sens.	Water flow	Water ΔPt	Total	Water flow	Water ΔPt	
	(l/s)	(m ³ /hr)	(kW)	(kW)	(kg/s)	(kPa)	(kW)	(kg/s)	(kPa)	
PWX-60/1	169	608	2.56	2.12	0.102	19.3	2.63	0.035	1.8	0.26
PWX-90/1	191	688	3.15	2.61	0.126	13.4	3.75	0.050	4.6	0.30
PWX-90/2	283	1019	4.38	3.63	0.174	23.3	4.79	0.064	7.0	0.24
PWX-120/2	360	1296	5.64	4.67	0.225	23.2	5.80	0.077	2.3	0.28
PWX-120/3	431	1552	6.50	5.38	0.259	29.2	6.42	0.085	2.8	0.25
PWX-150/3	464	1670	7.25	6.00	0.289	20.4	7.75	0.103	4.5	0.24
PWX-180/3	493	1775	7.89	6.54	0.314	16.5	8.92	0.118	6.7	0.27
PWX-180/4	574	2066	8.93	7.40	0.356	20.0	9.78	0.130	7.8	0.25
PWX-205/4	621	2236	9.71	8.04	0.387	19.5	11.01	0.146	10.7	0.26

Fan type: F10

Model	Airside		Cooling				Heating			SFP
	FCU Supply Volume		Total	Sens.	Water flow	Water ΔPt	Total	Water flow	Water ΔPt	
	(l/s)	(m ³ /hr)	(kW)	(kW)	(kg/s)	(kPa)	(kW)	(kg/s)	(kPa)	
PWX-60/1	-	-	-	-	-	-	-	-	-	-
PWX-90/1	-	-	-	-	-	-	-	-	-	-
PWX-90/2	305	1098	4.63	3.84	0.185	25.8	4.99	0.066	7.5	0.27
PWX-120/2	362	1303	5.67	4.69	0.226	23.4	5.82	0.077	2.3	0.29
PWX-120/3	441	1588	6.62	5.49	0.264	30.1	6.50	0.086	2.8	0.28
PWX-150/3	481	1732	7.46	6.18	0.297	21.4	7.91	0.105	4.7	0.28
PWX-180/3	526	1894	8.32	6.89	0.331	17.9	9.28	0.123	7.1	0.33
PWX-180/4	623	2243	9.53	7.89	0.379	21.8	10.24	0.136	8.5	0.28
PWX-205/4	632	2275	9.85	8.16	0.392	19.9	11.13	0.148	10.9	0.26

Room NR Guide

Acoustic correction factors

NR guide values detailed within this data sheet and TROX PWX selection tool are calculated using logarithmic addition of inlet/ case radiated and discharge sound power levels, measured at an independent acoustic facility in accordance with BS EN 16583:2015

NR guides should be used for reference only and are subject to room correction factors, based on a typical installation.

Sound power level spectral data can be provided on request to allow project specific evaluation.

Room correction factors ...-20A, ...-25A

Room correction	SPL frequency corrections							
	63	125	250	500	1K	2K	4K	8K
Ceiling tile SRI	-6	-4	-7	-10	-12	-12	-13	-8
Reverb time [$<0.7s$]	-2	-2	-2	-2	-2	-2	-2	-2
Directivity	9	9	9	9	9	9	9	9
Distance to listener [1.5m]	-14	-14	-14	-14	-14	-14	-14	-14
Room volume;								
PWX-60	-3	-3	-3	-3	-3	-3	-3	-3
PWX-90	-4	-4	-4	-4	-4	-4	-4	-4
PWX-120	-7	-7	-7	-7	-7	-7	-7	-7
PWX-150	-7	-7	-7	-7	-7	-7	-7	-7
PWX-180	-8	-8	-8	-8	-8	-8	-8	-8
PWX-205	-8	-8	-8	-8	-8	-8	-8	-8
% of sound leaving outlet								
PWX-60	-3	-3	-3	-3	-3	-3	-3	-3
PWX-90	-3	-3	-3	-3	-3	-3	-3	-3
PWX-120	-5	-5	-5	-5	-5	-5	-5	-5
PWX-150	-6	-6	-6	-6	-6	-6	-6	-6
PWX-180	-6	-6	-6	-6	-6	-6	-6	-6
PWX-205	-7	-7	-7	-7	-7	-7	-7	-7
1m Acoustic flex	-4	-5	-6	-8	-9	-9	-7	-8
End reflection correction								
20A [$\varnothing 198mm$ spigots]	-16	-10	-5	-2	-1	0	0	0
25A [$\varnothing 248mm$ spigots]	-14	-9	-4	-1	0	0	0	0

Room correction factors ...-20R

Room correction	SPL frequency corrections							
	63	125	250	500	1K	2K	4K	8K
Ceiling tile SRI	-6	-4	-7	-10	-12	-12	-13	-8
Reverb time [$<0.7s$]	-2	-2	-2	-2	-2	-2	-2	-2
Directivity	9	9	9	9	9	9	9	9
Distance to listener [1.5m]	-14	-14	-14	-14	-14	-14	-14	-14
Room volume;								
PWX-60	-3	-3	-3	-3	-3	-3	-3	-3
PWX-90	-4	-4	-4	-4	-4	-4	-4	-4
PWX-120	-7	-7	-7	-7	-7	-7	-7	-7
PWX-150	-7	-7	-7	-7	-7	-7	-7	-7
PWX-180	-8	-8	-8	-8	-8	-8	-8	-8
PWX-205	-8	-8	-8	-8	-8	-8	-8	-8
% of sound leaving outlet								
PWX-60, 90	0	0	0	0	0	0	0	0
PWX-120, 150	-3	-3	-3	-3	-3	-3	-3	-3
PWX-180, 205	-5	-5	-5	-5	-5	-5	-5	-5
End reflection correction								
20R [Rect.] PWX-60	-11	-6	-2	-1	0	0	0	0
PWX-90	-9	-5	-2	-1	0	0	0	0
PWX-120	-8	-4	-1	0	0	0	0	0
PWX-150	-7	-3	-1	0	0	0	0	0
PWX-180	-7	-3	-1	0	0	0	0	0
PWX-205	-6	-3	-1	0	0	0	0	0

Order code

PWX

PWX	-	90/2	-	F7	-	R	-	4	-	2	-	T15	-	25A	-	23	-	S	-	1	-	P2	-	1	-	0
1		2		3		4		5		6		7		8		9		10		11		12		13		14

1 Unit type

PWX

2 Unit size

60/1, 90/1, 90/2, 120/2, 120/3, 150/3, 180/3, 180/4, 205/4

3 Fan type

F7 Pod fans (1 fan per motor)
F10 Deck fans (Up to 3 fans per motor)

4 Unit handing

L Left hand controls
R Right hand controls

5 Heat exchanger type

4 3½ row cooling + ½ row heating
2 4 row cooling
E2 4 row cooling + electric heating
E4 3½ row cooling + electric heating

6 Valve package

0 Without valves
1 Cooling only
2 Cooling & heating (coil type 4 only)
3 Heating only (coil type 4 only)
F1 Factory-fit free issue cooling valve
F2 Factory-fit free issue cooling & heating
F3 Factory-fit free issue heating valve

7 Condensate tray

T15 Epoxy painted galvanized tray with horizontal end outlet (Ø15mm)
T15E Extended T15 (+100mm) (PWX 60-180 only)

8 Discharge outlet type

20A Ø198 spigots
25A Ø248 spigots
20R 198mm rectangular spigot

9 Active Spigots

PWX-60 A,2,3,B
PWX-90 A,2,3,B
PWX-120 A,2,3,4,B
PWX-150 A,2,3,4,5,B
PWX-180 A,2,3,4,5,B
PWX-205 A,2,3,4,5,6,B

10 Inlet filter

S Standard (fabric) EU2/G2
S3 Fabric EU3/G3
M Mesh screen (S/steel)
F Foam EU2/G2 `Class 0`

11 Accessory fixing

0 Standard
1 Inlet accessory fittings
2 Discharge accessory fittings
3 Inlet & discharge accessory fittings

12 Condensate pump

0 Without
P1 Condensate pump, supplied loose for installation, wiring & commissioning (by others)
P2 Condensate pump, supplied loose for installation, wiring & commissioning (by others). Pump power cable prewired to controls enclosure.

13 Controls

0 Controls enclosure with provision for site fitted controls
1 BACnet controls
2 Room control (standalone)
F Factory-fit free issue controls

14 Packaging

0 Standard (batch wrapped)
A Individually wrapped (shrink wrap)
B Active spigots capped (batch wrapped)

Order example

PWX-90/2-F7-R-4-2-T15-25A-23-S-1-P2-1

Unit size	PWX-90/2
Fan type	F7 (Pod fans)
Unit handing	Right hand
Heat exchanger type	4-pipe, heating & cooling
Valve package	Cooling & heating valves factory supplied & fitted
Condensate tray	Epoxy painted
Discharge outlet type	Ø248mm spigots
Active spigots Inlet	2, 3
Filter	Washable fabric, EU2/G2
Inlet type	Inlet with fixings to accept inlet attenuator/plenum
Condensate pump	Supplied loose for site fitting, pre-wired power cable
Controls	BACnet controls, factory supplied & fitted

Dimensions

Unit shown within catalogue diagrams depict right hand control (...-R). For left hand control, drip tray and coil connections will be on opposite side.

Handing is defined as the side on which coil connections and drip tray are located when looking into the FCU inlet.

For 2-pipe & 4-pipe variants, electrical controls enclosure will be mounted on the same side as coil connections ⁽¹⁾

Where electric heating is specified (...-E2, ...-E4), controls enclosure will be mounted on opposite side to coil connections ⁽²⁾

Note:

Minimum 300 mm clearance should be allowed below each unit to facilitate inspection and maintenance.

Clearance should also be allowed around inlet filter and controls enclosure. .

PWX - * ... / R ... / **A (Circular discharge spigots)

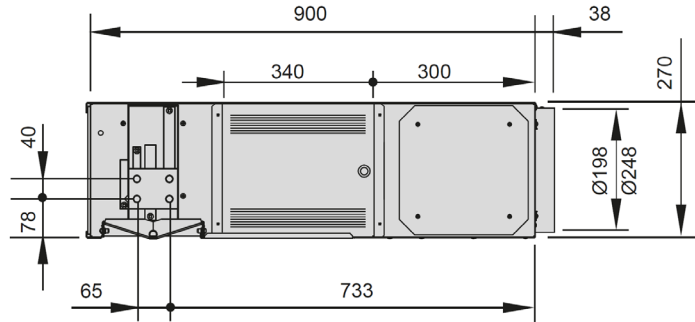

PWX - * ... / R ... / 20R (Rectangular discharge spigot)

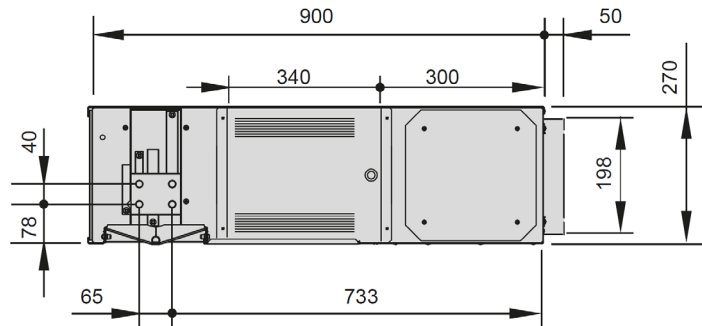

Right hand (...-R) coil connection detail shown. For left hand units (...-L), cooling & heating positions are reversed.

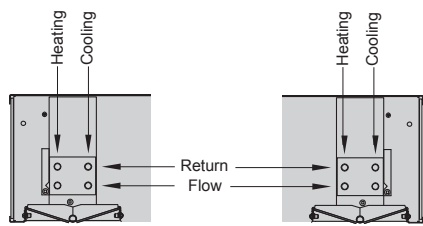

Right hand (...-R) coil connection detail

Left hand (...-L) coil connection detail

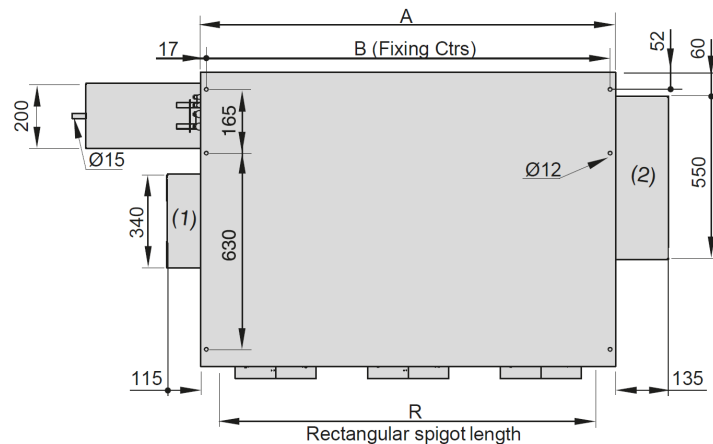

PWX Dimensions			
Unit	A	B	R
PWX-60	668	634	498
PWX-90	968	934	798
PWX-120	1268	1234	1098
PWX-150	1568	1534	1398
PWX-180	1868	1834	1698
PWX-205	2118	2084	1948

Coil connection [mm]		
Unit	Cooling	Heating
PWX-60	Ø15	Ø15
PWX-90	Ø15	Ø15
PWX-120	Ø15	Ø15
PWX-150	Ø22	Ø15
PWX-180	Ø22	Ø15
PWX-205	Ø22	Ø15

PWX spigot handing

Spigot handing is defined using the adjacent diagrams when looking into the discharge.

Unless specified, PWX units will be delivered with all front facing spigots active.

Additional spigots or spigot blanking plates can be supplied on request.

PWX -60...-90

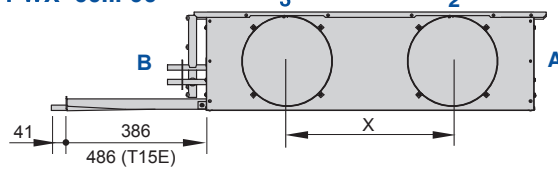

PWX -120

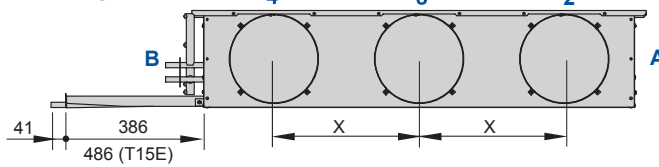

PWX -150...-180

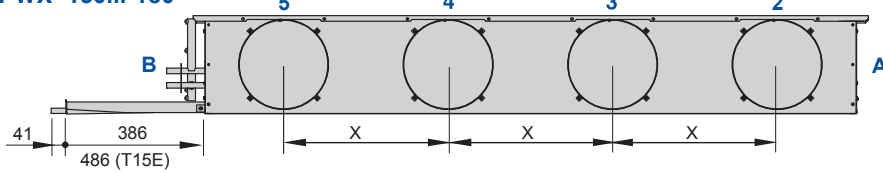

PWX -205

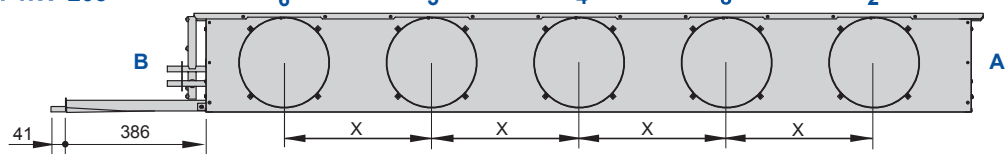

PWX Dimensions		
Unit	X	Spigot Opt.
PWX-60	300	A,2,3,B
PWX-90	455	A,2,3,B
PWX-120	405	A,2,3,4,B
PWX-150	375	A,2,3,4,5,B
PWX-180	455	A,2,3,4,5,B
PWX-205	405	A,2,3,4,5,6,B

PWX Weight	
Unit	kg
PWX-60	25.0
PWX-90	40.0
PWX-120	55.0
PWX-150	70.0
PWX-180	85.0
PWX-205	100.0

Fan electrical data

The tables opposite provide electrical data for the PWX fan range.

Values are based on PWX selections with ESP of 30 Pa.

For project specific values, please contact your local TROX representative.

PWX Type F7				
Unit	Running current	Watts	Starting current	Inrush current
PWX-60/1	0.4A	35	0.4A	5.5A ~ 10ms
PWX-90/1	0.5A	55	0.5A	5.5A ~ 10ms
PWX-90/2	0.5A	60	0.5A	11.0A ~ 10ms
PWX-120/2	0.8A	90	0.8A	11.0A ~ 10ms
PWX-120/3	1.0A	100	1.0A	16.5A ~ 10ms
PWX-150/3	0.9A	100	0.9A	16.5A ~ 10ms
PWX-180/3	1.2A	150	1.2A	16.5A ~ 10ms
PWX-180/4	1.1A	130	1.1A	22.0A ~ 10ms
PWX-205/4	1.3A	150	1.3A	22.0A ~ 10ms

PWX Type F10				
Unit	Running current	Watts	Starting current	Inrush current
PWX-60/1	-	-	-	-
PWX-90/1	-	-	-	-
PWX-90/2	0.6A	80	0.6A	16.0A ~ 4ms
PWX-120/2	0.9A	115	0.9A	16.0A ~ 4ms
PWX-120/3	1.0A	135	1.0A	16.0A ~ 4ms
PWX-150/3	1.2A	160	1.2	16.0A ~ 4ms
PWX-180/3	1.6A	215	1.6A	16.0A ~ 4ms
PWX-180/4	1.3A	170	1.3A	32.0A ~ 4ms
PWX-205/4	1.2A	160	1.2A	32.0A ~ 4ms

Recommended fuse size: 2A HRC T - time delay

EMC testing



Electromagnetic compatibility

The Electromagnetic Compatibility (EMC) Directive 2014/30/EU applies to all electronic or electrical products liable to cause or be disturbed by electromagnetic interference (EMI). Type PWX fancoils have been

independently tested to comply with radiated and conductive emissions and immunity limits defined within the directive. Type PWX also complies with Low Voltage Directive (LVD) 2014/35/EU.

Standards applied

- BS EN 60204-1:2006+A1:2009: Safety of machinery. Electrical equipment of machines. General requirements
- BS EN 61000-6-1:2007: Electromagnetic compatibility (EMC). Generic standards. Immunity for residential, commercial and light-industrial environments
- BS EN 61000-6-2:2005: Electromagnetic compatibility (EMC). Generic standards. Immunity for industrial environments
- BS EN 61000-6-3:2007+A1:2011: Electromagnetic compatibility (EMC). Generic standards. Emission standard for residential, commercial and light-industrial environments

EMC standards passed

- BS EN 61000-6-3:2007+A1:2011: Emission standard for residential, commercial and light industrial environments. Table 1.1: Class B limits for radiated emissions
- BS EN 61000-4-3:2006+A2:2010: Radiated, radio-frequency, electromagnetic field immunity test
- BS EN 61000-6-3:2007+A1:2011: Emission standard for residential, commercial and light industrial environments. Table 2.1: Class B limits for conducted emissions
- BS EN 61000-3-2:2014: Limits for harmonic current emissions (equipment input current ≤ 16 A per phase)
- BS EN 61000-3-3:2013: Limitation of voltage changes, voltage fluctuations and flicker in public low-voltage supply systems, for equipment with rated current ≤ 16 A per phase and not subject to conditional connection
- BS EN 61000-4-11:2004: Voltage dips, short interruptions and voltage variations immunity tests
- BS EN 61000-4-5:2014: Surge immunity test
- BS EN 61000-4-4:2012: Electrical fast transient/burst immunity test
- BS EN 61000-4-6:2014: Immunity to conducted disturbances, induced by radio-frequency fields
- BS EN 61000-4-2:2009: Electrostatic discharge immunity test (ESD)

PWX electric heating

Type PWX fancoils can be supplied as standard with an integral electric heating package. Suitable for applications where heating demand is low and infrequent, electric heating can offer a cost effective solution where existing hot water systems are not available.

Implementation of electric heating systems tend to be more complex than traditional LTHW based heating systems with additional control required for safe operation. Please contact your local TROX representative for guidance on best practice implementation.

Electric heating



Special characteristics

- Electric heaters with Kanthal D (or equivalent) element, magnesium oxide insulation contained within 304 grade stainless steel tube. Stainless steel helical fin surround.
- High temperature cut out set to ~40°C with auto-reset at ~30°C
- Airflow proving via integral pressure switch to prevent heating element activation at low airflow
- Variable element output (0-10V control voltage required) via TROX supplied solid state thyristor

Specification

- Supply 230Vac, 1Ph, 50/60 Hz
- Insulation resistance >1M OHM
- Leakage current < 0.1mA (230Vac)

Features

- 230V AC supply
- BS7671 compliant, IET wiring regulations
- LVD 2014/35/EU compliant
- BS7797:1998 Specification for industrial duct heaters using metal sheathed elements

Max electric heater size

The table opposite provides maximum electric heater element size available within PWX range.

Alternative heater sizes can be reviewed upon request.

PWX Electric Heater Sizes		
PWX unit size	MAX element size	MIN airflow
	(kW)	(l/s)
PWX-60/1	0.8kW	126
PWX-90/1	1.5kW	194
PWX-90/2	1.5kW	194
PWX-120/2	2.0kW	263
PWX-120/3	2.0kW	263
PWX-150/3	3.0kW	331
PWX-180/3	3.0kW	400
PWX-180/4	3.0kW	400
PWX-205/4	4.0kW	457

Commissioning

Unlike LTHW heating, electric heating applications require a minimum air velocity across the element to ensure safe operation.

To prove airflow, Type PWX fancoils are supplied with an integral pressure switch designed to allow activation of electric heating only when sufficient airflow (pressure) is achieved.

To ensure minimum airflow rates are achieved, Type PWX fancoils equipped with electric heating must be commissioned to achieve the minimum airflow rates at the specified external static pressure (30 Pa).

TROX control packages

Type PWX fancoils can be supplied as standard with a wide range of controls from simplistic single zone (room) control to more sophisticated BMS compatible BACnet controllers.

Integrated TROX control strategies, including energy efficient VAV functionality are supplied as standard however project specific functionality can be programmed upon request.

In addition to electrical control, TROX are able to offer a complete package of waterside controls. Various sensor packages can also be included to offer monitoring of all performance aspects.

For more information on TROX control packages, please contact your TROX representative.

BACnet control

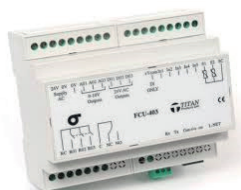

BACnet Enabled

Special characteristics

- Titan FCU-4 is designed to provide complete control of fancoil units. The FCU-4 controller incorporates all the inputs and outputs to ensure that this advanced applications specific controller meets all the demands for energy efficient and flexible temperature control.
- The controller can be used stand-alone, in a Master/slave group or part of a BMS system via the standard inbuilt Native BACnet MS/TP communications. A remote digital room unit (RDU-4) is also available to allow occupants to set individual comfort conditions.

Features

- 24V AC supply
- Native BACnet communications
- Master/slave grouping (shared information)
- 0-10V outputs up to 4 depending on configuration
- Up to 4x 24V AC triac outputs dependent on configuration
- TPC/PWM or on/off control on triac outputs
- 5x 0-10V analogue inputs or use as digital inputs
- 3x VF interlocked relays for fan control
- 1x VF changeover relay
- On/off, ECO, frost settings or high limit
- 2 x 10K3 temperature sensor inputs
- Extensive applications selection
- Remote setpoint display option
- Time clock
- System flush
- Hours run for filter maintenance

Control settings

- The settings listed describe a range of the standard settings, options and operational features that are available from the applications library. All settings can be accessed and modified with the FPT-601 field programming tool or over the BACnet communications interface.
- If a RDU-4 is installed it can also provide access via a coded entry to engineers setting but this does not allow alteration of the controller I/O configuration. Local user settings such as fan speed, temperature setpoint and scheduling can be done through the use of the RDU-4 room display unit.

- The FCU-4 can be used with a remote room display unit the RDU-4 which allows user selection of temperature, heating / cooling modes, fan speed, scheduling and on/off override functionality.
- The RDU-4 also allows (through engineers pass code) access to amend the controller default settings. For controllers not fitted with an RDU-4 then the plug in FPT1000 field programming tool can be used for programming purposes. In addition all the settings can be modified over the BACnet communications interface.

Specification

- Supply 24VAC/DC
- Power consumption.....3Va (no RDU) + output 8VA with RDU display
- Triac outputs.....350mA max
- 0-10V outputs.....5mA max
- Temperature sensors 10K3A1
- Analogue inputs 0-10V
- Digital inputs Voltfree
- Relay outputs 240V 5 amp max
- Communications Native BACnet
- Network.....MS/TP -RS485- Indication
- Indication Tx/Rx comm's
- Enclosure..... Din Mounting (IP20) L94-VO
- Size 106mm wide 92mm high 62mm deep

Settings

- Network..... Native BACnet or standalone
- Unit address Range 1 to 127
- MAC address on (master) MS/TP bus
- Baud rate Range opt. 9,600
- Set comm. baud rate 19,200 38,400 76,800
- Dev object ID Range 0 to 4194302
- Allows setting of the device object ID

TROX VAV control

This specific text describes the general properties of the product

TROX VAV fancoil control strategy (shown below) is based on the fundamental principle of running the fans at the lowest speed for the longest duration possible while maintaining the set point temperatures within the air conditioned space.

The most important factor for VAV control is to define the air volume range that the fans will be operating within i.e. minimum and maximum volumes.

– **Maximum air volume:** Commissioned airflow rate that will deliver the output required at peak design conditions

– **Minimum air volume:** Minimum operational airflow rate for the given FCU size during dead-band condition.

NOTE: Consideration must be given to the operational range of any air terminal device connected to the FCU when selecting minimum air volume.

PWX VAV control diagram

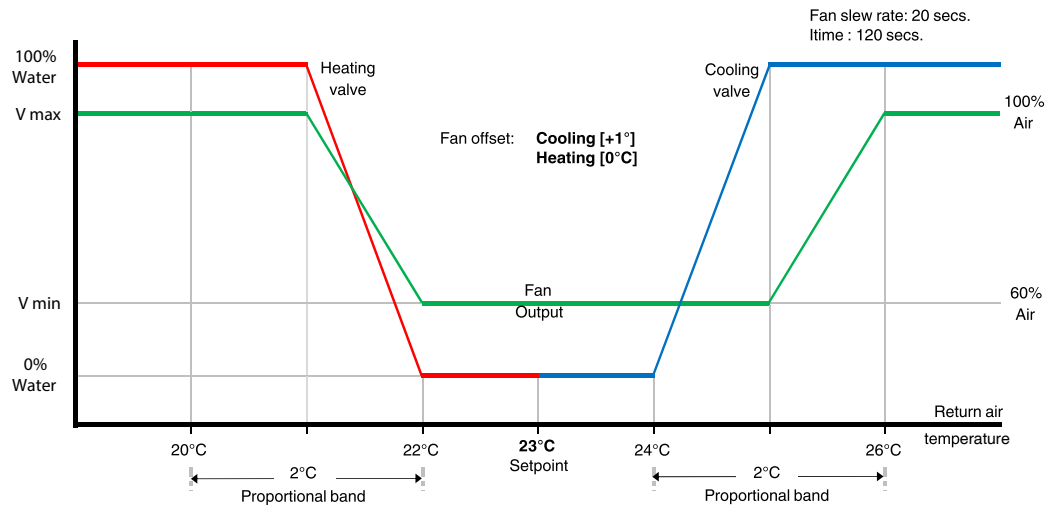

Room control



Special characteristics

- Siemens RDG160T room controller is designed to offer standalone control of TROX Type PWX fancoil units for applications where central BMS systems are not available.
- Wall mounted controller with digital display for use with single unit control zones.
- Maintenance of room temperature via built-in temperature sensor or optional external room temperature/return air temperature sensor

- The room thermostat consists of two parts: Plastic housing which accommodates the electronics, the operating elements and the room temperature sensor Mounting plate with the screw terminals
- Housing engages in the mounting plate and is secured with 2 screws.

Features

- Maintenance of room temperature via built-in temperature sensor or optional external room temperature/return air temperature sensor
- Automatic or manual changeover between heating and cooling mode
- Selection of operating mode via the operating mode button on the thermostat
- 1-speed, 3-speed or DC 0...10 V fan control (automatic or manual)
- Display of current room temperature or setpoint in °C and/or °F
- Button lock (automatic or manual)
- 1 digital input, freely selectable for: Operating mode switchover contact (keycard) Automatic heating/cooling changeover contact Electric heater enable Dewpoint sensor Fault input
- 2 multifunctional inputs, freely selectable for: Operating mode switchover contact (keycard) Automatic heating/cooling changeover sensor External room temperature or return air temperature Dewpoint sensor Electric heater enable Fault input Supply air temperature sensor
- Advanced fan control function, i.e. fan kick, fan start, selectable fan operation (enable, disable or depending on heating or cooling mode)
- Purge function together with 2-port valve in a 2-pipe changeover system
- Reminder to clean filters
- Minimum and maximum supply air temperature limitation
- 7-day time program: 8 programmable timers to switch over between Comfort and Economy mode
- Selectable relay function; For switching OFF external equipment OFF during Protection mode For switching ON external equipment (such as. pump) during H/C demand Output heating/cooling sequence

Specification

- Rated voltage.....SELV AC/DC 24V
- Frequency..... 50/60 Hz
- Power consumptionMax. 2 VA/1 W
- No internal fuse
- Actuator control.....SELV DC 0...10V, (Y10 - G0/Y20 - G0 [G]) Max. +/-1 mA

Multifunctional inputs

- X1-M/X2-M
- Temperature sensor input
 - TypeNTC (3 kΩ at 25 °C)
 - Temperature range0...49 °C
 - Cable length..... Max. 80 m
- Digital input
 - Operating action.....Selectable (NO/NC)
 - Contact sensingDC 0...5 V, Max. 5 mA
 - Parallel connection of..... Max. 20 thermostats several thermostats per switch for one switch
- D1-GND
 - Operating action.....Selectable (NO/NC)
 - Contact sensingDC 6...15 V, 3...6 mA
 - Parallel connection of..... Max. 20 thermostats several thermostats per switch for one switch

Function of inputs..... Selectable

- External room temp..... X1: P38 sensor, heating/cooling
- Changeover sensor, X2: P40 operating mode switchover
- Contact, dewpoint D1: P42 monitor contact, enable electric heater contact, fault contact, monitoring input, supply air temperature

Waterside control valves

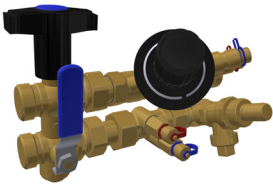

TROX Type PWX fancoil unit can be supplied with a complete package of waterside control valves, designed to integrate with both BACnet and room control packages.

Valve sizing is performed on design flow rate. Several variations of the ECOPICV and 6 venturi size enables optimum selection.

The pressure independent control valve controls the flow rate, irrespective of fluctuations in available differential pressure or the head loss of the coil.

The only other factor that needs to be considered is that there is enough differential pressure to meet the start-up pressure of the valve.

Features

Marflow Xterminator 'X4' series valve sets include;

- EVOPICV axial pressure independent control valve to maintain design flow rate and provide modulating temperature control
- Venturi flow measurement device for flow verification purposes.
- Isolation on both the flow and return legs
- Flushing by-pass and blow down valve to allow valve set and connected terminal unit to be flushed out of circuit and subsequently back flushed.

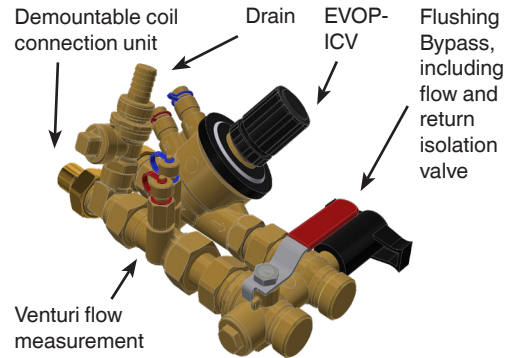

Base Code	PICV		Selection flow rates		Extended range flow rates		Venturi size	Kvs	PICV MIN ΔP	Assy' MIN ΔP
			Min	Max	Min	Max				
	Size	Type	(kg/s)	(kg/s)	(kg/s)	(kg/s)	mm	(kPa)	(kPa)	
OX4BIRxxA0	1/2"	VL	0.008	0.032	0.008	0.040	3.00	0.37	20	(20) 25
OX4BIRxxB0	1/2"	L	0.033	0.063	0.028	0.077	4.25	0.72	25	(20) 28
OX4BIRxxC0	1/2"	L	0.064	0.121	0.054	0.148	6.00	1.38	25	(30) 40
OX4BIRxxD0	1/2"	H	0.122	0.192	0.090	0.245	7.50	2.28	30	(40) 40
OX4BIRxxE0	3/4"	L	0.193	0.249	0.132	0.363	9.0	3.37	30	(40) 40
OX4BIRxxF0	3/4"	H	0.250	0.377	0.185	0.506	10.5	4.70	30	(40) %0

- Selection flow rate indicates the minimum and maximum range of design flow rates that under normal conditions (at design time) the Xterminator is selected to serve
- Extended range flow rates indicate the maximum range of design flow rates that the Xterminator can be used to control and measure, even if it is not usually selected to serve these flow rates. This can be used to determine if a valve set needs to be modified should the design flow rate change post installation. Flows in this extended range may generate signal pressure losses across the venturi of between 0.5kPa and 15kPa

- PICV Min ΔP is the minimum differential pressure required to provide pressure independent flow control for each PICV selection, where the PICV is 100% open. This can be measured across the test points fitted to the PICV. This value reduces as the valve is regulated.
- Assembly Min ΔP is the pressure loss through the Xterminator with the PICV valve set to provide the maximum extended range flow rate and allowing for the minimum differential pressure requirement of the PICV to be met. This value can be used during pump selection. The value in brackets is the total pressure loss at the selection flow rate.

Authority

- The authority (n) of a valve can be calculated from the pressure drop across that valve compared with the local system. In this case written as

$$n = \frac{Pa}{Pa + Pb}$$

- In the case of a pressure independent control valve the differential pressure across the control valve is controlled to the same value regardless of whether the valve is fully open, closed or at part load. This means that a pressure independent control valve has an authority of 1.

Valve actuators



0-10v proportional control actuators suitable for EVOPICV valves. The actuator is a compact unit that is field configurable such is suitable for a wide range of applications.

Factory set to 0-10v modulating (24v), 3.2mm stroke. Field configurable, input signal, action direction, actuator characteristic and stroke length. 120Nm closing force and 8sec/mm speed.

The actuator can be controlled by a number of different signals, including 0-10v, 2-10v, 0-5v, 5-10v and 4-20mA. The actuator is factory set to 0-10v.

Supplied with 1.5m Cable, and adaptor ring. As supplied stroke suits 1/2" and 3/4" EVOPICV. Actuator can be configured to suit 1" and 1/14" EVOPICV by moving internal jumper.

Features

- Stroke direction factory set to reverse acting, this may be changed in the field if required. In order to suit the EVOPICV, the actuator should be set to reverse acting as the EVOPICV is normally open. This will allow the actuator to work with controllers that are set to direct acting without needing any change to the controls.
- In order to adapt the stroke length to different valves, there is a jumper that will change the effective stroke length. This jumper is factory set but can be changed on site if required. Please note that while the actuator will self calibrate to find the closing position, it works on a fixed stroke basis.
- When the power is applied, the actuator self-calibrates performing a complete cycle. The actuator moves the stem down for a complete mechanical valve stroke until no changes are detected. Once the auto-zero is detected the actuator moves the stem accordingly with the input signal.
- When the input signal is at 100% the actuator turns on every 2 hours and drives in the signal direction for approximately 60 seconds to confirm the end of stroke position.
- The connection cable is fitted with a plug so that the actuator can be swapped without unwiring the cable from the controller.
- When the signal is applied in the same direction, the actuator turns on every 2 hours and drives in the signal direction for approximately 90 seconds to confirm the end of stroke position.

Control input

- The actuator is controlled on a drive open, drive closed basis. When the signal is applied to the black and red wires, the actuator stem extends. When the signal is removed the actuator remains in position. If the signal remains applied to the red wire, the actuator will time out and shut off the motor after approximately 90 seconds. When the signal is applied to the black and orange wires, the actuator stem retracts. When the signal is removed the actuator remains in position. If the signal remains applied to the orange wire, the actuator will time out and shut off the motor after approximately 90 seconds.

Control strategy

- The actuator has a maximum stroke of 6mm making it suitable for a number of different valves, however there are a few things that need to be taken account of in the BMS controller strategy.

To ensure the best control characterisation it is vital to match drive time to the valve stroke so that there is no air gap between the actuator spindle and the valve spindle.

The drive time should be calculated by multiplying the stroke length of the valve in mm by the time to drive 1mm. All 3 point actuators need periodic re-synchronisation to account for positional drift, the re-synchronisation time should be set to 90 seconds in the closing direction of the valve.

Fitting kits

TROX can supply various fitting kits to adapt the Euroconus ends of the Xterminator to different pipe systems. A fitting kit consists of a pair of fittings (flow and return).

TROX NX series valve package is supplied complete with 15mm or 22mm capillary solder fittings for the union between heat exchanger and valve.

Copper capillary solder connections for union with FCU

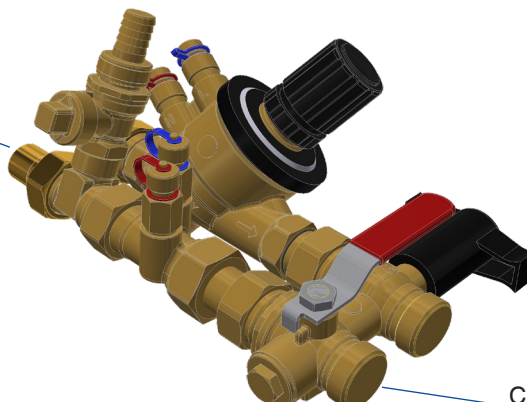

Customer connection end.
Refer to connection options below

Customer connection

Copper capillary solder (15mm or 22mm)

- Capillary solder fittings are available to suit 15mm and 22mm pipe. Ensure fittings are properly cleaned before soldering and that any O-rings have been temporarily removed.
- Pressure rating:PN25
- Temperature rating:0 - 100°C
- Tightening torque:30Nm

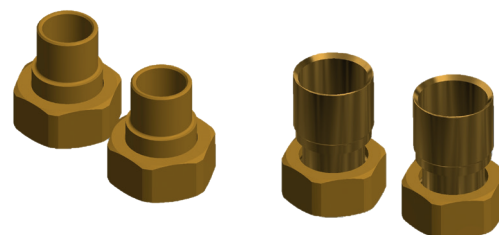

Threaded male BSP (1/2" male taper union)

- Copper, male 3/4" Euroconus - 1/2" male BSP connectors. Taper union
- Pressure rating:PN25
- Temperature rating:0 - 100°C
- Tightening torque:30Nm

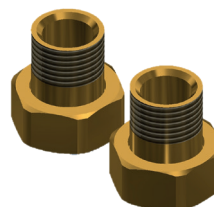

Copper 3/4" flat face adaptor

- Short adaptors from 3/4" Euroconus to 3/4" flat face male are used to facilitate the use of proprietary fittings from other manufacturers. Using these adaptors enables almost all pipe systems to be accommodated by selecting fittings with a 3/4" swivel nut.
- Pressure rating:PN25
- Temperature rating:0 - 100°C
- Tightening torque:30Nm



3rd party fittings

- Although the Euroconus connection is based on a standard G3/4" thread, its short length and the relief on the back side will make it difficult to effect a seal, as such use of non-union type pipe fittings is not recommended. If you should choose to ignore this advice please consider using a liquid thread sealant (of adequate strength) rather than traditional pipe jointing methods.

Free issue controls

TROX offer a comprehensive 'free issue' controls fitting service to complement Type PWX. Bespoke wiring diagrams can be prepared based on project specific control components on request.

In addition to the 'free issue' controls, TROX can supply a range of ancillary components. Please contact TROX for confirmation of additional costs.

Free issue components

Free issue components (by customer)

- BMS outstation or controller maximum overall footprint of controller should be less than 205mm x 130mm. Controller supplied unconfigured by TROX. Additional wiring terminals not included.
- 2 or 4 port control valves must be supplied as complete, assembled & tested valve sets, suitable for installation on 40mm pipe centers. Must be supplied with suitable compression / solder fittings to suit standard PWX coil tails. Maximum length of assembled valve set < 245mm
TROX fitting cost excludes;
 - Transformation fittings or pipework adaptors
 - Additional terminals for wiring (actuators)
 - Extended drip tray
- Supply / return air temperature sensors wired to free issue controller by TROX and coiled up for installation on site.

Optional components (supplied by TROX)

- 0-10v potentiometer for CAV or manual fan speed control
- Fan enable relay (24V / 240V)
- 24V transformer
- Fan status signal
- Traffolyte type labels
- Flying lead (3m LSHF), unterminated ends
- Condensate pump. Supplied loose for site wiring and commissioning by others
- Condensate pump. Pump power connection cable wired to controls enclosure by TROX and coiled up for site installation and commissioning by others
- Factory fit F.I supply air temperature sensor in discharge plenum
- Factory fit F.I return air temperature sensor behind filter

Standard controls

The table provides confirmation of standard controls included within each control type option.

Standard controls				
Controls Options	'0'	'1'	'2'	'F'
BACnet FCU-40X controller	X	✓	X	X
RDG160T room controller	X	X	✓	X
Factory fit F.I FCU controller	X	X	X	✓
NX-EVO 2 port valve set	Opt.	✓	✓	Opt.
Factory fit F.I valve set	X	X	X	✓
230Vac - 24Vac 25VA transformer	Opt.	✓	✓	✓
0-10v potentiometer (CAV or manual speed control)	Opt.	X	X	Opt.
Fan enable relay	Opt.	✓	X	Opt.
Condensate pump (supplied loose) for site install,wiring & commissioning	Opt.	Opt.	Opt.	Opt.
Condensate pump, (pre-wired power cable) for site install & commissioning	Opt.	Opt.	Opt.	Opt.
3m long LSHF mains flying lead (unterminated end)	Opt.	Opt.	Opt.	Opt.
Fan status	Opt.	✓	X	Opt.
3A switched fuse box	Opt.	Opt.	Opt.	Opt.
Supply air temperature sensor - 2m long flying lead	X	✓	✓	X
Return air temperature sensor - 2m long flying lead	X	✓	X	X
Traffolyte type label	Opt.	Opt.	Opt.	Opt.
Factory fit F.I modular T connector	X	Opt.	X	Opt.
Factory fit supply air temperature sensor in outlet plenum	X	Opt.	✓	Opt.
Factory fit return air temperature sensor behind inlet filter	X	Opt.	X	Opt.

Key;

Included as standard ✓

Optional Opt.

Not available with selected control type X

Standard text

This specification text describes the general properties of the product

Waterside fancoil Type PWX designed to provide cooling and heating for comfort and industrial applications. Acoustically optimised EC/DC fans with low specific fan powers and adjustable supply air volume control (0-10v signal). Acoustically lined inlet and discharge plenum provide low sound power levels and improved thermal isolation. 2-pipe or 4-pipe heat exchangers enable high comfort levels. For horizontal installation in ceiling voids, floor voids or exposed applications.

Special characteristics

- Removable access hatch with integrated hinge to facilitate inspection and maintenance
- Independent fan mounting enables individual removal or replacement
- Fire resistant 'Class O' acoustic insulation provides low operating noise levels
- Low thermal conductivity of 0.036 W/m.K provides improved thermal insulation
- Unique 2-way sloping condensate tray design ensures effective removal of condensate along the full length of the tray

Materials and surfaces

- Casing manufactured from 1.2mm galvanised steel
- Condensate drip tray manufactured from 1.2mm galvanised steel, powder-coat finish, RAL 9005 (black), 3mm thick 'Class O', closed cell insulation
- Fire resistant 'Class O' acoustic insulation tested to BS476 Parts 6 & 7

Technical data

Nominal sizes;

- PWX-60: 600 x 900 x 270 mm (W x L x H)
- PWX-90: 900 x 900 x 270 mm (W x L x H)
- PWX-120: 1200 x 900 x 270 mm (W x L x H)
- PWX-150: 1500 x 900 x 270 mm (W x L x H)
- PWX-180: 1800 x 900 x 270 mm (W x L x H)
- PWX-205: 2050 x 900 x 270 mm (W x L x H)
- Minimum volume flow rate (supply air): 50 – 343 l/s or 180 – 1234 m³/h
- Maximum volume flow rate (supply air), at NR 40 (standard room corrections) without attachments: 159 – 636 l/s or 572 - 2289 m³/hr

Sizing data

- Sensible cooling..... [kW]
- Total heating..... [kW]
- CHW flow / return..... [°C]
- LTHW flow / return..... [°C]
- Entering air temperature..... [°C]
- External static pressure..... [Pa]
- Room noise level..... [NR]

Accessories

Inlet / Discharge Attenuator



Inlet and discharge attenuator for noise critical applications

Discharge attenuator Type DA, DAR and inlet attenuator Type IA for the reduction of air regenerated noise. For use with Type PWX waterside fancoil units

- Casing manufactured from 1.2mm galvanised steel
- Mineral wool lining with non-woven glass fibre as protection against erosion due to airflow velocities up to 20 m/s
- Absorption material is non-combustible mineral wool with RAL quality mark, biosoluble and hence hygienically safe according to the German TRGS 905 (Technical Rules for Hazardous Substances) and EU directive 97/69/EC

Application

Application

- Discharge attenuator Type DA and inlet attenuator Type IA for reduction of air-regenerated noise of waterside fancoil unit Type PWX
- Simple and quick installation on site

Nominal sizes

- DA: 540 x 270 mm (L x H)
- DAR: 840 x 270 mm (L x H)
Width (W): 600, 900, 1200, 1500, 1800, 2050 to suit PWX unit size
- IA: 500 x 270 mm (L x H)
Width (W): 600, 900, 1200, 1500, 1800, 2050 to suit PWX unit size

Description

Variants

- DA: Discharge attenuator to suit PWX (only for rectangular spigot option PWX / ...-20R) with rectangular outlet spigots
- DAR: Discharge attenuator to suit PWX (only for rectangular spigot option PWX / ...-20R) with circular outlet spigots
- IA: Inlet attenuator to suit PWX

Parts and characteristics

- Casing
- Absorption material
- Installation bracket for quick-coupling to PWX fancoil unit

Maintenance

- Maintenance-free as construction and materials are not subject to wear

Materials and surfaces

- Casing manufactured from 1.2mm galvanised steel
- Lining is mineral wool

Mineral Wool

- To EN13501, fire rating class A1, non-combustible
- RAL quality mark RAL-GZ 388
- Biosoluble and hence hygienically safe according to the German TRGS 905 (Technical Rules for Hazardous Substances) and EU directive 97/69/EC
- Faced with glass fibre as protection against erosion through airflow velocities up to 20m/s
- Inert to fungal and bacterial growth

Insertion loss

Nominal size	Centre frequency f_m [Hz]							
	63	125	250	500	1000	2000	4000	8000
	D_e							
	Hz							
Inlet attenuator	-1	-4	-5	-11	-12	-14	-14	-12
Discharge attenuator	-3	-3	-7	-14	-21	-20	-20	-15

Discharge attenuator

The tables show the available nominal sizes

PWX-ATTACHMENT / ** / DA

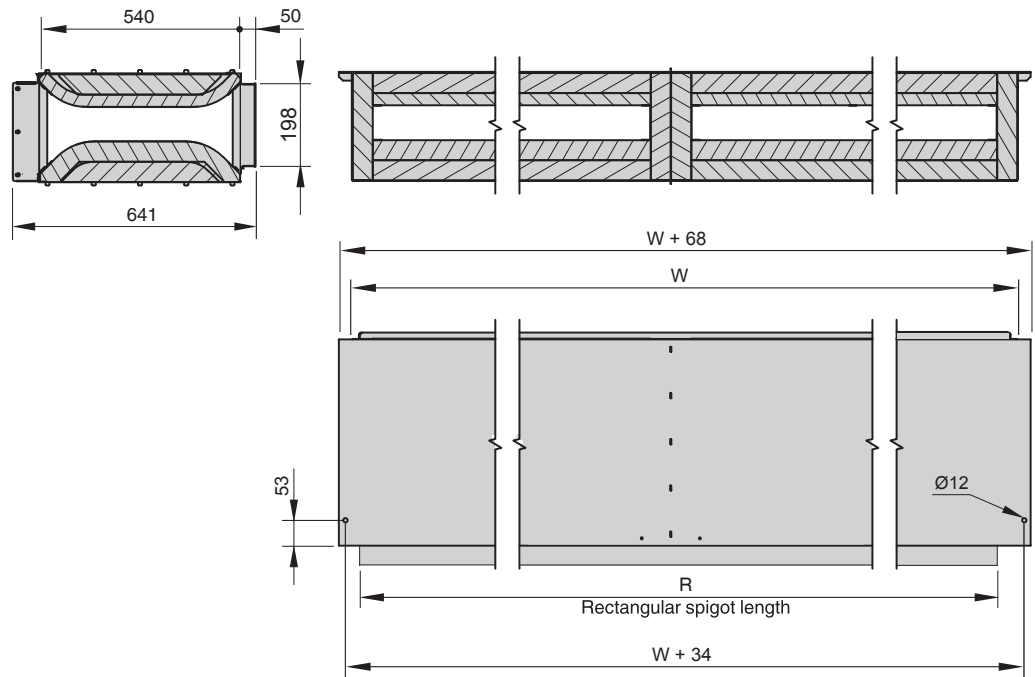

Nominal size	W	R	M
	mm	mm	kg
60 / DA	600	498	14.0
90 / DA	900	798	19.0
120 / DA	1200	1098	24.0
150 / DA	1500	1398	31.0
180 / DA	1800	1698	37.5
205 / DA	2050	1948	44.0

Assembly



Discharge attenuator The tables show the available nominal sizes

PWX-ATTACHMENT / ** / DAR

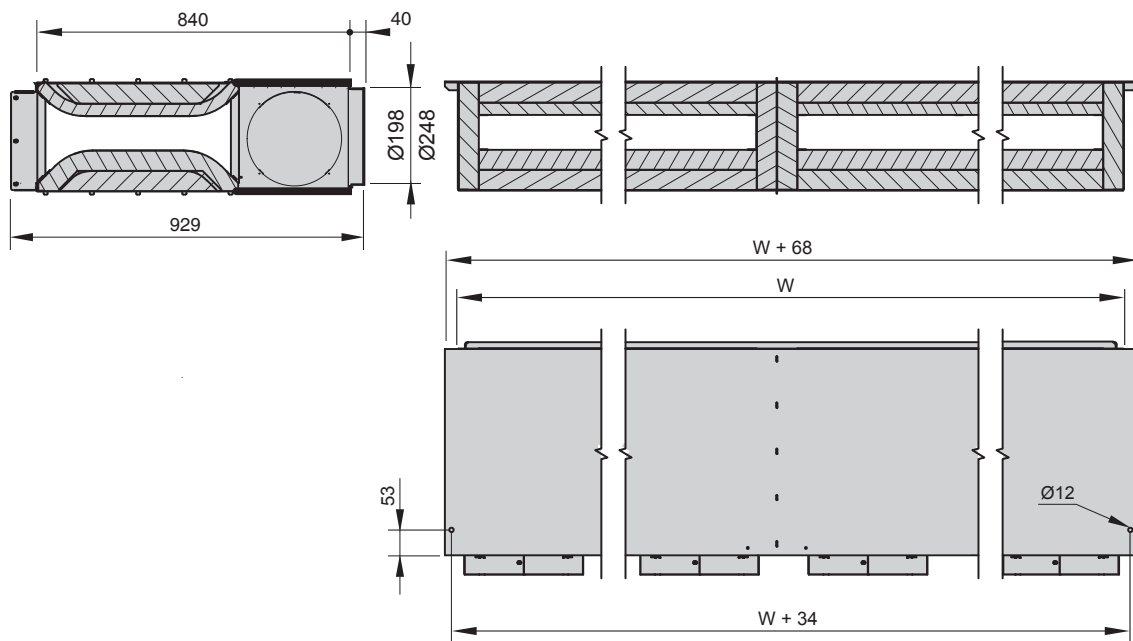

Nominal size	W	M
	mm	kg
60-DAR	600	25.5
90-DAR	900	34.5
120-DAR	1200	45.0
150-DAR	1500	57.0
180-DAR	1800	69.0
205-DAR	2050	81.0

Assembly

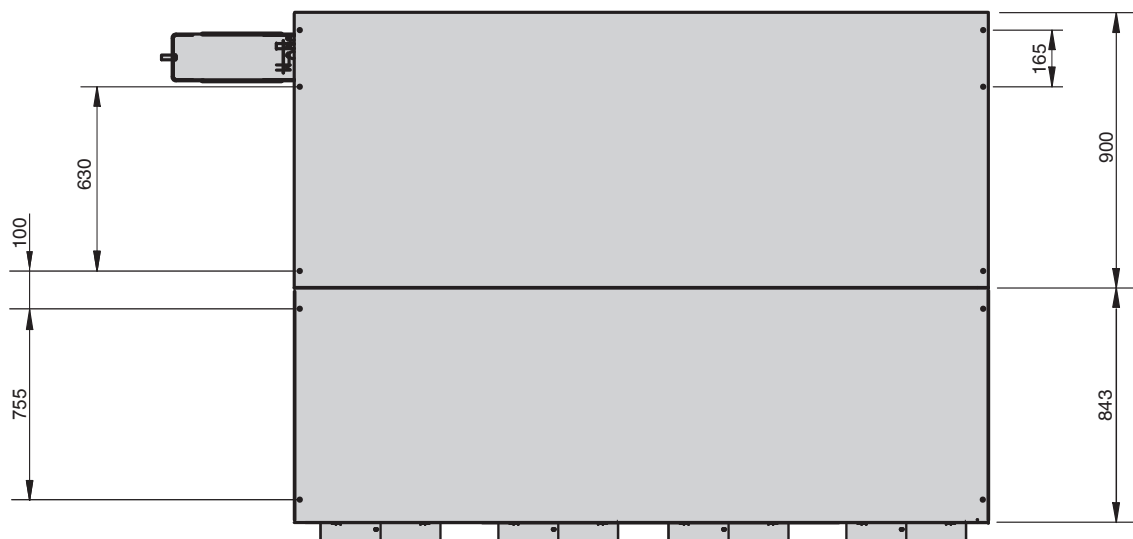

DAR spigot handing

Spigot handing is defined using the adjacent diagrams when looking into the discharge.

Unless specified, Type ...-DAR units will be delivered with all front facing spigots active.

Additional spigots or spigot blanking plates can be supplied on request.

DAR-60...-90

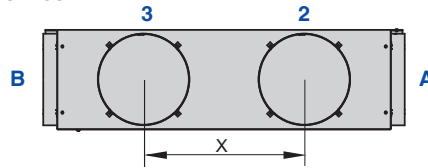

DAR-120

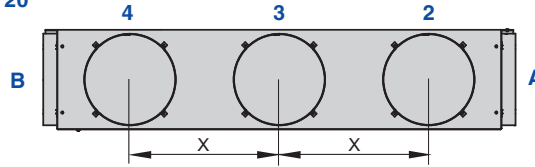

DAR-150...-180

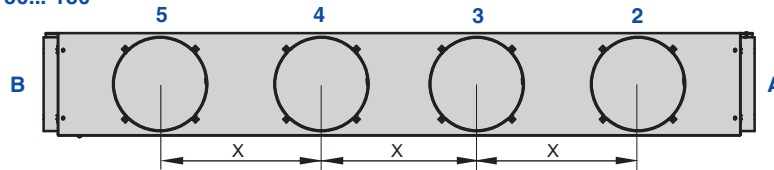

DAR-205

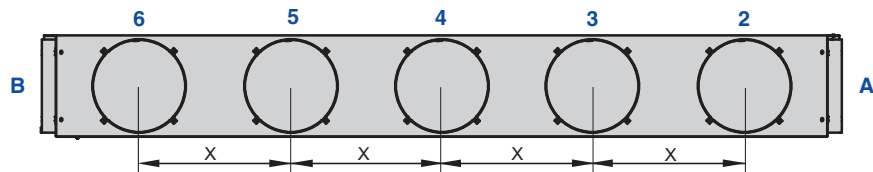

DAR Dimensions		
Unit	X	Spigot Opt.
DAR-60	300	A,2,3,B
DAR-90	455	A,2,3,B
DAR-120	405	A,2,3,4,B
DAR-150	375	A,2,3,4,5,B
DAR-180	455	A,2,3,4,5,B
DAR-205	405	A,2,3,4,5,6,B

Inlet attenuator

The tables show the available nominal sizes

PWX-ATTACHMENT / ** / IA

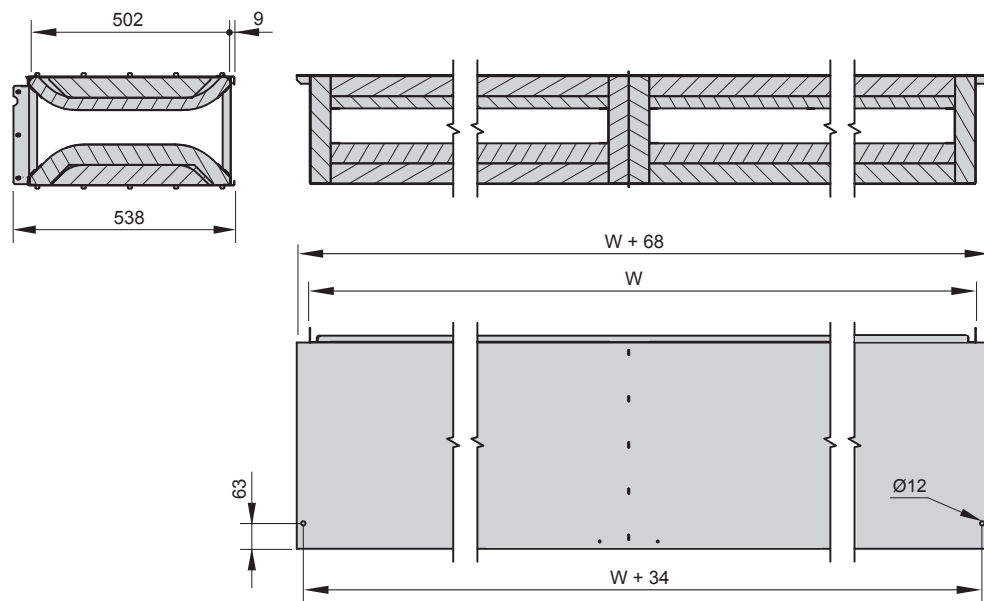

Nominal size	W	M
	mm	kg
A-60	600	11.5
A-90	900	15.5
A-120	1200	21.0
A-150	1500	26.0
A-180	1800	31.5
A-205	2050	37.0

Assembly

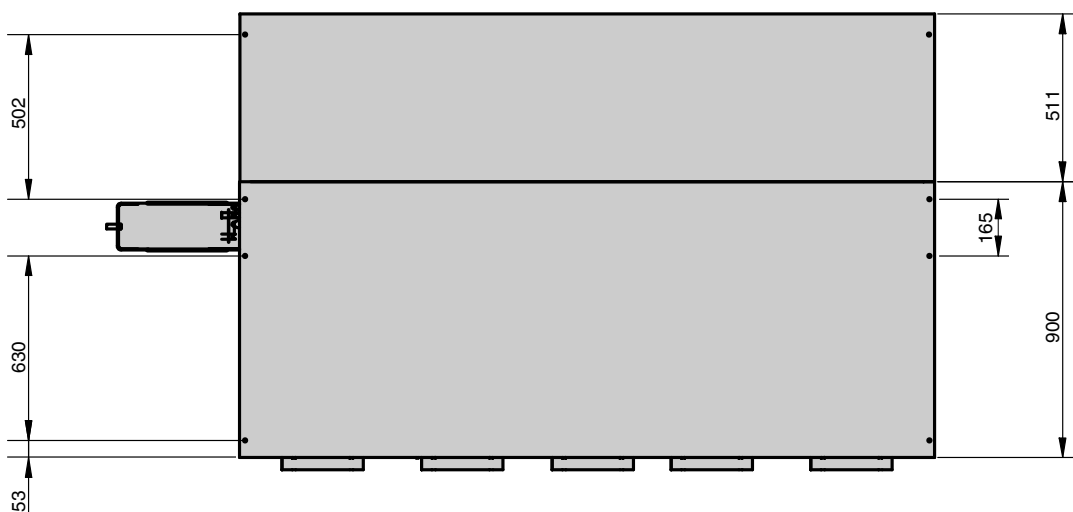

Order Code

PWX-ATTACHMENT

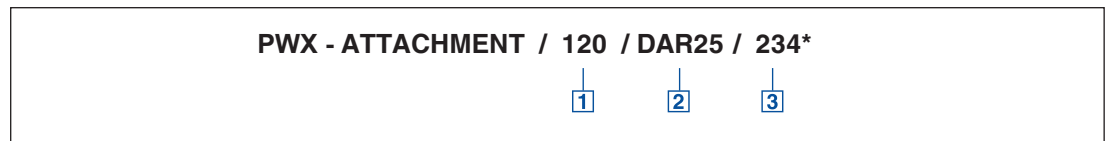

1 Unit size

60, 90, 120, 150, 180, 205

2 Type

- DA** Discharge Attenuator
(rectangular spigot)
- DAR20** Discharge Attenuator
(Ø198mm circular spigots)
- DAR25** Discharge Attenuator
(Ø248mm circular spigots)
- IA** Inlet Attenuator

3 Active spigots*

60	A,2,3,B
90	A,2,3,B
120	A,2,3,4,B
150	A,2,3,4,5,B
180	A,2,3,4,5,B
205	A,2,3,4,5,6,B

*(Type DAR** only)

Order example: PWX-ATTACHMENT / 90 / IA

PWX unit size	90 (900mm x 500mm x 270mm)
Attachment type	Inlet attenuator to suit PWX fancoil
Active Spigots*	Active Spigots*: 2,3,4

Specification text

Rectangular discharge attenuators Type DA, DAR and inlet attenuators Type IA for air conditioning systems, rigid construction from 1.2mm galvanised sheet steel, available in 6 nominal sizes. Casing with mineral wool acoustic insulation. Installation bracket for quick coupling to PWX fancoil units.

Special features

- Absorption material is non-combustible

Materials and surfaces

- Casing manufactured from 1.2mm galvanised sheet steel
- Lining is mineral wool

Mineral Wool

- To EN13501, fire rating class A1, non-combustible
- RAL quality mark RAL-GZ 388
- Biosoluble and hence hygienically safe according to the German TRGS 905 (Technical Rules for Hazardous Substances) and EU directive 97/69/EC
- Faced with glass fibre as protection against erosion through airflow velocities up to 20m/s
- Inert to fungal and bacterial growth

Technical data

- Nominal sizes, 60, 90, 120, 150, 180, 205

Installation

Discharge attenuators Type DA and inlet attenuators Type IA are designed for site fixing to PWX range of waterside fancoils.

Installation brackets on each side of the attenuator align with pre-punched holes, fitted with captive rivnuts pre-installed within PWX FCU's.

Attenuator should be fixed to PWX fan coil using 6 No. M6x16 HEX SET screws (provided) and independently suspended from the building structure.

2x Ø12mm holes are provided within the casing suitable for drop rod or wire supports (by others).

Discharge attenuator

Discharge attenuator Type DA, DAR only for use with rectangular spigot option (...-20R).

PWX fancoil and DA, DAR attenuator should be installed and suspended independently and joined using M6x16 screws (provided).

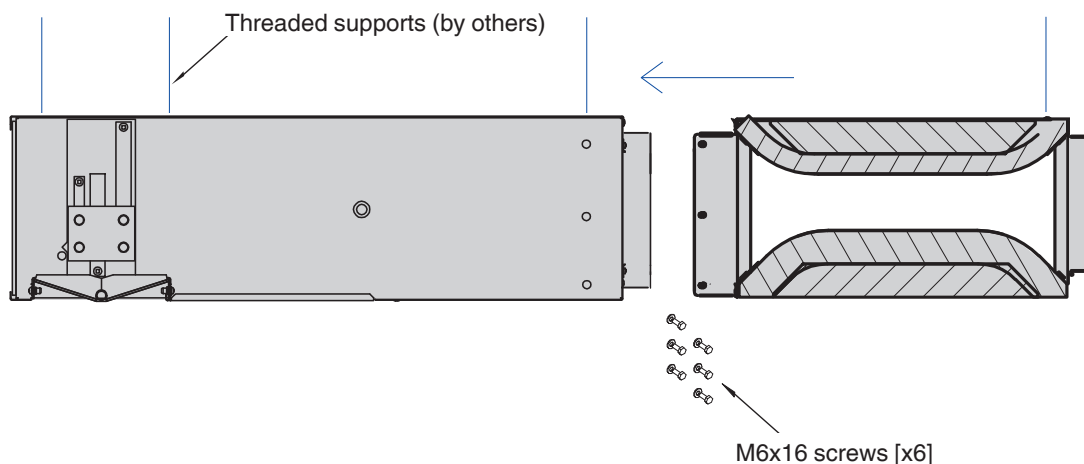

Inlet attenuator

Inlet attenuator Type IA for use with PWX fancoils.

PWX fancoil and IA attenuator should be installed and suspended independently and joined using M6xM16 screws (provided).

Inlet filter must be removed from PWX fancoil and installed within inlet attenuator before joining.

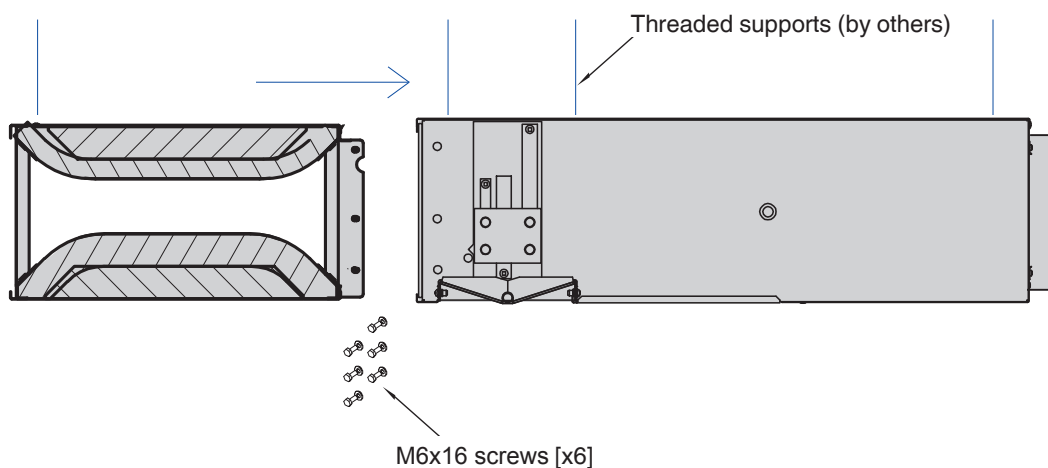

Accessories

Inlet Plenum

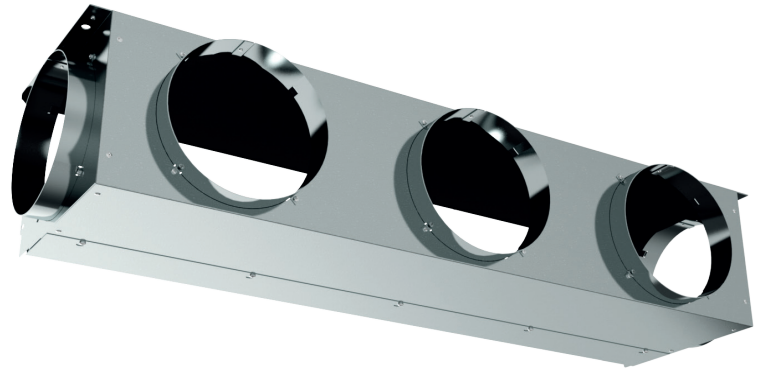

Inlet plenum for ducted return air applications

Inlet plenum Type IP for ducted return air applications where supply and return air must be isolated from the ceiling void. For use with Type PWX waterside fancoil units

- Casing manufactured from 1.2mm galvanised steel
- Fire rated 'Class O' acoustic lining provides low sound power levels and improved thermal insulation
- Adjustable spigot positions allow site modification during installation or during re-fit. Ø198mm or Ø248mm spigots available
- Installation bracket for quick-coupling to PWX fancoil on site

Application

Application

- Inlet plenum Type PWX-Inlet-P for closed, return-air applications for use with Type PWX fancoils.
- Simple and quick installation on site

Nominal sizes

- P-60: 600 x 342 x 270 mm (W x L x H)
- P-90: 900 x 342 x 270 mm (W x L x H)
- P-120: 1200 x 342 x 270 mm (W x L x H)
- P-150: 1500 x 342 x 270 mm (W x L x H)
- P-180: 1800 x 342 x 270 mm (W x L x H)
- P-205: 2050 x 342 x 270 mm (W x L x H)

Description

Variants

- 60 / IP: Inlet plenum to suit PWX-60
- 90 / IP: Inlet plenum to suit PWX-90
- 120 / IP: Inlet plenum to suit PWX-120
- 150 / IP: Inlet plenum to suit PWX-150
- 180 / IP: Inlet plenum to suit PWX-180
- 205 / IP: Inlet plenum to suit PWX-205

Parts and characteristics

- Casing
- Absorption material
- Installation bracket for quick-coupling to PWX fancoil unit

Materials and surfaces

- Casing manufactured from 1.2mm galvanised steel
- Fire rated Class 'O' acoustic foam lining

Maintenance

- Maintenance-free as construction and materials are not subject to wear

Inlet plenum

The tables show the available nominal sizes

PWX-ATTACHMENT / ** / IP

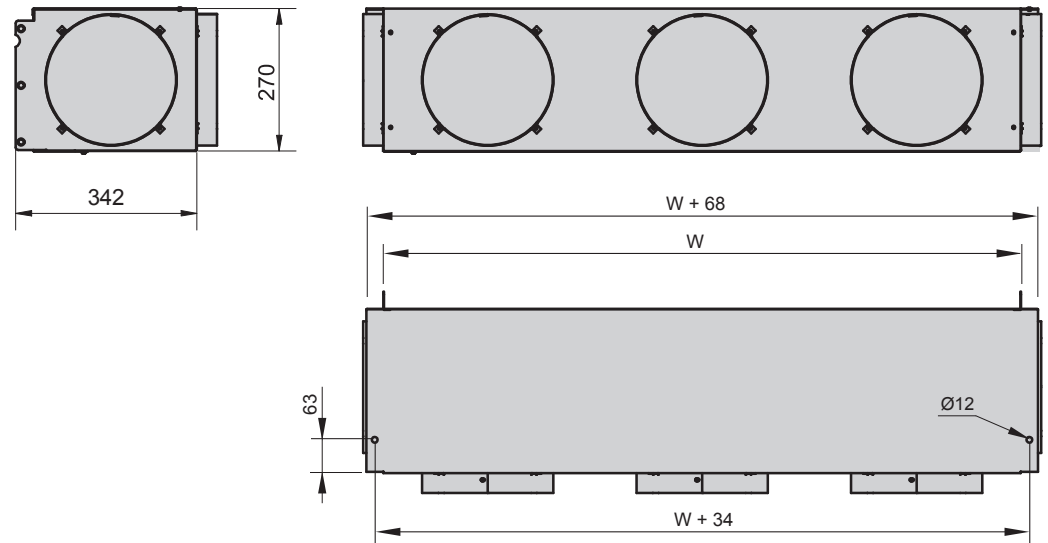

Nominal size	W	M
	mm	kg
60 / IP	600	11.5
90 / IP	900	15.5
120 / IP	1200	21.0
150 / IP	1500	26.0
180 / IP	1800	31.5
205 / IP	2050	27.0

Spigot handing is defined using the adjacent diagrams when looking into the inlet.

Unless specified, Type IP units will be delivered with all front facing spigots active.

Additional spigots or spigot blanking plates can be supplied on request.

PWX -60...-90

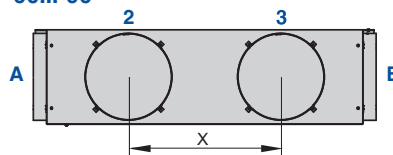

PWX -120

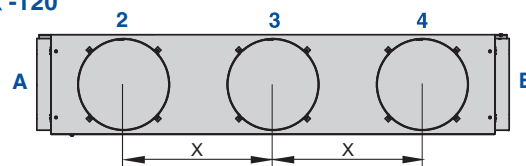

PWX -150...-180

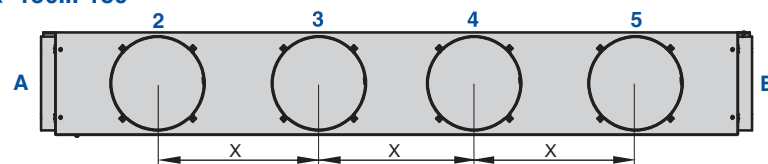

PWX -205

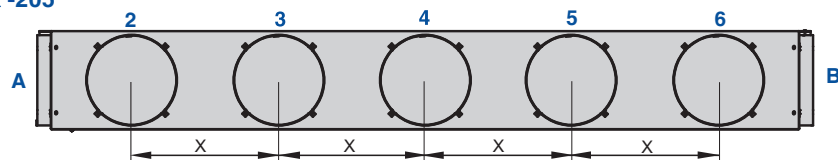

PWX IP spigot dimensions		
Unit	X	Spigot Opt.
PWX-60	300	A,2,3,B
PWX-90	455	A,2,3,B
PWX-120	405	A,2,3,4,B
PWX-150	375	A,2,3,4,5,B
PWX-180	455	A,2,3,4,5,B
PWX-205	405	A,2,3,4,5,6,B

Order code

PWX-ATTACHMENT



1 Unit size

60, 90, 120, 150, 180, 205

2 Unit type

I20 Inlet Plenum Ø 198

I25 Inlet Plenum Ø 248

3 Active spigots

60	A,2,3,B
90	A,2,3,B
120	A,2,3,4,B
150	A,2,3,4,5,B
180	A,2,3,4,5,B
205	A,2,3,4,5,6,B

Order example: PWX-ATTACHMENT / 120 / I25 / 234

Unit type

Inlet plenum Ø248 to suit PWX fancoil

Unit size

120 (1200mm x 500mm x 270mm)

Active spigots

Active spigots: 2, 3, 4

Specification text

Rectangular inlet plenums for air conditioning systems, rigid construction, available in 6 nominal sizes. Casing with Class 'O' acoustic insulation. Installation bracket for quick-coupling to PWX fancoil units.

Special features

- Absorption material is non-combustible

Technical data

- Nominal sizes: 60, 90, 120, 150, 180, 205
- Nominal spigot sizes: Ø198mm or Ø248mm

Materials and surfaces

- Casing manufactured from 1.2mm galvanised steel
- Fire rated Class 'O' acoustic foam lining

Maintenance

- Maintenance-free as construction and materials are not subject to wear

Installation

Inlet plenum Type IP is designed for site fixing to PWX range of waterside fancoils.

Installation brackets on each side of the inlet plenum align with pre-punched holes, fitted with captive rivnuts pre-installed within PWX FCU's.

Type IP should be fixed to PWX fan coil using 6 No. M6x16 HEX SET screws (provided) and independently suspended from the building structure.

2x Ø12mm holes are provided within the casing suitable for drop rod or wire supports (by others).

Inlet plenum

Inlet plenum Type IP for use with PWX fancoils.

PWX fancoil and inlet plenum should be installed and suspended independently and joined using M6x16 screws (provided).

Inlet filter must remain within PWX fancoil and accessed for cleaning and/or replacement from below

