

PRODUCT AND INSTALLATION MANUAL

wavin **OSMA**

Rainwater

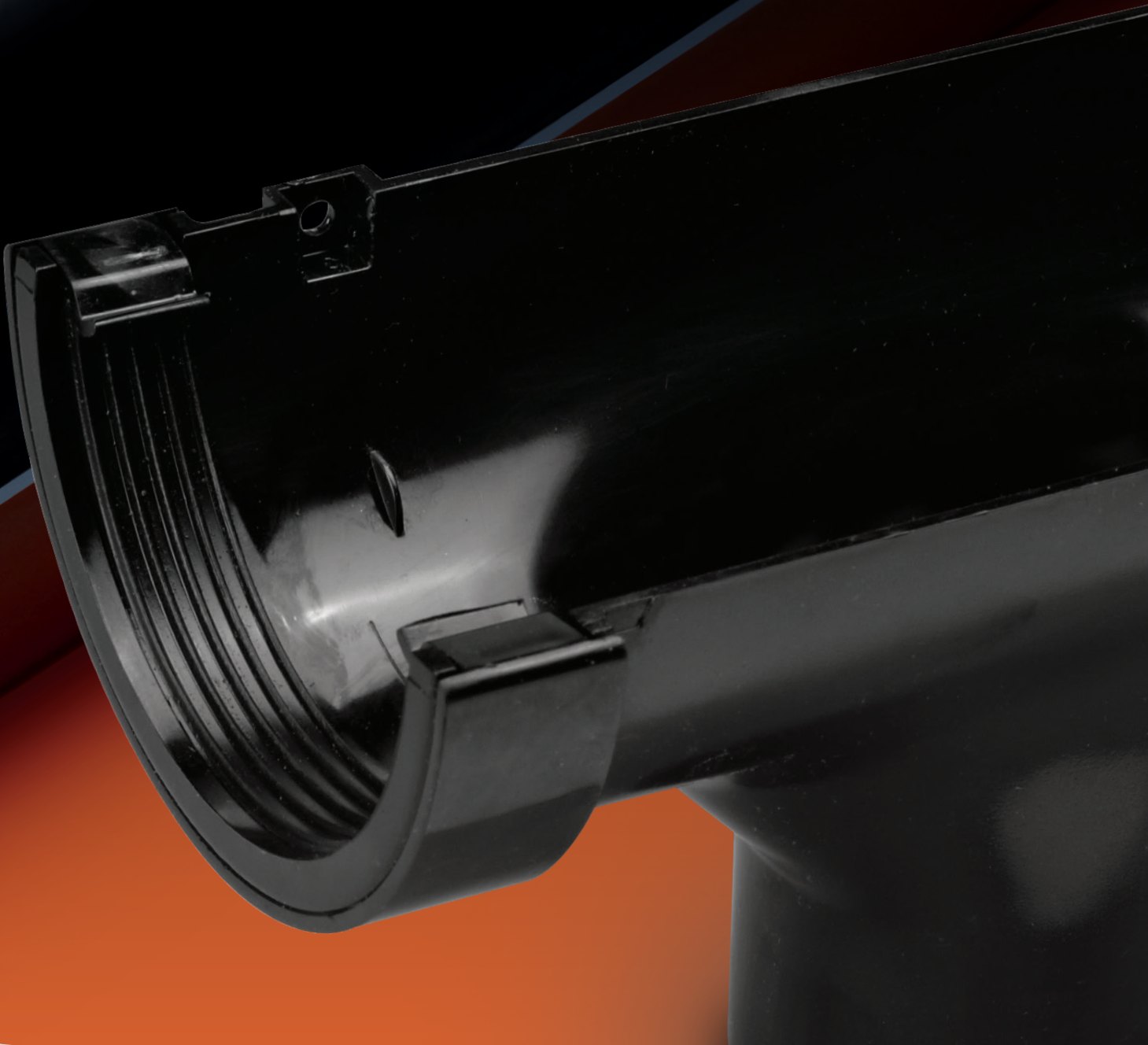

wavin

Osma Rainwater

Systems

Contents

| | | | |
|---|--------------|---|--------------|
| ⦿ Introduction to | 2-3 | ⦿ System Connections | 70-75 |
| ⦿ Selection Guidance | 4-5 | Connections to Below Ground Drainage | 70-72 |
| ⦿ Gutter Profiles and Downpipes | 6-7 | Connections to Existing Iron Pipe | 73 |
| Key Gutter Fittings | 6 | Roof Outlets | 74 |
| Key Pipe Fittings | 7 | Pipe Jointing for 82mm and 110mm pipe | 75 |
| ⦿ PVC-U Rainwater Systems | 8-48 | ⦿ Quick Reference Guide | 76-82 |
| RoundLine | 8-18 | Preparation | 76 |
| SquareLine | 19-27 | Installation Techniques | 77 |
| StormLine | 28-32 | Installation Procedures – Gutters | 78-79 |
| DeepLine NEW Anthracite Grey | 33-36 | Installation Procedures – Downpipes | 80 |
| SuperLine | 37-40 | Installation Procedures – Connections to Drainage | 81 |
| RoofLine | 41-47 | Installation Tips | 82 |
| Roof Outlets | 48 | ⦿ General Information | 83-84 |
| ⦿ Design Procedures | 49-54 | ⦿ 'How to' Videos | 84 |
| Determining Gutter Flow Capacity | 49-51 | | |
| Gutter Support | 52 | | |
| Gutter Jointing | 53 | | |
| Connections to Other Gutter Types | 53 | | |
| Pipe Support | 54 | | |
| ⦿ Design Detailing | 55-60 | | |
| Typical Connections of Gutter Outlets to Osma Pipe | 55 | | |
| Typical Connections of Gutter Outlets to Cast Iron Pipe | 56-57 | | |
| Connections to Below Ground Drainage | 58 | | |
| Roof Outlets | 58-59 | | |
| Materials: Properties and Performance | 59 | | |
| | 60 | | |
| ⦿ Transport, Handling and Storage | 61 | | |
| Handling, Storage and Safety | 61 | | |
| ⦿ General Techniques | 62-69 | | |
| Gutter Jointing | 62 | | |
| Gutter Connection to Other Materials | 63 | | |
| Gutter Support | 63 | | |
| Gutter Support – Installation Methods | 64-65 | | |
| Hints and Tips | 65 | | |
| Downpipe Cutting and Jointing | 66 | | |
| Pipe Jointing | 67 | | |
| Pipe Support and Offsets | 68 | | |
| Installation of Rainwater Diverter Kit | 69 | | |

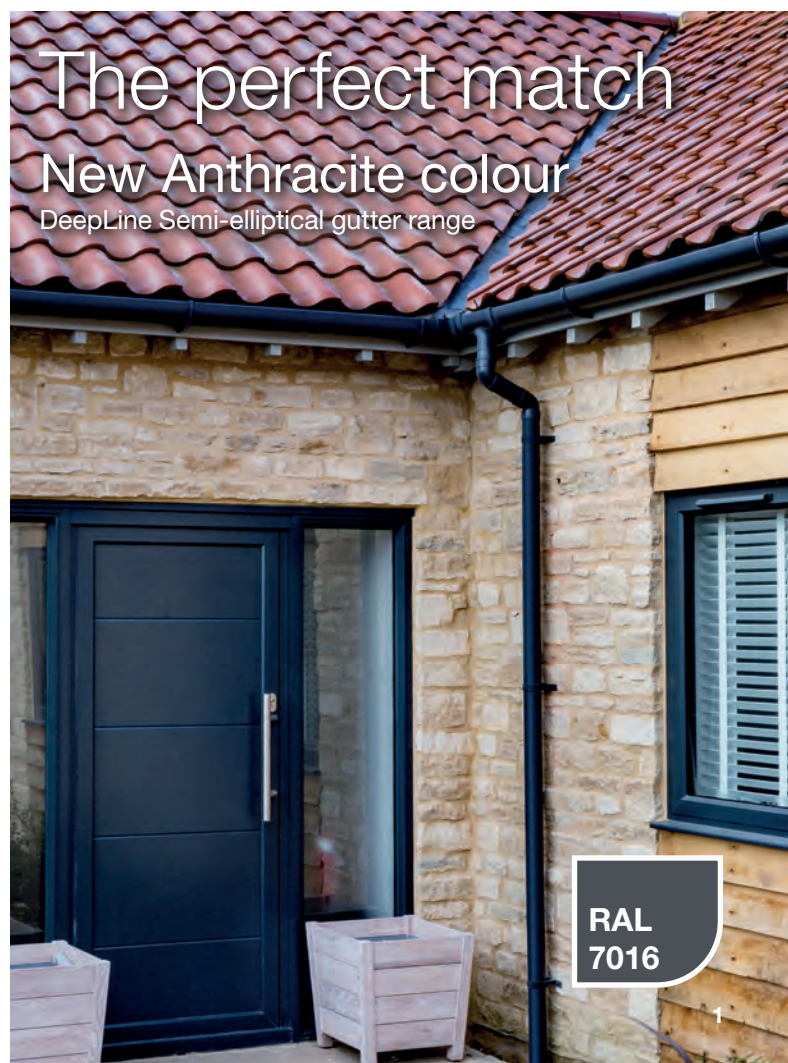

RAL
7016

Osma Rainwater Systems

Introduction to

Gutter Profiles PVC-U Rainwater System



The Osma range offers a choice of six rainwater gutter profiles to meet the varying aesthetic, performance and installation requirements for all types of building, from single dwelling to large residential, commercial or industrial premises.

In addition, Osma Domed Roof Outlets provide efficient and reliable drainage for flat roofs. These pages provide an overview of the Osma range to help specifiers select the most appropriate system for a specific project.

For flow capacities, see page 5.

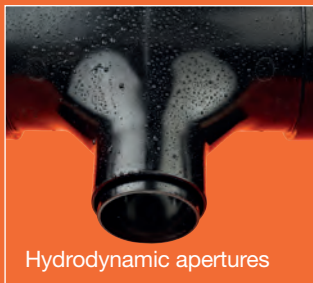

Hydrodynamic apertures

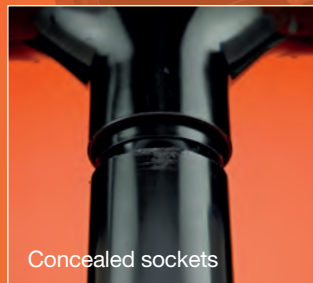

Concealed sockets

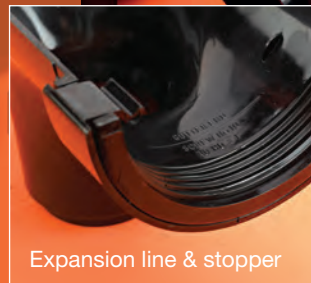

Expansion line & stopper



Wide retained seals

Outstanding flow performance

- ⊙ Hydrodynamic apertures on outlets for outstanding flow performance.

Aesthetic design details

- ⊙ Concealed sockets to hide cut ends (all systems).
- ⊙ Hanging brackets to allow clean line of guttering (StormLine).

Easy to install

- ⊙ Osma 'Flexiclip' and seal jointing mechanism makes it easy to connect gutter to fittings. Because the clip is flexed, rather than the whole component, this ensures a positive, permanently watertight joint. Gutter joint fittings are marked to indicate the limit for positioning gutter ends to allow for thermal expansion.

Specialist design features

- ⊙ Osma Stormline is an ogee profiled system with many unique features including a high front edge to catch and control runoff and stop overshoot, side fixing wings to aid installation and downpipe restraint to give a more secure hold (valuable on taller buildings).

Specialist seal technology

- ⊙ Our retained seals provide a secure, watertight fixture with the flexibility to cope with thermal expansion.

'Flexiclip' gutter joint.

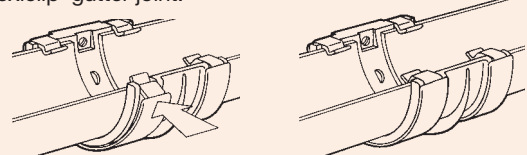

Comprehensive Choice

Domestic



RoundLine
112mm (4½")
Half-round gutter



SquareLine
100mm (4")
Square section gutter



StormLine
111x76x97mm (4¼x3¾")
Ogee profile gutter



DeepLine
113mm (4½")
Semi-elliptical gutter

Industrial & Commercial



SuperLine
125mm (5")
Half-round gutter



RoofLine
150mm (6")
Half-round gutter

| Gutters | Domestic | | Domestic High Capacity | | Industrial & Commercial | |
|--------------------|-------------------|-------------------|------------------------|-------------------|-------------------------|-------------------|
| | RoundLine | SquareLine | StormLine | DeepLine | SuperLine | RoofLine |
| Max Roof Area* | 163m ² | 178m ² | 254m ² | 299m ² | 250m ² | 317m ² |
| Downpipe Systems | 68mm ● | 61mm ■ 68mm ● † | 61mm ■ 68mm ● | 68mm ● | 68mm ● | 110mm ● |
| Width | 114mm | 103mm | 111mm | 113mm | 125mm | 150mm |
| Depth | 50mm | 51mm | 76mm | 76mm | 64mm | 74mm |
| Depth (back) | | | 97mm | | | |
| Colour Choice | ● ● ● ● ● ^ | ● ● ● | ● ● | ● ● ● ● ● | ● | ● ● |
| 1930's Semi | ● | ● | ○ | ○ | | |
| Terrace | ● | ○ | ○ | ○ | | |
| 3-Bed Detached | ○ | ● | ○ | ○ | | |
| 3-Storey Townhouse | ○ | ○ | ○ | ● | | |
| Apartment Block | ○ | ○ | ○ | ● | | |
| Luxury Detached | | | ● | ○ | | |
| Conservatory | ○ | ○ | ● | | | |
| Offices | | | | | ● | ○ |
| Barn/Agricultural | | | | | ● | ○ |
| Warehouse | | | | | ○ | ● |

● Recommended ○ Also suitable * Maximum roof area when using one downpipe † via adaptor

Note: RoundLine Anthracite Grey ^ is only available in the downpipe (to be used with DeepLine Anthracite Grey guttering system).

Approvals

BS EN 607: 2004

Eaves, gutters & fittings – PVC-U.
Definitions, requirements and testing.

Approved Systems:

RoundLine, DeepLine, SuperLine,
RoofLine, SquareLine' and StormLine.

BS EN 1462: 2004

Gutter brackets. Classification,
requirements & testing.

Approved Systems:

RoundLine, DeepLine, SuperLine.
RoofLine, SquareLine and StormLine.

BS EN 12200-1: 2000

Plastics rainwater piping systems for
above ground external use – PVC-U.

Approved Systems:

Round pipes 68, 82 and 110mm.
Square pipe 61mm. Gutter only.

Note: see product details section for individual part number approval information.

Osma Rainwater Systems

Selection Guidance

Downpipes

| Downpipes – Circular Pipe | | | | | |
|---------------------------|-------------------|-----------|----------------|----------|---|
| Nominal Size | Outside Dimension | | Wall Thickness | | System Usage |
| 68 | 68.3 min | 68.7 max | 1.8 min | 2.1 max | RoundLine, DeepLine, SuperLine and StormLine. |
| 82 | 82.4 min | 82.8 max | 3.2 min | 3.5 max | Domed Roof Outlets. |
| 110 | 110.0 min | 110.4 max | 3.2 min | 3.5 max | RoundLine and Domed Roof Outlets. |
| Downpipes – Square Pipe | | | | | |
| 61 | 60.60 min | 61.40 max | 1.45 min | 1.75 max | SquareLine and StormLine. |

(All dimensions in millimetres).

Domed Roof Outlets

82mm and 110mm Domed Roof Outlets

- ⊙ For flat roofs.
- ⊙ May be installed in mastic asphalt or built-up roofing.
- ⊙ For roof areas up to a maximum of
 - 143m² for 82mm outlet.
 - 209m² for 110mm outlet.
 with one downpipe.
- ⊙ Connects to 82mm and 110mm circular downpipe.



Selection Guidance

The next few pages provide a quick-reference system selector for typical building types (page 3). For other projects, or if you need to check capacity requirements in more detail, see roof area calculations (opposite).

NOTE: For full capacity and flowrate information, see pages 50-51.

The main factors

Rainwater system selection firstly needs to consider:

- ⊙ Volume of water to be managed by the system – this defines the required capacity of the rainwater system to be installed

Required capacity

This is determined by:

- ⊙ Type of building
- ⊙ Roof area to be drained
- ⊙ Anticipated rainfall level

NOTE: Building Regulations require allowance for a 1 in 30-year storm.

Steps to selection

System selection is decided by:

- ⊙ System capacity: its ability to handle the required capacity
- ⊙ Appearance: gutter profile shape and colour

How many brackets?

Whichever system you select, you'll need:

Gutter Support Brackets

- ⊙ 3 per 4m gutter length when using Gutter Jointing Brackets
- ⊙ 4 per 4m gutter length when using Gutter Unions

NOTE: Increase number of brackets if allowing for snow-loading

Pipe Support Brackets

- ⊙ 1 per 2m downpipe length

How long?

Downpipe

- ⊙ Standard 2-storey house: 5.5m length
- ⊙ Bungalow: 2.75m length

Selection Guidance

System capacity

This is dependent on:

- ⊙ Gutter capacity (flow in litres per second) according to size and profile shape, but also influenced by:
- ⊙ How the gutter is laid – with a gradient (FALL), or LEVEL
- ⊙ Number of outlets
- ⊙ Location of outlets – at the END, or in the CENTRE, of the gutter run

System capacity will be less:

- ⊙ If the gutter is laid level, rather than with a fall
- ⊙ If the gutter includes an angle, rather than a straight run
- ⊙ If the gutter outlet is at the end of the run rather than mid-run

For a quick-reference comparison of system capacity for each Osma system, see page 3.

If in doubt – or if your project is not a typical building/size:

- ⊙ Calculate maximum roof area to be drained
- ⊙ If you still require advice, call Wavin Technical Design.

Simplified method

- ⊙ Measure the roof plan area (A x B) in square metres
- ⊙ Multiply the area by the appropriate 'roof pitch factor'
 - Shallow (approx. 30°): 1.29
 - Normal (approx. 45°): 1.50
 - Steep (approx. 60°): 1.87

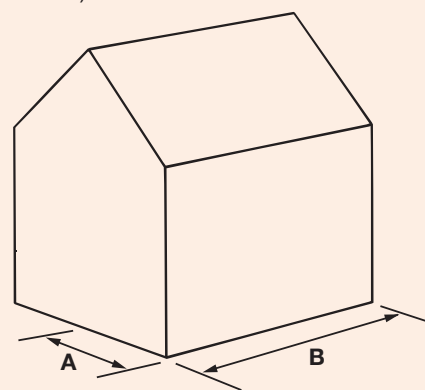

EXAMPLE:

A = 5m and B = 12m

Shallow pitch: 30°

- ⊙ Roof plan area: 5m x 12m = 60m²
- ⊙ Effective roof area: 60 x 1.29 = 77.4m²

Maximum effective roof area for each system

Having calculated the effective roof area to be drained:

- ⊙ Check which Osma systems have sufficient capacity

Maximum Effective Roof Area (m²) gutter laid to 1:600 fall

| Running outlet position | | | |
|-------------------------|------------------|---------------------|--------------------------|
| System | At END of gutter | At CENTRE of gutter | Flow capacity litres/sec |
| RoundLine | 79 | 163 | 1.25-3.43 |
| SquareLine | 96 | 178 | 1.30-3.71 |
| StormLine ■ | 130 | 254 | 1.32-5.28 |
| StormLine ● | 125 | 239 | 1.26-4.98 |
| DeepLine | 145 | 299 | 2.28-6.21 |
| SuperLine | 121 | 250 | 2.10-5.19 |
| RoofLine | 164 | 317 | 2.48-6.59 |

NOTE: System capacity/performance capability is reduced if the roof includes valleys, dorma windows, steep pitch, or Guttering is laid level (reduction approx. 20-30%), or Gutter includes an angle (reduction approx. 15%). ■ With SquareLine downpipe ● With RoundLine downpipe

Osma Rainwater

Gutter Profiles and Downpipes

Key Gutter Fittings

| | | Size (mm) | Colour | Joining | Bracket | Union | Brackets | Support | Rise and Fall | Rafter | Rafter (Adjustable) | Hanging | Connectors | (See KEY*) | Outlets | Running | Stopend | Angles | 90° | 60° | 45° |
|--------------------------------|--------------|-----------|--------|---------|---------|-------|----------|---------|---------------|--------|---------------------|---------|------------|------------|---------|---------|---------|--------|-----|-----|-----|
| Half-round Gutter Systems | RoundLine | 112 | | | ■ | ■ | | ■ | ■ | ■ | ■ | - | | a b | | ■ | ■ | | ■ | ■ | ■ |
| | SuperLine | 125 | | | - | ■ | | ■ | ■ | ■ | ■ | - | | - | | ■ | - | | ■ | - | ■ |
| | RoofLine | 150 | | | - | ■ | | ■ | ■ | ■ | ■ | - | | - | | ■ | - | | ■ | - | - |
| Semi-elliptical Gutter System | DeepLine | 112 | | | - | ■ | | ■ | ■ | - | ■ | - | | - | | ■ | - | | ■ | - | ■ |
| Square/Profiled Gutter Systems | SquareLine | 100 | | | ■ | ■ | | ■ | ■ | - | ■ | - | | c | | ■ | ■ | | ■ | - | ■ |
| | StormLine | 111 x 97 | | | - | ■ | | ■ | ■ | - | - | ■ | | - | | ■ | ■ | | ■ | - | ■ |
| Flat Roof and Balcony System | Roof Outlets | - | | | - | - | | - | - | - | - | - | | - | | - | - | | - | - | - |

Key*

Gutter Connectors

- a Connector to 4" or 4½" cast-iron half-round gutter
- b Connector to 4½" cast-iron ogee gutter
 - L/H and R/H versions
- c Connector to 4½" RoundLine Gutter

Pipe Connectors and Adaptors

- d Pipe Connector
- e Connector to 2½" cast-iron rainwater pipe
- f Connector to 82mm PVC-U Drain Socket
- g Rainwater Adaptor – 68mm pipe to 110mm PVC-U drain
- h Universal Drain Adaptor
- i Pipe Connector and Bracket
- j Pipe Connector and Bracket – Stand Off
- k Drain Adaptor – Square-to-Round
- l Outlet Adaptor – Square-to-Round

Reducer

- r S/S Reducer

Key to Symbols

- Standard
- ▲ Stand Off Bracket
- * Via Square-to-Round Outlet Adaptor

Note: RoundLine Anthracite Grey[▲] is only available in the downpipe (to be used with DeepLine Anthracite Grey guttering system).

Key Pipe Fittings

| | Circular Pipe | 55mm | 68mm | 82mm | 110mm | Square Pipe | 61mm | Brackets | Pipe | Socket | Pipe or Socket | Drive-in | Ext./Spacer | Connectors | (See KEY*) | Bends | Offset | Long Tail Offset | 87.5° | Branches | 67.5° | 87.5° | Access | Access Pipe |
|--------|---------------|------|------|------|-------|-------------|------|----------|------|--------|----------------|----------|-------------|------------|------------------|-------|--------|------------------|-------|----------|-------|-------|--------|-------------|
| | - | ■ | - | - | | - | | ■ | ■ | ■ | ■ | ■ | ■ | | d e f g h | | ■ | ■ | ■ | | ■ | - | | ■ |
| | - | ■ | - | - | | - | | ■ | ■ | ■ | ■ | ■ | ■ | | d e f g h | | ■ | ■ | ■ | | ■ | - | | ■ |
| | - | - | - | ■ | | - | | ■ | ■ | ■ | - | - | | | r | | ■ | - | - | | ■ | ■ | | - |
| | - | ■ | - | - | | - | | ■ | ■ | ■ | ■ | ■ | ■ | | d e f g h | | ■ | ■ | ■ | | ■ | - | | ■ |
| | - | ■* | - | - | | ■ | | ■ | ■ | - | - | ■▲ | | | f g h i j k l | | ■ | - | ■ | | ■ | - | | ■ |
| Square | - | - | - | - | | ■ | | ■ | ■ | - | - | ■▲ | | | f g h i j k l | | ■ | - | ■ | | ■ | - | | ■ |
| Round | - | ■ | - | - | | - | | ■ | ■ | ■ | ■ | ■ | | | | | | | | | | | | |
| | - | - | ■ | ■ | | - | | ■ | ■ | ■ | - | - | | | - | | ■ | - | - | | ■ | ■ | | - |

Colour Key

| Colour | Ref. Code |
|-----------------|-----------|
| Black | ● |
| Grey | ● |
| White | ○ |
| Brown | ● |
| Anthracite Grey | ● |

RoundLine

Product Details **PVC-U Rainwater Systems**

Gutter



RoundLine Gutter

Material: PVC-U

| Nominal Size (mm) | Part Number | Colour Option | Length (m) |
|-------------------|-------------|---------------|------------|
| 112 | OT072 | ● ● ○ ● | 2 |
| 112 | OT074 | ● ● ○ ● | 4 |

Gutter Union and Brackets

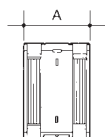

Gutter Jointing Bracket

- Used to join running lengths of gutter and fixing to fascia

Material: PVC-U, with EPDM seals

| Nominal Size (mm) | Part Number | Colour Option | Dimensions (mm) A |
|-------------------|-------------|---------------|-------------------|
| 112 | OT005 | ● ● ○ ● | 97 |

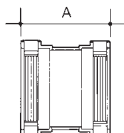

Gutter Union

- Use with Gutter Support Brackets OT019, Top/Side Rafter Brackets or Rise-and-Fall Brackets

Material: PVC-U, with EPDM seals

| Nominal Size (mm) | Part Number | Colour Option | Dimensions (mm) A |
|-------------------|-------------|---------------|-------------------|
| 112 | OT009 | ● ● ○ ● | 105 |

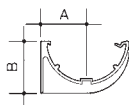

Gutter Support Bracket

- For support centres, see page 54

Material: PVC-U

| Nominal Size (mm) | Part Number | Colour Option | Dimensions (mm) | |
|-------------------|-------------|---------------|-----------------|----|
| | | | A | B |
| 112 | OT019 | ● ● ○ ● | 67 | 73 |



Gutter Bracket Spacer – 21mm Projection

- Use with Support Brackets OT019 to provide additional 21mm clearance
- Up to two bracket spacers can be stacked

Material: PVC-U

| Nominal Size (mm) | Part Number | Colour Option | Dimensions (mm) | |
|-------------------|-------------|---------------|-----------------|----|
| | | | A | B |
| – | OT044 | ● | 103 | 21 |

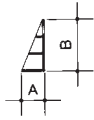

Angled Bracket Spacer

- 22.5° angle
- Use with Support Bracket 0T019 when fascia board or rafter/truss ends are angled

Material: PVC-U

| Nominal Size (mm) | Part Number | Colour Option | Dimensions (mm) | |
|-------------------|-------------|---------------|-----------------|----|
| | | | A | B |
| - | 0T045 | ● | 33 | 74 |

Outlets and Stopends

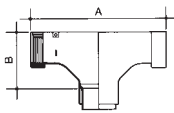

Running Outlet – straight

- For gutter capacity, see pages 5 and 49-51
- Outlet for 68mm pipe

Material: PVC-U, with EPDM seals

| Nominal Size (mm) | Part Number | Colour Option | Dimensions (mm) | |
|-------------------|-------------|---------------|-----------------|-----|
| | | | A | B |
| 112 | 0T624 ♡ | ● ○ ● | 257 | 105 |

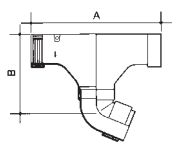

Swivelock Running Outlet – with Fitted 67.5° Offset Bend

- Maximum fascia depth 138mm
- For gutter capacity, see pages 5 and 49-51
- Outlet for 68mm pipe

Material: PVC-U, with EPDM seals

| Nominal Size (mm) | Part Number | Colour Option | Dimensions (mm) | |
|-------------------|-------------|---------------|-----------------|-----|
| | | | A | B |
| 112 | 0T625 ♡ | ● | 257 | 155 |

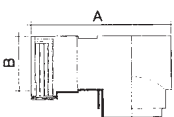

Stopend Outlet

- For gutter capacity, see pages 5 and 49-51
- Outlet for 68mm pipe

Material: PVC-U, with EPDM seal

| Nominal Size (mm) | Part Number | Colour Option | Dimensions (mm) | |
|-------------------|-------------|---------------|-----------------|----|
| | | | A | B |
| 112 | 0T007 ♡ | ● ○ ● | 148 | 56 |



Internal Stopend

Material: PVC-U

| Nominal Size (mm) | Part Number | Colour Option | Dimensions (mm) |
|-------------------|-------------|---------------|-----------------|
| | | | A |
| 112 | 0T010 ♡ | ● ○ ● | 33 |

RoundLine

Product Details **PVC-U Rainwater Systems**



External Stopend

Material: PVC-U, with EPDM seal

| Nominal Size (mm) | Part Number | Colour Option | Dimensions (mm) | |
|-------------------|-------------|---------------|-----------------|--|
| | | | A | |
| 112 | 0T011 | ● ○ ● | 30 | |

Gutter Angles

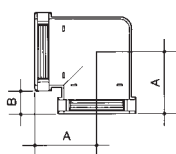

90° Angle

Material: PVC-U, with EPDM seals

| Nominal Size (mm) | Part Number | Colour Option | Dimensions (mm) | |
|-------------------|-------------|---------------|-----------------|----|
| | | | A | B |
| 112 | 0T003 | ● ○ ● | 106 | 47 |

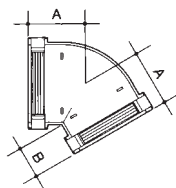

60° Angle

Material: PVC-U, with EPDM seals

| Nominal Size (mm) | Part Number | Colour Option | Dimensions (mm) | |
|-------------------|-------------|---------------|-----------------|----|
| | | | A | B |
| 112 | 0T016 | ● | 82 | 48 |

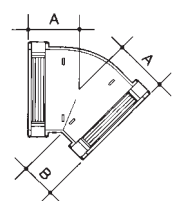

45° Angle

Material: PVC-U, with EPDM seals

| Nominal Size (mm) | Part Number | Colour Option | Dimensions (mm) | |
|-------------------|-------------|---------------|-----------------|----|
| | | | A | B |
| 112 | 0T004 | ● ○ ● | 71 | 48 |

Fabricated Angles

- Angles fabricated to order
- For details, contact Technical Design Department

Material: PVC-U, with EPDM seals

| Nominal Size (mm) | Part Number | Colour Option | Dimensions (mm) | |
|-------------------|-------------|---------------|-----------------|---|
| | | | A | B |
| 112 | 0T999 | ● ○ ● | | |

Leaf Guard



For installation tips see:

YouTube
WavinUK

Leaf Guard

- Plastic mesh designed to fit into 112mm gutter to prevent blocking by leaves and debris
- Pack contains 10 x 500mm lengths

Material: Recycled plastic

| Nominal Size (mm) | Part Number | Colour Option | Dimensions (mm) | |
|-------------------|-------------|---------------|-----------------|-----|
| | | | A | B |
| 112 | OT017 | ● | 500 | 108 |

Connectors to Metal and PVC-U Gutters

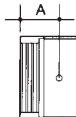

Connector to 4" or 4.5" Cast-Iron Half-Round Gutter

- Use with waterproof mastic

Material: PVC-U, with EPDM seal

| Nominal Size (mm) | Part Number | Colour Option | Dimensions (mm) | |
|-------------------|-------------|---------------|-----------------|--|
| | | | A | |
| 112 | OT008 ♡ | ● | 54 | |

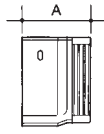

Connector to 4.5" Cast-Iron Ogee Gutter

- Use with waterproof mastic

Material: PVC-U, with EPDM seal

| Nominal Size (mm) | Part Number | Colour Option | Dimensions (mm) | |
|-------------------|-------------|---------------|-----------------|--|
| | | | A | |
| 112 LH | OT014 ♡ | ● | 97 | |
| 112 RH | OT015 ♡ | ● | 97 | |

Rise and Fall Brackets and Spikes

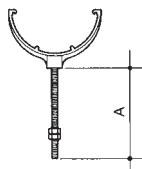

Bow and Pin for Rise and Fall Brackets

- Use with Spikes OT985/986 or OT988/989
- Diameter of rod: 8mm

Material: Pin – Stainless steel; Bracket – PVC-U

| Nominal Size (mm) | Part Number | Colour Option | Dimensions (mm) | |
|-------------------|-------------|---------------|-----------------|--|
| | | | A | |
| 112 | OT914 | ● ○ ● | 115 | |

RoundLine

Product Details **PVC-U Rainwater Systems**

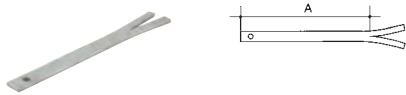

Build-in Spikes

Material: Galvanised mild steel

| Nominal Size (mm) | Part Number | Dimensions (mm) | |
|-------------------|-------------|-----------------|--------|
| | | A | Length |
| - | 0T985 | 160 | 230 |
| - | 0T986 | 260 | 330 |

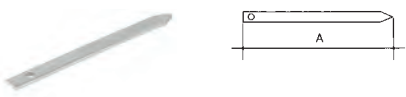

Drive-in Spikes

Material: Galvanised mild steel

| Nominal Size (mm) | Part Number | Dimensions (mm) |
|-------------------|-------------|-----------------|
| | | A |
| - | 0T988 | 230 |
| - | 0T989 | 330 |

Rafter Brackets



Top Rafter Bracket

- Angle of bracket: 30°

Material: PVC-coated steel

| Nominal Size (mm) | Part Number | Colour Option | Dimensions (mm) |
|-------------------|-------------|---------------|-----------------|
| | | | A |
| 112 | 0T745 | ● | 300 |



Side Rafter Bracket

- Angle of bracket: 30°

Material: PVC-coated steel

| Nominal Size (mm) | Part Number | Colour Option | Dimensions (mm) |
|-------------------|-------------|---------------|-----------------|
| | | | A |
| 112 | 0T746 | ● | 300 |

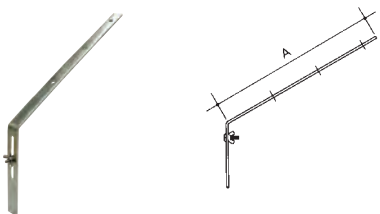

Adjustable Top Rafter Bracket

- Use with Gutter Support Bracket 0T019
- Angle of bracket: 30°

Material: BZP-plated steel

| Nominal Size (mm) | Part Number | Dimensions (mm) |
|-------------------|-------------|-----------------|
| | | A |
| - | 0T147 | 300 |

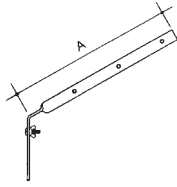

Adjustable Side Rafter Bracket

- Use with Gutter Support Bracket OT019
- Angle of bracket: 30°

Material: BZP-plated steel

| Nominal Size (mm) | Part Number | Dimensions (mm) A |
|-------------------|-------------|-------------------|
| - | OT148 | 300 |

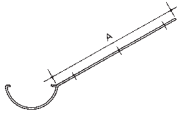

Top Rafter Bracket

- Angle of bracket: 30°

Material: Galvanised mild steel

| Nominal Size (mm) | Part Number | Dimensions (mm) A |
|-------------------|-------------|-------------------|
| 112 | OT245 | 300 |

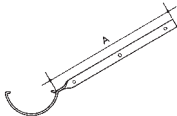

Side Rafter Brackets

- Angle of bracket: 30°

Material: Galvanised mild steel

| Nominal Size (mm) | Part Number | Dimensions (mm) A |
|-------------------|-------------|-------------------|
| 112 | OT246 | 300 |

Pipe



P/E Pipe

Material: PVC-U

| Nominal Size (mm) | Part Number | Colour Option | Length (m) |
|-------------------|-------------|---------------|------------|
| 68 | OT082 ♡ | ● ● ● | 2.0 |
| 68 | OT086 ♡ | ● ● ○ ● ● | 2.75 |
| 68 | OT084 ♡ | ● ● ○ ● ● | 4.0 |
| 68 | OT088 ♡ | ● ● ○ ● ● | 5.5 |

RoundLine

Product Details **PVC-U Rainwater Systems**

Pipe and Socket Brackets

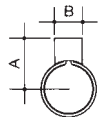

Pipe or Socket Bracket

- For pipe support centres, see page 54
- Use outside grooves for sockets

Material: PVC-U

| Nominal Size (mm) | Part Number | Colour Option | Dimensions (mm) | |
|-------------------|-------------|---------------|-----------------|----|
| | | | A | B |
| 68 | 0T033 ♡ | ● ● ○ ● | 71 | 38 |

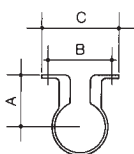

Pipe Bracket

- For pipe support centres, see page 54

Material: PVC-U

| Nominal Size (mm) | Part Number | Colour Option | Dimensions (mm) | | |
|-------------------|-------------|---------------|-----------------|----|-----|
| | | | A | B | C |
| 68 | 0T034 ♡ | ● ● ○ ● ● | 72 | 90 | 110 |

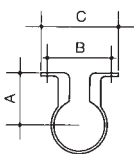

Socket Bracket

- Use with Pipe Connector 0T024, 67.5° Branch 0T035, Pipe Shoe 0T037, 87.5° Bend 0T161, Access Pipe 0T274
- For pipe support centres, see page 54

Material: PVC-U

| Nominal Size (mm) | Part Number | Colour Option | Dimensions (mm) | | |
|-------------------|-------------|---------------|-----------------|----|-----|
| | | | A | B | C |
| 68 | 0T038 ♡ | ● ● ○ ● ● | 72 | 90 | 110 |

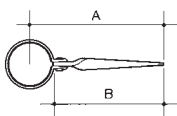

Drive-in Pipe Bracket

- For pipe support centres, see page 54

Material: Spike – Galvanised steel; Bracket – PVC-U

| Nominal Size (mm) | Part Number | Colour Option | Dimensions (mm) | |
|-------------------|-------------|---------------|-----------------|-----|
| | | | A | B |
| 68 | 0T143 ♡ | ● | 206 | 171 |

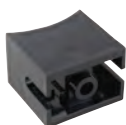

Pipe Bracket Spacer

- Use with Pipe or Socket Bracket 0T033 as a spacer

Material: PVC-U

| Nominal Size (mm) | Part Number | Colour Option |
|-------------------|-------------|---------------|
| | | |

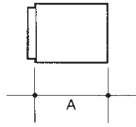

Bracket Extension Piece

- Use with Pipe or Socket Bracket 0T033 as a spacer
- Adds a maximum of 45mm to the wall-to-pipe centre dimension
- Can be cut to suit

Material: PVC-U

| Nominal Size (mm) | Part Number | Colour Option | Dimensions (mm) | |
|-------------------|-------------|---------------|-----------------|--|
| | | | A | |
| 68 | 0T030 ♡ | ● | 45 | |

Connectors and Adaptors

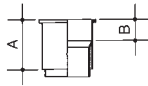

Pipe Connector

- Support with Socket Bracket 0T038

Material: PVC-U

| Nominal Size (mm) | Part Number | Colour Option | Dimensions (mm) | |
|-------------------|-------------|---------------|-----------------|----|
| | | | A | B |
| 68 | 0T024 ♡ | ● ○ ● ● | 70 | 30 |

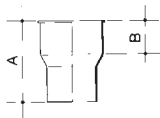

Connector to 2.5 " Cast-Iron Rainwater Pipe

- Use with Pipe Connector 0T024
- Support with Socket Bracket 0T038

Material: PVC-U

| Nominal Size (mm) | Part Number | Colour Option | Dimensions (mm) | |
|-------------------|-------------|---------------|-----------------|----|
| | | | A | B |
| 68 | 0T092 ♡ | ● | 110 | 45 |

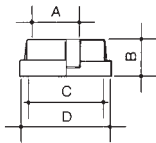

Rainwater Adaptor

- 68mm pipe to 110mm PVC-U drain
- External use only
- For use with 110mm drain socket or spigot

Material: Polypropylene

| Nominal Size (mm) | Part Number | Colour Option | Dimensions (mm) | | | |
|-------------------|-------------|---------------|-----------------|----|-----|-----|
| | | | A | B | C | D |
| - | 4S149 | | 69 | 55 | 110 | 132 |
| - | 0T149 ♡ | ● | 69 | 55 | 110 | 132 |

RoundLine

Product Details **PVC-U Rainwater Systems**

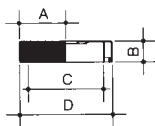

Universal Drain Adaptor

- For external use only
- For 110mm drain socket or spigot

Material: EPDM

| Nominal Size (mm) | Part Number | Colour Option | Dimensions (mm) | | | |
|-------------------|-------------|---------------|-----------------|----|-----|-----|
| | | | A | B | C | D |
| - | 4S159 | ● | 68 | 30 | 110 | 136 |

Bends and Shoe

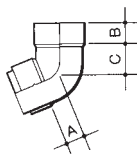

Offset Bend – Socket

- 67.5° offset. Minimum achievable offset: 90mm
- For use as top or bottom bend

Material: PVC-U

| Nominal Size (mm) | Part Number | Colour Option | Dimensions (mm) | | |
|-------------------|-------------|---------------|-----------------|----|----|
| | | | A | B | C |
| 68 | 0T025 ♡ | ● ○ ● ● | 29 | 30 | 40 |

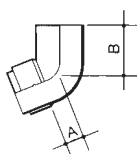

Offset Bend – Spigot

- 67.5° offset. Spigot may be cut back by 20mm to achieve 70mm offset
- For use as top or bottom bend
- Use with Offset Bend 0T025, or Running Outlets 0T624/625

Material: PVC-U

| Nominal Size (mm) | Part Number | Colour Option | Dimensions (mm) | |
|-------------------|-------------|---------------|-----------------|----|
| | | | A | B |
| 68 | 0T026 ♡ | ● ○ ● ● | 30 | 70 |

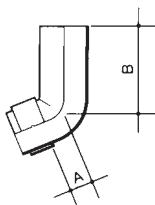

Long Tail Offset Bend – Spigot

- 67.5° offset
- Use with Straight Running Outlet 0T624

Material: PVC-U

| Nominal Size (mm) | Part Number | Colour Option | Dimensions (mm) | |
|-------------------|-------------|---------------|-----------------|-----|
| | | | A | B |
| 68 | 0T027 ♡ | ● | 46 | 122 |

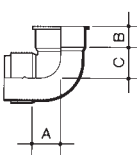

Pipe Bend – 87.5°

- Use with Socket Bracket 0T038

Material: PVC-U

| Nominal Size (mm) | Part Number | Colour Option | Dimensions (mm) | | |
|-------------------|-------------|---------------|-----------------|----|----|
| | | | A | B | C |
| 68 | 0T161 ♡ | ● ○ ● ● | 39 | 30 | 40 |

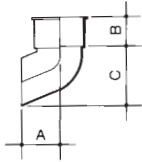

Pipe Shoe

- Use with Socket Bracket 0T038

Material: PVC-U

| Nominal Size (mm) | Part Number | Colour Option | Dimensions (mm) | | |
|-------------------|-------------|---------------|-----------------|----|----|
| | | | A | B | C |
| 68 | 0T037 | ● ○ ● ● | 40 | 30 | 83 |

Branch, Access Pipe and Hopper Head

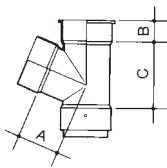

Pipe Branch – 67.5°

- Use with Socket Bracket 0T038

Material: PVC-U

| Nominal Size (mm) | Part Number | Colour Option | Dimensions (mm) | | |
|-------------------|-------------|---------------|-----------------|----|----|
| | | | A | B | C |
| 68 | 0T035 | ● ○ ● ● | 62 | 30 | 93 |

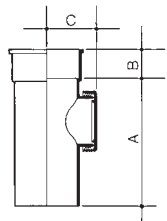

Access Pipe with Screwed Door

- Use with Socket Bracket 0T038

Material: PVC-U

| Nominal Size (mm) | Part Number | Colour Option | Dimensions (mm) | | |
|-------------------|-------------|---------------|-----------------|----|----|
| | | | A | B | C |
| 68 | 0T274 | ● ○ ● ● | 135 | 30 | 50 |

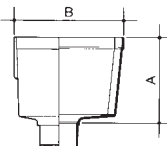

Hopper Head

- Flow capacity 2.40 l/s
- Spigot sized for 68mm pipe

Material: PVC-U

| Nominal Size (mm) | Part Number | Colour Option | Dimensions (mm) | | |
|-------------------|-------------|---------------|-----------------|-----|-------|
| | | | A | B | Width |
| 68 | 0T332 | ● ○ ● ● | 130 | 178 | 255 |

Rainwater Diverter Kit

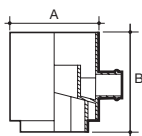

Rainwater Diverter Kit

- Provides an outlet to allow a waterbutt to be filled from a downpipe

Material: PVC-U; Connector – Polypropylene; Seal – EPDM

| Nominal Size (mm) | Part Number | Colour Option | Dimensions (mm) | |
|-------------------|-------------|---------------|-----------------|----|
| | | | A | B |
| 68 | 0T201 | ● ○ | 76 | 87 |

RoundLine

Product Details **PVC-U Rainwater Systems**

Spares



Gutter Seal





Material: EPDM

| Nominal Size (mm) | Part Number |
|-------------------|-------------|
| 112 | 0T064 |



Flexiclip

Material: PVC-U

| Nominal Size (mm) | Part Number | Colour Option |
|-------------------|---|---|
| 112 | 0T116  |     |



Gutter Pad – Narrow

- For 'old style' gutter joints – not flexiclip joints
- To glue in seals use waterproof contact adhesive

Material: EPDM

| Nominal Size (mm) | Part Number |
|-------------------|-------------|
| 112 | 0T060 |



Gutter Pad – Wide

- For 'old style' gutter joints – not flexiclip joints
- To glue in seals use waterproof contact adhesive

Material: EPDM

| Nominal Size (mm) | Part Number |
|-------------------|-------------|
| 112 | 0T061 |

SquareLine

PVC-U Rainwater Systems

Gutter



SquareLine Gutter

Material: PVC-U

| Nominal Size (mm) | Part Number | Colour Option | Length (m) |
|-------------------|-------------|---------------|------------|
| 100 | 4T872 | ● ○ ● | 2 |
| 100 | 4T874 | ● ○ ● | 4 |

Gutter Union and Brackets

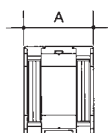

Gutter Jointing Bracket

- Used to join running lengths of gutter and fixing to fascia

Material: PVC-U, with EPDM seals

| Nominal Size (mm) | Part Number | Colour Option | Dimensions (mm) A |
|-------------------|-------------|---------------|-------------------|
| 100 | 4T805 | ● ○ ● | 99 |

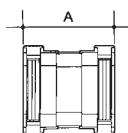

Gutter Union

- Use with Gutter Support Bracket 4T819 (see below) or with Adjustable Top/Side Rafter Brackets, Rise-and-Fall Brackets (pages 21-22)

Material: PVC-U, with EPDM seals

| Nominal Size (mm) | Part Number | Colour Option | Dimensions (mm) A |
|-------------------|-------------|---------------|-------------------|
| 100 | 4T809 | ● ○ ● | 128 |

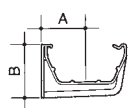

Gutter Support Bracket – 3 Screw Fixing

- For support centres, see page 54

Material: PVC-U

| Nominal Size (mm) | Part Number | Colour Option | Dimensions (mm) | |
|-------------------|-------------|---------------|-----------------|----|
| | | | A | B |
| 100 | 4T819 | ● ○ ● | 64 | 76 |



Gutter Bracket Spacer – 21mm Projection

- Use with Support Bracket 4T819 to provide additional 21mm clearance

Material: PVC-U

| Nominal Size (mm) | Part Number | Colour Option | Dimensions (mm) | |
|-------------------|-------------|---------------|-----------------|----|
| | | | A | B |
| – | 0T044 | ● | 103 | 21 |

SquareLine

PVC-U Rainwater Systems

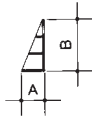

Angled Bracket Spacer

- 22.5° angle
- Use with Support Bracket 4T819 when fascia board or rafter/truss ends are angled

Material: PVC-U

| Nominal Size (mm) | Part Number | Colour Option | Dimensions (mm) | |
|-------------------|-------------|---------------|-----------------|----|
| | | | A | B |
| - | 0T045 | ● | 33 | 74 |

Outlets and Stopends

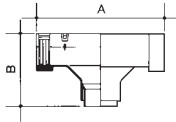

Running Outlet

- For gutter capacity, see pages 5 and 49-51
- Outlet for 61mm square pipe
- Can be adapted for use with 68mm circular pipe

Material: PVC-U, with EPDM seals

| Nominal Size (mm) | Part Number | Colour Option | Dimensions (mm) | |
|-------------------|-------------|---------------|-----------------|----|
| | | | A | B |
| 100 | 4T806 ♡ | ● ○ ● | 220 | 95 |

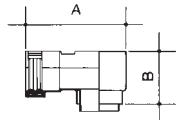

Stopend Outlet

- For gutter capacity, see pages 5 and 49-51
- Outlet for 61mm square pipe
- Can be adapted for use with 68mm circular pipe
- Use with Support Bracket 4T819

Material: PVC-U, with EPDM seal

| Nominal Size (mm) | Part Number | Colour Option | Dimensions (mm) | |
|-------------------|-------------|---------------|-----------------|----|
| | | | A | B |
| 100 | 4T807 ♡ | ● ○ ● | 142 | 55 |



Internal Stopend

Material: PVC-U

| Nominal Size (mm) | Part Number | Colour Option | Dimensions (mm) |
|-------------------|-------------|---------------|-----------------|
| | | | A |
| 100 | 4T810 ♡ | ● ○ ● | 35 |



External Stopend

Material: PVC-U, with EPDM seal

| Nominal Size (mm) | Part Number | Colour Option | Dimensions (mm) |
|-------------------|-------------|---------------|-----------------|
| | | | A |
| 100 | 4T811 ♡ | ● ○ ● | 28 |

Gutter Angles

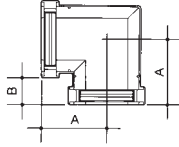

90° Angle

Material: PVC-U, with EPDM seals

| Nominal Size (mm) | Part Number | Colour Option | Dimensions (mm) | |
|-------------------|-------------|---------------|-----------------|----|
| | | | A | B |
| 100 | 4T803 | ● ○ ● | 109 | 50 |

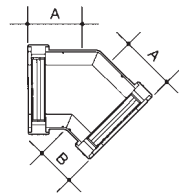

45° Angle

Material: PVC-U, with EPDM seals

| Nominal Size (mm) | Part Number | Colour Option | Dimensions (mm) | |
|-------------------|-------------|---------------|-----------------|----|
| | | | A | B |
| 100 | 4T804 | ● ○ ● | 77 | 55 |

Connectors to PVC-U Gutters

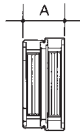

Connector to 4.5" RoundLine Gutter

Material: PVC-U, with EPDM seal

| Nominal Size (mm) | Part Number | Colour Option | Dimensions (mm) |
|-------------------|-------------|---------------|-----------------|
| | | | A |
| 100 | 4T818 | ● ○ | 56 |

Rise and Fall Brackets and Spikes

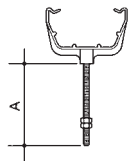

Bow and Pin for Rise and Fall Brackets

- Use with Spikes 0T985/986 or 0T988/989
- Diameter of rod: 8mm

Material: Pin – Stainless steel; Bracket – PVC-U

| Nominal Size (mm) | Part Number | Colour Option | Dimensions (mm) |
|-------------------|-------------|---------------|-----------------|
| | | | A |
| 100 | 4T894 | ● | 115 |

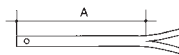

Build-in Spikes

Material: Galvanised mild steel

| Nominal Size (mm) | Part Number | Dimensions (mm) | |
|-------------------|-------------|-----------------|--------|
| | | A | Length |
| – | 0T985 | 160 | 230 |
| – | 0T986 | 260 | 330 |

SquareLine

PVC-U Rainwater Systems

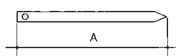

Drive-in Spikes

Material: Galvanised mild steel

| Nominal Size (mm) | Part Number | Dimensions (mm) A |
|-------------------|-------------|-------------------|
| – | 0T988 | 230 |
| – | 0T989 | 330 |

Rafter Brackets

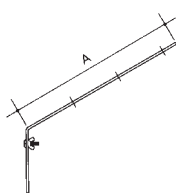

Adjustable Top Rafter Bracket

- Use with Gutter Support Bracket 4T819
- Angle of bracket: 30°

Material: BZP-plated steel

| Nominal Size (mm) | Part Number | Dimensions (mm) A |
|-------------------|-------------|-------------------|
| – | 0T147 | 300 |

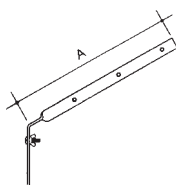

Adjustable Side Rafter Bracket

- Use with Gutter Support Bracket 4T819
- Angle of bracket: 30°

Material: BZP-plated steel

| Nominal Size (mm) | Part Number | Dimensions (mm) A |
|-------------------|-------------|-------------------|
| – | 0T148 | 300 |

Pipe



P/E Pipe

Material: PVC-U

| Nominal Size (mm) | Part Number | Colour Option | Length (m) |
|-------------------|-------------|---------------|------------|
| 61 | 4T882 ♡ | ● ○ ● | 2.0 |
| 61 | 4T886 ♡ | ● ○ ● | 2.75 |
| 61 | 4T884 ♡ | ● ○ ● | 4.0 |
| 61 | 4T888 ♡ | ● ○ ● | 5.5 |

Pipe Brackets and Spacer

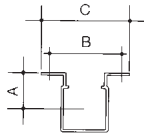

Pipe Bracket – Stand Off

- For pipe support centres, see page 54

Material: PVC-U

| Nominal Size (mm) | Part Number | Colour Option | Dimensions (mm) | | |
|-------------------|-------------|---------------|-----------------|-----|-----|
| | | | A | B | C |
| 61 | 4T833 | ● ○ ● | 51 | 100 | 127 |

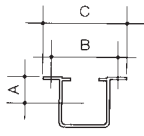

Pipe Bracket

- For pipe support centres, see page 54

Material: PVC-U

| Nominal Size (mm) | Part Number | Colour Option | Dimensions (mm) | | |
|-------------------|-------------|---------------|-----------------|----|-----|
| | | | A | B | C |
| 61 | 4T834 | ● ○ ● | 35 | 95 | 115 |

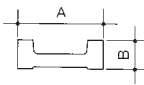

Pipe Bracket Spacer

- Use as a spacer with Pipe Connector and Bracket 4T823 Pipe Shoe and Bracket 4T832, Pipe Bracket 4T834, Access Pipe 4T855 and Wall Offset Pipe with Access 4T858
- Adds a maximum of 39mm to the wall-to-pipe centre dimension
- Can be cut to suit

Material: PVC-U

| Nominal Size (mm) | Part Number | Colour Option | Dimensions (mm) | |
|-------------------|-------------|---------------|-----------------|----|
| | | | A | B |
| 61 | 4T731 | ● ○ | 121 | 39 |

Connectors and Adaptors

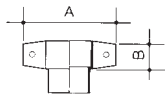

Pipe Connector and Bracket – Stand Off

Material: PVC-U

| Nominal Size (mm) | Part Number | Colour Option | Dimensions (mm) | |
|-------------------|-------------|---------------|-----------------|----|
| | | | A | B |
| 61 | 4T824 | ● ○ ● | 127 | 33 |

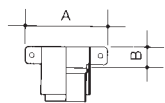

Pipe Connector and Bracket

Material: PVC-U

| Nominal Size (mm) | Part Number | Colour Option | Dimensions (mm) | |
|-------------------|-------------|---------------|-----------------|----|
| | | | A | B |
| 61 | 4T823 | ● ○ ● | 115 | 30 |

SquareLine

PVC-U Rainwater Systems

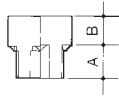

Drain Adaptor – Square to Round

- Allows 61mm square pipe to be connected to 68mm (round) Rainwater Adaptor 4S149, 0T149 or Connector 3S206

Material: PVC-U

| Nominal Size (mm) | Part Number | Colour Option | Dimensions (mm) | |
|-------------------|-------------|---------------|-----------------|----|
| | | | A | B |
| 61 | 4T836 ♡ | ● ○ | 46 | 43 |

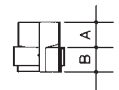

Outlet Adaptor – Square to Round

- Allows outlets to be connected to 68mm circular pipe

Material: PVC-U

| Nominal Size (mm) | Part Number | Colour Option | Dimensions (mm) | |
|-------------------|-------------|---------------|-----------------|----|
| | | | A | B |
| 61 | 4T837 ♡ | ● ○ | 43 | 30 |

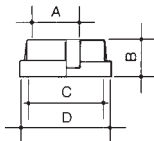

Rainwater Adaptor

- Use with Square to Round Drain Adaptor 4T836 (page 24)
- 68mm pipe to 110mm PVC-U drain
- External use only
- For use with 110mm drain socket or spigot

Material: Polypropylene

| Nominal Size (mm) | Part Number | Dimensions (mm) | | | |
|-------------------|-------------|-----------------|----|-----|-----|
| | | A | B | C | D |
| – | 4S149 | 69 | 55 | 110 | 132 |
| – | 0T149 ♡ | 69 | 55 | 110 | 132 |

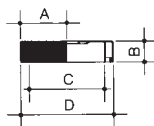

Universal Drain Adaptor

- For use with 110mm drain socket or spigot
- Accepts SquareLine downpipe without an adaptor
- External use only

Material: EPDM

| Nominal Size (mm) | Part Number | Dimensions (mm) | | | |
|-------------------|-------------|-----------------|----|-----|-----|
| | | A | B | C | D |
| – | 4S159 | 68 | 30 | 110 | 136 |

Bends, Shoe and Wall Offsets

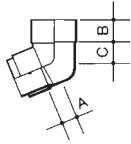

Offset Bend – Socket

- 67.5° offset
- For use as top or bottom bend

Material: PVC-U

| Nominal Size (mm) | Part Number | Colour Option | Dimensions (mm) | | |
|-------------------|-------------|---------------|-----------------|----|----|
| | | | A | B | C |
| 61 | 4T825 | ● ○ ● | 23 | 30 | 30 |



Offset Bend – Spigot

- 67.5° offset
- Minimum achievable offset 73mm
- For use as top or bottom bend

Material: PVC-U

| Nominal Size (mm) | Part Number | Colour Option | Dimensions (mm) | |
|-------------------|-------------|---------------|-----------------|----|
| | | | A | B |
| 61 | 4T826 | ● ○ ● | 23 | 57 |

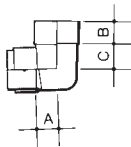

Pipe Bend – 87.5°

Material: PVC-U

| Nominal Size (mm) | Part Number | Colour Option | Dimensions (mm) | | |
|-------------------|-------------|---------------|-----------------|----|----|
| | | | A | B | C |
| 61 | 4T862 | ● ○ ● | 32 | 30 | 39 |

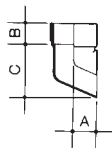

Pipe Shoe and Bracket

Material: PVC-U

| Nominal Size (mm) | Part Number | Colour Option | Dimensions (mm) | | |
|-------------------|-------------|---------------|-----------------|----|----|
| | | | A | B | C |
| 61 | 4T832 | ● ○ ● | 33 | 30 | 76 |

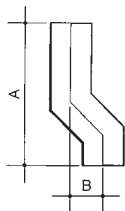

Pipe Wall Offset

- Provides 48mm offset to enable connection to drain outlet

Material: PVC-U

| Nominal Size (mm) | Part Number | Colour Option | Dimensions (mm) | |
|-------------------|-------------|---------------|-----------------|----|
| | | | A | B |
| 61 | 4T838 | ● ○ ● | 208 | 48 |

SquareLine

PVC-U Rainwater Systems

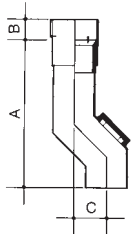

Pipe Wall Offset – with access

- Provides 48mm offset to enable connection to drain outlet
- Fitted with screwed, square access cover

Material: PVC-U

| Nominal Size (mm) | Part Number | Colour Option | Dimensions (mm) | | |
|-------------------|-------------|---------------|-----------------|----|----|
| | | | A | B | C |
| 61 | 4T858 | ● | 212 | 30 | 48 |

Branch, Access Pipe and Hopper Head

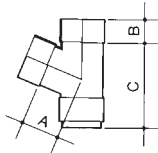

Pipe Branch – 67.5°

Material: PVC-U

| Nominal Size (mm) | Part Number | Colour Option | Dimensions (mm) | | |
|-------------------|-------------|---------------|-----------------|----|-----|
| | | | A | B | C |
| 61 | 4T835 ♡ | ● ○ ● | 56 | 30 | 122 |



Access Pipe

- Fitted with screw-fixed, square access cover

Material: PVC-U

| Nominal Size (mm) | Part Number | Colour Option | Dimensions (mm) | |
|-------------------|-------------|---------------|-----------------|----|
| | | | A | B |
| 61 | 4T855 | ● | 170 | 41 |

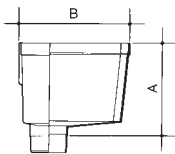

Hopper Head

- Flow capacity 2.40 l/s
- Spigot sized for 61mm square pipe

Material: PVC-U

| Nominal Size (mm) | Part Number | Colour Option | Dimensions (mm) | | |
|-------------------|-------------|---------------|-----------------|-----|-------|
| | | | A | B | Width |
| 61 | 4T830 | ● ○ ● | 138 | 178 | 255 |

Rainwater Diverter Kit

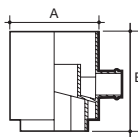

Rainwater Diverter Kit

- Provides an outlet to allow a waterbutt to be filled from a downpipe

Material: PVC-U; Connector – Polypropylene; Seal – EPDM

| Nominal Size (mm) | Part Number | Colour Option | Dimensions (mm) | |
|-------------------|-------------|---------------|-----------------|----|
| | | | A | B |
| 61 | 0T201 | ● ○ | 76 | 87 |

Spares



Gutter Seal

Material: EPDM

| Nominal Size (mm) | Part Number |
|-------------------|-------------|
| 100 | 4T864 |



Flexiclip

Material: PVC-U

| Nominal Size (mm) | Part Number | Colour Option |
|-------------------|-------------|--|
| 100 | 4T816 | <input checked="" type="radio"/> <input type="radio"/> <input type="radio"/> |



Gutter Pad – Narrow

- For 'old style' gutter joints – not flexiclip joints
- To glue in seals use waterproof contact adhesive

Material: EPDM

| Nominal Size (mm) | Part Number |
|-------------------|-------------|
| 100 | 4T860 |



Gutter Pad – Wide

- For 'old style' gutter joints – not flexiclip joints
- To glue in seals use waterproof contact adhesive

Material: EPDM

| Nominal Size (mm) | Part Number |
|-------------------|-------------|
| 100 | 4T861 |

StormLine

PVC-U Rainwater Systems

Gutter

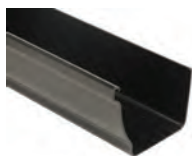

StormLine Gutter

Material: PVC-U

| Nominal Size (mm) | Part Number | Colour Option | Length (m) |
|-------------------|-------------|---------------|------------|
| 111x76x97 | 8T874 | ● ○ | 4 |

Gutter Union and Brackets

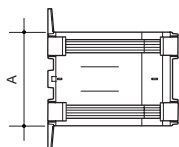

Gutter Jointing Bracket

Material: PVC-U, with EPDM seals

| Nominal Size (mm) | Part Number | Colour Option | Dimensions (mm) |
|-------------------|-------------|---------------|-----------------|
| 111x76x97 | 8T809 | ● ○ | A 100 |

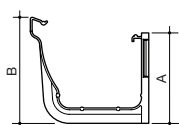

Gutter Support Bracket

- For support centres, see page 54

Material: PVC-U

| Nominal Size (mm) | Part Number | Colour Option | Dimensions (mm) | |
|-------------------|-------------|---------------|-----------------|-----|
| 111x76x97 | 8T819 | ● ○ | A | B |
| | | | 100 | 117 |

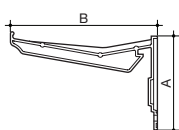

Gutter Hanging Bracket

- For unobtrusive fixing, almost invisible from ground level
- For support centres, see page 54

Material: PVC-U

| Nominal Size (mm) | Part Number | Colour Option | Dimensions (mm) | |
|-------------------|-------------|---------------|-----------------|-------|
| 111x76x97 | 8T849 | ● ○ | A | B |
| | | | 80 | 125.5 |



Gutter Bracket Spacer – 21mm Projection

- Use with Gutter Brackets 8T819 or 8T849 to provide additional 21 mm clearance

Material: PVC-U

| Nominal Size (mm) | Part Number | Colour Option | Dimensions (mm) | |
|-------------------|-------------|---------------|-----------------|----|
| – | 0T044 | ● | A | B |
| | | | 103 | 21 |

Outlets and Stopends

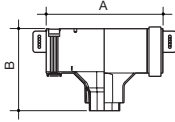

Running Outlet

- For gutter capacity, see pages 5 and 49-51
- Can be used with 68mm circular pipe and 61mm Square Pipe

Material: PVC-U, with EPDM seals

| Nominal Size (mm) | Part Number | Colour Option | | Dimensions (mm) | |
|-------------------|-------------|---------------|---|-----------------|-----|
| | | ● | ○ | A | B |
| 111x76x97 | 8T806 | ● | ○ | 220 | 175 |

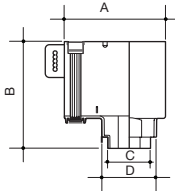

Stopend Outlet

- For gutter capacity, see pages 5 and 49-51

Material: PVC-U, with EPDM seal

| Nominal Size (mm) | Part Number | Colour Option | | Dimensions (mm) | | | |
|-------------------|-------------|---------------|---|-----------------|-------|----|----|
| | | ● | ○ | A | B | C | D |
| 111x76x97LH | 8T807 | ● | ○ | 135 | 123.5 | 58 | 71 |
| 111x76x97RH | 8T808 | ● | ○ | 135 | 123.5 | 58 | 71 |

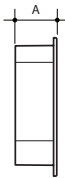

Internal Stopend

Material: PVC-U

| Nominal Size (mm) | Part Number | Colour Option | | Dimensions (mm) |
|-------------------|-------------|---------------|---|-----------------|
| | | ● | ○ | A |
| 111x76x97LH | 8T840 | ● | ○ | 33 |
| 111x76x97RH | 8T850 | ● | ○ | 33 |

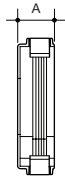

External Stopend

Material: PVC-U, with EPDM seal

| Nominal Size (mm) | Part Number | Colour Option | | Dimensions (mm) |
|-------------------|-------------|---------------|---|-----------------|
| | | ● | ○ | A |
| 111x76x97LH | 8T841 | ● | ○ | 37.5 |
| 111x76x97RH | 8T851 | ● | ○ | 37.5 |

Gutter Angles

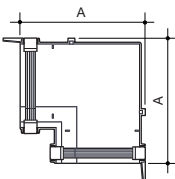

Internal 90° Angle

Material: PVC-U, with EPDM seals

| Nominal Size (mm) | Part Number | Colour Option | | Dimensions (mm) |
|-------------------|-------------|---------------|---|-----------------|
| | | ● | ○ | A |
| 111x76x97 | 8T843 | ● | ○ | 178 |

StormLine

PVC-U Rainwater Systems

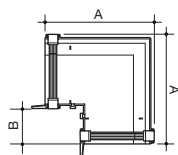

External 90° Angle

Material: PVC-U, with EPDM seals

| Nominal Size (mm) | Part Number | Colour Option | Dimensions (mm) | |
|-------------------|-------------|---------------|-----------------|------|
| | | | A | B |
| 111x76x97 | 8T853 ♡ | ● ○ | 200 | 72.5 |

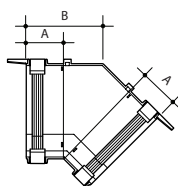

Internal 45° Angle

Material: PVC-U, with EPDM seals

| Nominal Size (mm) | Part Number | Colour Option | Dimensions (mm) | |
|-------------------|-------------|---------------|-----------------|-----|
| | | | A | B |
| 111x76x97 | 8T844 ♡ | ● ○ | 50 | 103 |

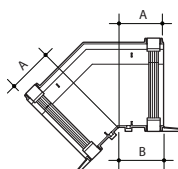
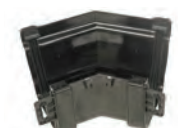

External 45° Angle

Material: PVC-U, with EPDM seals

| Nominal Size (mm) | Part Number | Colour Option | Dimensions (mm) | |
|-------------------|-------------|---------------|-----------------|----|
| | | | A | B |
| 111x76x97 | 8T854 ♡ | ● ○ | 67.5 | 67 |

Fabricated Angles

- Angles fabricated to order
- For details, contact Technical Design Department

Material: PVC-U, with EPDM seals

| Nominal Size (mm) | Part Number | Colour Option | Dimensions (mm) | |
|-------------------|-------------|---------------|-----------------|---|
| | | | A | B |
| 111x76x97 | 8T999 | ● ○ | | |

Rise and Fall Brackets and Spikes

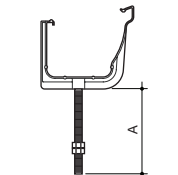

Bow and Pin for Rise and Fall Brackets

- Use with Spikes 0T985/986 or 0T988/989 (see page 31)
- Diameter of rod: 8mm

Material: Pin – Stainless steel; Bracket – PVC-U

| Nominal Size (mm) | Part Number | Colour Option | Dimensions (mm) |
|-------------------|-------------|---------------|-----------------|
| | | | A |
| 110 | 8T894 | ● ○ | 115 |

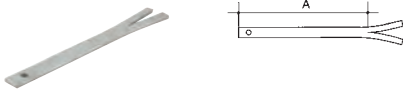

Build-in Spikes

Material: Galvanised mild steel

| Nominal Size (mm) | Part Number | Dimensions (mm) | |
|-------------------|-------------|-----------------|--------|
| | | A | Length |
| - | 0T985 | 160 | 230 |
| - | 0T986 | 260 | 330 |

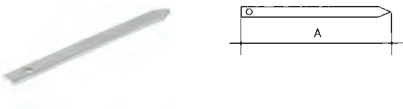

Drive-in Spikes

Material: Galvanised mild steel

| Nominal Size (mm) | Part Number | Dimensions (mm) |
|-------------------|-------------|-----------------|
| | | A |
| - | 0T988 | 230 |
| - | 0T989 | 330 |

Rafter Brackets

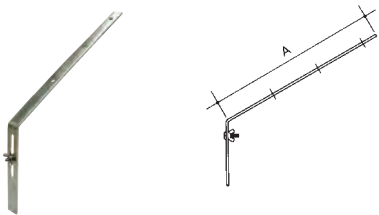

Adjustable Top Rafter Bracket

- Use with Gutter Support Bracket 8T819
- Angle of bracket: 30°

Material: BZP-plated steel

| Nominal Size (mm) | Part Number | Dimensions (mm) |
|-------------------|-------------|-----------------|
| | | A |
| - | 0T147 | 300 |

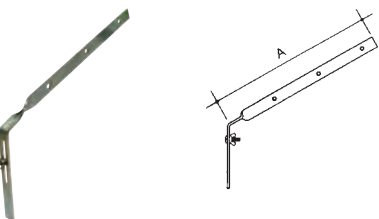

Adjustable Side Rafter Bracket

- Use with Gutter Support Bracket 8T819
- Angle of bracket: 30°

Material: BZP-plated steel

| Nominal Size (mm) | Part Number | Dimensions (mm) |
|-------------------|-------------|-----------------|
| | | A |
| - | 0T148 | 300 |

Spares



Gutter Seal

Material: EPDM

| Nominal Size (mm) | Part Number |
|-------------------|-------------|
| 111x76x97 | 8T864 |

StormLine

PVC-U Rainwater Systems



Flexiclip

Material: PVC-U

| Nominal Size (mm) | Part Number | Colour Option |
|----------------------|----------------|------------------|
| 111x76x97 | 8T816 ♡ | ● ○ |

NOTE: StormLine can directly connect to 68mm round or 61mm square downpipe. See RoundLine and SquareLine sections for product details.

DeepLine

PVC-U Rainwater Systems

Gutter

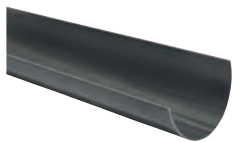

DeepLine Gutter

Material: PVC-U

| Nominal Size (mm) | Part Number | Colour Option | Length (m) |
|-------------------|-------------|---------------|------------|
| 113 | 9T974 | ● ● ○ ● ● | 4 |

Gutter Union and Brackets

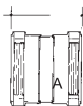

Gutter Union

- Use with Support Bracket 9T919 and Rise-and-Fall Bracket 9T994

Material: PVC-U, with EPDM seals

| Nominal Size (mm) | Part Number | Colour Option | Dimensions (mm) A |
|-------------------|-------------|---------------|-------------------|
| 113 | 9T909 | ● ● ○ ● ● | 121 |

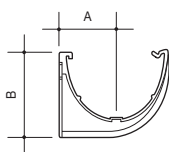

Gutter Support Bracket

- For support centres, see page 54

Material: PVC-U

| Nominal Size (mm) | Part Number | Colour Option | Dimensions (mm) | |
|-------------------|-------------|---------------|-----------------|-----|
| | | | A | B |
| 113 | 9T919 | ● ● ○ ● ● | 66 | 100 |



Gutter Bracket Spacer – 21mm Projection

- Use with Support Bracket 9T919 to provide additional 21mm clearance

Material: PVC-U

| Nominal Size (mm) | Part Number | Colour Option | Dimensions (mm) | |
|-------------------|-------------|---------------|-----------------|----|
| | | | A | B |
| – | 0T044 | ● | 103 | 21 |



Angled Bracket Spacer

- 22.5° angle
- Use with Support Bracket 9T919 when fascia board or rafter/truss ends are angled

Material: PVC-U

| Nominal Size (mm) | Part Number | Colour Option | Dimensions (mm) | |
|-------------------|-------------|---------------|-----------------|----|
| | | | A | B |
| – | 0T045 | ● | 33 | 74 |

DeepLine

PVC-U Rainwater Systems

Outlets and Stopends

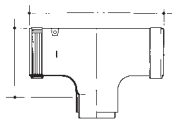

Running Outlet

- For gutter capacity, see pages 5 and 49-51
- Outlet for 68mm pipe

Material: PVC-U, with EPDM seals

| Nominal Size (mm) | Part Number | Colour Option | Dimensions (mm) | |
|-------------------|-------------|---------------|-----------------|-----|
| | | | A | B |
| 113 | 9T906 | ● ○ ● ● ● | 235 | 116 |

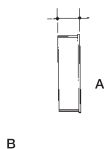
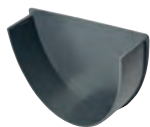

Internal Stopend

Material: PVC-U

| Nominal Size (mm) | Part Number | Colour Option | Dimensions (mm) |
|-------------------|-------------|---------------|-----------------|
| | | | A |
| 113 | 9T910 | ● ○ ● ● ● | 33 |

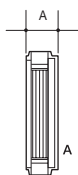

External Stopend

Material: PVC-U, with EPDM seal

| Nominal Size (mm) | Part Number | Colour Option | Dimensions (mm) |
|-------------------|-------------|---------------|-----------------|
| | | | A |
| 113 | 9T911 | ● ○ ● ● ● | 32 |

Gutter Angles

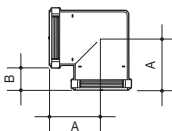

90° Angle

Material: PVC-U, with EPDM seals

| Nominal Size (mm) | Part Number | Colour Option | Dimensions (mm) | |
|-------------------|-------------|---------------|-----------------|----|
| | | | A | B |
| 113 | 9T903 | ● ○ ● ● ● | 110 | 46 |

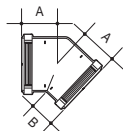

45° Angle

Material: PVC-U, with EPDM seals

| Nominal Size (mm) | Part Number | Colour Option | Dimensions (mm) | |
|-------------------|-------------|---------------|-----------------|----|
| | | | A | B |
| 113 | 9T904 | ● ○ ● ● ● | 75 | 51 |

Fabricated Angles

- Angles fabricated to order
- For details, contact Technical Design Department

Material: PVC-U, with EPDM seals

| Nominal Size (mm) | Part Number | Colour Option |
|-------------------|-------------|---------------|
| 113 | 9T999 | ● ● ○ ● |

Rise and Fall Brackets and Spikes

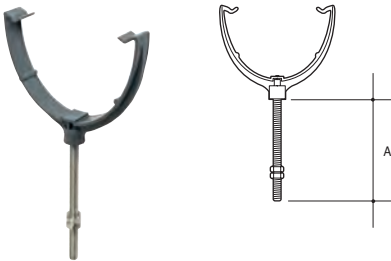

Bow and Pin for Rise and Fall Brackets

- Use with Spikes 0T985/986 or 0T988/989 (see below)
- Diameter of rod: 8mm

Material: Pin – Stainless steel; Bracket – PVC-U

| Nominal Size (mm) | Part Number | Colour Option | Dimensions (mm) A |
|-------------------|-------------|---------------|-------------------|
| 113 | 9T994 | ● ● ● | 115 |

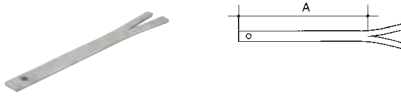

Build-in Spikes

Material: Galvanised mild steel

| Nominal Size (mm) | Part Number | Dimensions (mm) | |
|-------------------|-------------|-----------------|--------|
| | | A | Length |
| – | 0T985 | 160 | 230 |
| – | 0T986 | 260 | 330 |

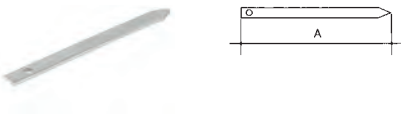

Drive-in Spikes

Material: Galvanised mild steel

| Nominal Size (mm) | Part Number | Dimensions (mm) A |
|-------------------|-------------|-------------------|
| – | 0T988 | 230 |
| – | 0T989 | 330 |

Rafter Brackets

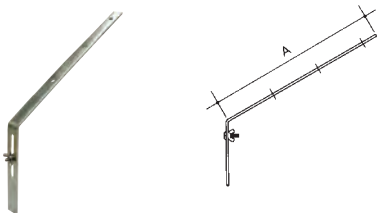

Adjustable Top Rafter Bracket

- Use with Gutter Support Bracket 9T919
- Angle of bracket: 30°

Material: BZP-plated steel

| Nominal Size (mm) | Part Number | Dimensions (mm) A |
|-------------------|-------------|-------------------|
| – | 0T147 | 300 |

DeepLine

PVC-U Rainwater Systems

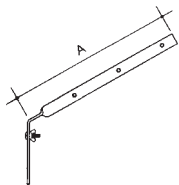

Adjustable Side Rafter Bracket

- Use with Gutter Support Bracket 9T919
- Angle of bracket: 30°

Material: BZP-plated steel

| Nominal Size (mm) | Part Number | Dimensions (mm) A |
|-------------------|-------------|-------------------|
| - | 0T148 | 300 |

Spares



Gutter Seal







Material: EPDM

| Nominal Size (mm) | Part Number |
|-------------------|-------------|
| 113 | 9T964 |



Flexiclip

Material: PVC-U

| Nominal Size (mm) | Part Number | Colour Option |
|-------------------|---|---|
| 113 | 9T916  |      |

NOTE: DeepLine connects to 68mm round downpipe. See RoundLine section for product details.

SuperLine

PVC-U Rainwater Systems

Gutter



SuperLine Gutter

Material: PVC-U

| Nominal Size (mm) | Part Number | Colour Option | Length (m) |
|-------------------|-------------|---------------|------------|
| 125 | 5T574 ♡ | ● | 4 |

Gutter Union and Brackets

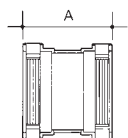

Gutter Union

- Use with Gutter Support Bracket 5T519, or with Rise-and-Fall Brackets (page 39), or with Top/Side Rafter Brackets (pages 39-40)

Material: PVC-U, with EPDM seals

| Nominal Size (mm) | Part Number | Colour Option | Dimensions (mm) A |
|-------------------|-------------|---------------|----------------------|
| 125 | 5T509 ♡ | ● | 124 |

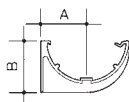

Gutter Support Bracket

- For support centres, see page 54

Material: PVC-U

| Nominal Size (mm) | Part Number | Colour Option | Dimensions (mm) | |
|-------------------|-------------|---------------|-----------------|----|
| | | | A | B |
| 125 | 5T519 ♡ | ● | 75 | 87 |



Gutter Bracket Spacer – 21mm Projection

- Use with Gutter Support Bracket 5T519 to provide additional 21mm clearance

Material: PVC-U

| Nominal Size (mm) | Part Number | Colour Option | Dimensions (mm) | |
|-------------------|-------------|---------------|-----------------|----|
| | | | A | B |
| – | 0T044 | ● | 103 | 21 |

SuperLine

PVC-U Rainwater Systems

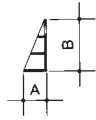

Angled Bracket Spacer

- 22.5° angle
- Use with Gutter Support Bracket 5T519 when fascia board or rafter/truss ends are angled

Material: Polypropylene

| Nominal Size (mm) | Part Number | Colour Option | Dimensions (mm) | |
|-------------------|-------------|---------------|-----------------|----|
| | | | A | B |
| – | 0T045 | ● | 33 | 74 |

Outlet and Stopends

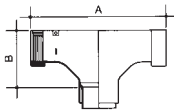

Running Outlet

- For gutter capacity, see pages 5 and 49-51
- Outlet for 68mm pipe

Material: PVC-U, with EPDM seals

| Nominal Size (mm) | Part Number | Colour Option | Dimensions (mm) | |
|-------------------|-------------|---------------|-----------------|-----|
| | | | A | B |
| 125 | 5T508 ♡ | ● | 260 | 123 |

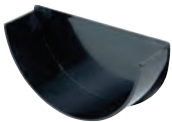

Internal Stopend

Material: PVC-U

| Nominal Size (mm) | Part Number | Colour Option | Dimensions (mm) |
|-------------------|-------------|---------------|-----------------|
| | | | A |
| 125 | 5T510 ♡ | ● | 41 |



External Stopend

Material: PVC-U, with EPDM seal

| Nominal Size (mm) | Part Number | Colour Option | Dimensions (mm) |
|-------------------|-------------|---------------|-----------------|
| | | | A |
| 125 | 5T511 ♡ | ● | 28 |

Gutter Angles

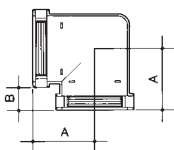

90° Angle

Material: PVC-U, with EPDM seals

| Nominal Size (mm) | Part Number | Colour Option | Dimensions (mm) | |
|-------------------|-------------|---------------|-----------------|----|
| | | | A | B |
| 125 | 5T503 ♡ | ● | 122 | 49 |

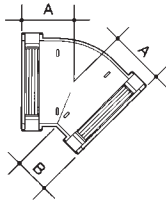

45° Angle

Material: PVC-U, with EPDM seals

| Nominal Size (mm) | Part Number | Colour Option | Dimensions (mm) | |
|-------------------|-------------|---------------|-----------------|-----|
| | | | A | B |
| 125 | 5T504 | ● | 169 | 110 |

Rise and Fall Bracket and Spikes

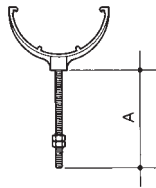

Bow and Pin for Rise and Fall Brackets

- Use with Spikes 0T985/986 or 0T988/989
- Diameter of rod: 8mm

Material: Pin – stainless steel; Bracket – PVC-U

| Nominal Size (mm) | Part Number | Colour Option | Dimensions (mm) |
|-------------------|-------------|---------------|-----------------|
| | | | A |
| 125 | 5T594 | ● | 115 |

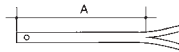

Build-in Spike

Material: Galvanised mild steel

| Nominal Size (mm) | Part Number | Dimensions (mm) | |
|-------------------|-------------|-----------------|--------|
| | | A | Length |
| – | 0T985 | 160 | 230 |
| – | 0T986 | 260 | 330 |

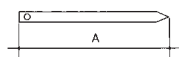

Drive-in Spike

Material: Galvanised mild steel

| Nominal Size (mm) | Part Number | Dimensions (mm) |
|-------------------|-------------|-----------------|
| | | A |
| – | 0T988 | 230 |
| – | 0T989 | 330 |

Rafter Brackets

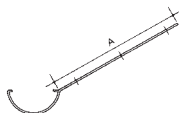

Top Rafter Bracket

- Angle of bracket: 30°

Material: PVC-coated steel

| Nominal Size (mm) | Part Number | Colour Option | Dimensions (mm) |
|-------------------|-------------|---------------|-----------------|
| | | | A |
| 125 | 5T595 | ● | 300 |

SuperLine

PVC-U Rainwater Systems

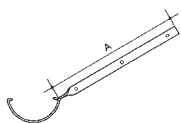

Side Rafter Bracket

- Angle of bracket: 30°

Material: PVC-coated steel

| Nominal Size (mm) | Part Number | Colour Option | Dimensions (mm) A |
|-------------------|-------------|---------------|-------------------|
| 125 | 5T596 | ● | 300 |

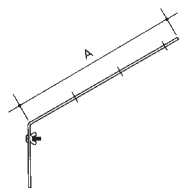

Adjustable Top Rafter Bracket

- Use with Gutter Support Bracket 5T519
- Angle of bracket: 30°

Material: BZP-plated steel

| Nominal Size (mm) | Part Number | Dimensions (mm) A |
|-------------------|-------------|-------------------|
| – | 0T147 | 300 |

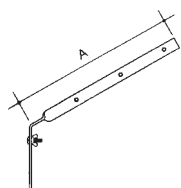

Adjustable Side Rafter Bracket

- Use with Gutter Support Bracket 5T519
- Angle of bracket: 30°

Material: BZP-plated steel

| Nominal Size (mm) | Part Number | Dimensions (mm) A |
|-------------------|-------------|-------------------|
| – | 0T148 | 300 |

Spares



Gutter Seal

Material: EPDM

| Nominal Size (mm) | Part Number |
|-------------------|-------------|
| 125 | 5T564 |



Flexiclip

Material: PVC-U

| Nominal Size (mm) | Part Number | Colour Option |
|-------------------|-------------|---------------|
| 125 | 5T516 ♡ | ● |

NOTE: SuperLine directly connects to 68mm round downpipe. See RoundLine section for product details.

RoofLine

PVC-U Rainwater Systems

Gutter



RoofLine Gutter

Material: PVC-U

| Nominal Size (mm) | Part Number | Colour Option | Length (m) |
|-------------------|-------------|---------------|------------|
| 150 | 6T674 ♡ | ● ● | 4 |

Gutter Union and Brackets

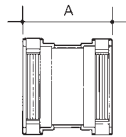

Gutter Union

- Use with Gutter Support Bracket 6T619, or with Rise-and-Fall Brackets (page 42), or with Top/Side Rafter Brackets (pages 43-44)

Material: PVC-U, with EPDM seals

| Nominal Size (mm) | Part Number | Colour Option | Dimensions (mm) A |
|-------------------|-------------|---------------|-------------------|
| 150 | 6T609 ♡ | ● ● | 125 |

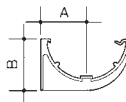

Gutter Support Bracket

- For support centres, see page 54

Material: PVC-U

| Nominal Size (mm) | Part Number | Colour Option | Dimensions (mm) A | B |
|-------------------|-------------|---------------|-------------------|-----|
| 150 | 6T619 ♡ | ● ● | 98 | 101 |



Gutter Bracket Spacer – 21mm Projection

- Use with Gutter Support Bracket 6T619 to provide additional 21mm clearance

Material: PVC-U

| Nominal Size (mm) | Part Number | Colour Option | Dimensions (mm) A | B |
|-------------------|-------------|---------------|-------------------|----|
| – | 0T044 | ● | 103 | 21 |

Outlet and Stopends

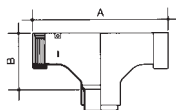

Running Outlet

- For gutter capacity, see pages 5 and 49-51
- Outlet for 110mm pipe

Material: PVC-U, with EPDM seals

| Nominal Size (mm) | Part Number | Colour Option | Dimensions (mm) A | B |
|-------------------|-------------|---------------|-------------------|-----|
| 150 | 6T606 ♡ | ● ● | 303 | 122 |

RoofLine

PVC-U Rainwater Systems

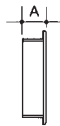

Internal Stopend

Material: PVC-U

| Nominal Size (mm) | Part Number | Colour Option | Dimensions (mm) |
|-------------------|-------------|---------------|-----------------|
| 150 | 6T610 | ● ● | A 33 |

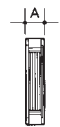

External Stopend

Material: PVC-U, with EPDM seal

| Nominal Size (mm) | Part Number | Colour Option | Dimensions (mm) |
|-------------------|-------------|---------------|-----------------|
| 150 | 6T611 | ● ● | A 29 |

Gutter Angles

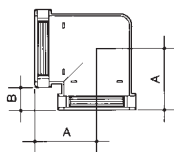

90° Angle

Material: PVC-U, with EPDM seals

| Nominal Size (mm) | Part Number | Colour Option | Dimensions (mm) |
|-------------------|-------------|---------------|-----------------|
| 150 | 6T603 | ● ● | A B 141 49 |

Fabricated Angles

- Angles fabricated to order
- For details, contact Technical Design Department

Material: PVC-U, with EPDM seals

| Nominal Size (mm) | Part Number | Colour Option |
|-------------------|-------------|---------------|
| 150 | 6T999 | ● ● |

Rise and Fall Brackets and Spikes

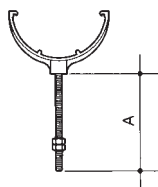

Bow and Pin for Rise and Fall Brackets

- Use with Spikes 0T985/986 or 0T988/989
- Diameter of rod: 8mm

Material: Pin – stainless steel; Bracket – PVC-U

| Nominal Size (mm) | Part Number | Colour Option | Dimensions (mm) |
|-------------------|-------------|---------------|-----------------|
| 150 | 6T694 | ● ● | A 115 |

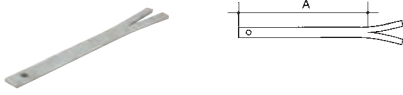

Build-in Spike

Material: Galvanised mild steel

| Nominal Size (mm) | Part Number | Dimensions (mm) | |
|-------------------|-------------|-----------------|--------|
| | | A | Length |
| - | 0T985 | 160 | 230 |
| - | 0T986 | 260 | 330 |

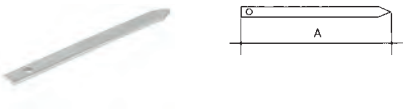

Drive-in Spike

Material: Galvanised mild steel

| Nominal Size (mm) | Part Number | Dimensions (mm) | |
|-------------------|-------------|-----------------|--|
| | | A | |
| - | 0T988 | 230 | |
| - | 0T989 | 330 | |

Rafter Brackets



Top Rafter Bracket

- Angle of bracket: 30°

Material: PVC-coated steel

| Nominal Size (mm) | Part Number | Colour Option | Dimensions (mm) | |
|-------------------|-------------|---------------|-----------------|--|
| | | | A | |
| 150 | 6T695 | ● | 300 | |



Side Rafter Bracket

- Angle of bracket: 30°

Material: PVC-coated steel

| Nominal Size (mm) | Part Number | Colour Option | Dimensions (mm) | |
|-------------------|-------------|---------------|-----------------|--|
| | | | A | |
| 150 | 6T696 | ● | 300 | |

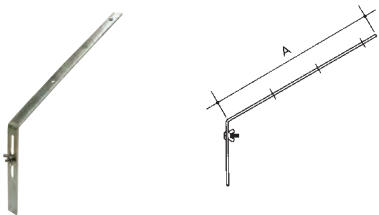

Adjustable Top Rafter Bracket

- Use with Gutter Support Bracket 6T619
- Angle of bracket: 30°

Material: BZP-plated steel

| Nominal Size (mm) | Part Number | Dimensions (mm) | |
|-------------------|-------------|-----------------|--|
| | | A | |
| - | 0T147 | 300 | |

RoofLine

PVC-U Rainwater Systems

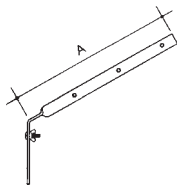

Adjustable Side Rafter Bracket

- Use with Gutter Support Bracket 6T619
- Angle of bracket: 30°

Material: BZP-plated steel

| Nominal Size (mm) | Part Number | Dimensions (mm) A |
|-------------------|-------------|-------------------|
| - | 0T148 | 300 |

Spares



Gutter Seal

Material: EPDM

| Nominal Size (mm) | Part Number |
|-------------------|-------------|
| 150 | 6T664 |



Flexiclip

Material: PVC-U

| Nominal Size (mm) | Part Number | Colour Option |
|-------------------|-------------|---------------|
| 150 | 6T616 ♡ | ● ● |

Pipe



P/E Pipe

Material: PVC-U

| Nominal Size (mm) | Part Number | Colour Option | Length (m) |
|-------------------|-------------|---------------|------------|
| 110 | 4S073 ♡ | ● ● | 3 |
| 110 | 4S074 ♡ | ● ● | 4 |

Pipe and Socket Brackets

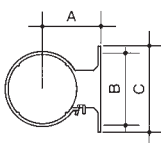

Pipe Bracket

- For pipe support centres, see page 54

Material: PVC-U

| Nominal Size (mm) | Part Number | Colour Option | Dimensions (mm) | | |
|-------------------|-------------|---------------|-----------------|-----|-----|
| | | | A | B | C |
| 110 | 4S082 ♡ | ● ● | 94 | 120 | 140 |

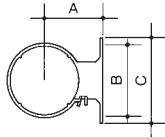

Socket Bracket

- Position in the recessed area adjacent to the sealing-ring housing
- For pipe support centres, see page 54

Material: PVC-U

| Nominal Size (mm) | Part Number | Colour Option | Dimensions (mm) | | |
|-------------------|-------------|---------------|-----------------|-----|-----|
| | | | A | B | C |
| 110 | 4S083 | ● ● | 94 | 120 | 140 |

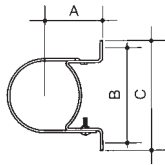

Pipe or Socket Bracket

- Multi-functional bracket that will support pipes or sockets
- When used as a socket bracket, position in the recessed area adjacent to the sealing-ring housing
- For pipe support centres, see page 54

Material: BZP-Plated steel

| Nominal Size (mm) | Part Number | Dimensions (mm) | | |
|-------------------|-------------|-----------------|-----|-----|
| | | A | B | C |
| 110 | 4S084 | 94 | 162 | 180 |

Sockets

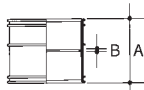

D/SW Double Socket

- Has a solvent-weld socket at each end

Material: PVC-U

| Nominal Size (mm) | Part Number | Colour Option | Dimensions (mm) | |
|-------------------|-------------|---------------|-----------------|---|
| | | | A | B |
| 110 | 4S104 | ● ● | 98 | 2 |

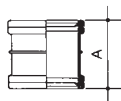

D/S Double Socket

- A slip coupler for repair work
- Has ring-seal sockets

Material: PVC-U

| Nominal Size (mm) | Part Number | Colour Option | Dimensions (mm) |
|-------------------|-------------|---------------|-----------------|
| | | | A |
| 110 | 4S105 | ● ● | 115 |

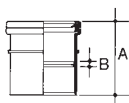

S/SW Single Socket

- For creating a fixed ring-seal joint on plain-ended pipe or fittings
- Has one ring-seal socket and one solvent-weld socket

Material: PVC-U

| Nominal Size (mm) | Part Number | Colour Option | Dimensions (mm) | |
|-------------------|-------------|---------------|-----------------|---|
| | | | A | B |
| 110 | 4S124 | ● ● | 115 | 2 |

RoofLine

PVC-U Rainwater Systems

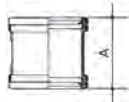

D/S Double Sockets

- Push-fit ring-seal socket at each end

Material: PVC-U, with Rubber seals

| Nominal Size (mm) | Part Number | Colour Option | Dimensions (mm) | |
|-------------------|-------------|---------------|-----------------|--|
| | | | A | |
| 110 | 4S205 ♡ | ● ● | 115 | |

Connectors and Reducer

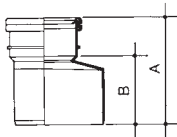

S/S Reducer

- Enables 110mm plain-ended pipe to be connected to a 160mm socket
- Has one plain end and one ring-seal or push-fit socket

Material: PVC-U

| Nominal Size (mm) | Part Number | Colour Option | Dimensions (mm) | |
|-------------------|-------------|---------------|-----------------|----|
| | | | A | B |
| 160x110 | 6S099 ♡ | ● | 127 | 70 |

Offset Bends

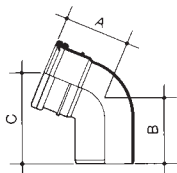

SW/S Offset Bend

- 67.5° offset
- Has one solvent-weld socket and one plain end

Material: PVC-U

| Nominal Size (mm) | Part Number | Colour Option | Dimensions (mm) | | |
|-------------------|-------------|---------------|-----------------|-----|-----|
| | | | A | B | C |
| 110 | 4S435 v♡ | ● ● | 99 | 105 | 143 |

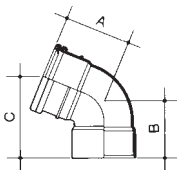

S/SW Offset Bend

- 67.5° offset
- Has one ring-seal socket and one solvent-weld socket

Material: PVC-U

| Nominal Size (mm) | Part Number | Colour Option | Dimensions (mm) | | |
|-------------------|-------------|---------------|-----------------|----|-----|
| | | | A | B | C |
| 110 | 4S440 ♡ | ● ● | 110 | 99 | 140 |

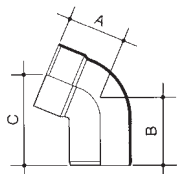

S/S Offset Bend

- 67.5° offset
- Has one plain end and one ring-seal socket

Material: PVC-U

| Nominal Size (mm) | Part Number | Colour Option | Dimensions (mm) | | |
|-------------------|-------------|---------------|-----------------|-----|-----|
| | | | A | B | C |
| 110 | 4S444 ♡ | ● ● | 110 | 105 | 147 |

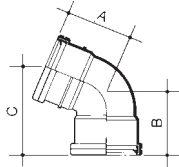

D/S Offset Bend

- 67.5° offset
- Has a ring-seal socket at each end

Material: PVC-U

| Nominal Size (mm) | Part Number | Colour Option | Dimensions (mm) | | |
|-------------------|-------------|---------------|-----------------|-----|-----|
| | | | A | B | C |
| 110 | 4S445 ▾ | ● ● | 110 | 110 | 155 |

Branches, Pipe Shoe and Hopper Head

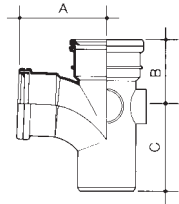

S/S Single Branch – 87.5°

- Has one plain end and two ring-seal sockets

Material: PVC-U

| Nominal Size (mm) | Part Number | Colour Option | Dimensions (mm) | | |
|-------------------|-------------|---------------|-----------------|-----|-----|
| | | | A | B | C |
| 110 | 4S190 ▾ | ● ● | 150 | 120 | 142 |

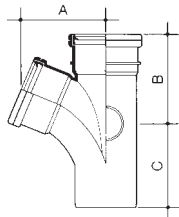

S/S Single Branch – 67.5°

- Has one plain end and two ring-seal sockets

Material: PVC-U

| Nominal Size (mm) | Part Number | Colour Option | Dimensions (mm) | | |
|-------------------|-------------|---------------|-----------------|-----|-----|
| | | | A | B | C |
| 110 | 4S200 ▾ | ● ● | 160 | 159 | 155 |

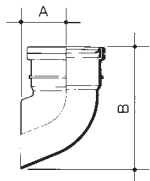

S/S Pipe Shoe

- Use with Socket Bracket 4S083
- Has one plain end and one ring-seal socket

Material: PVC-U

| Nominal Size (mm) | Part Number | Colour Option | Dimensions (mm) | |
|-------------------|-------------|---------------|-----------------|-----|
| | | | A | B |
| 110 | 4S288 ▾ | ● ● | 65 | 243 |

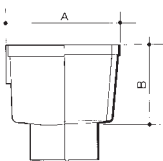

Hopper Head

- Flow capacity 6.47 l/s
- Spigot sized for 110mm socket

Material: PVC-U

| Nominal Size (mm) | Part Number | Colour Option | Dimensions (mm) | | |
|-------------------|-------------|---------------|-----------------|-----|-------|
| | | | A | B | Width |
| 110 | 4S326 ▾ | ● ● | 132 | 183 | 255 |

Roof Outlets

PVC-U Rainwater Systems

Roof Outlets

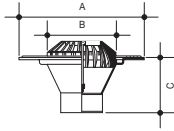

SW/S Domed Roof Outlet

- Outlet capacity (outlet at centre of roof):
82mm outlet 2.97 l/s; 143m² max. roof area
110mm outlet 4.35 l/s; 209m² max. roof area
- Fitted with:
82mm outlet solvent-weld socket
110mm outlet solvent-weld socket

Material: PVC-U

| Nominal Size (mm) | Part Number | Colour Option | Dimensions (mm) | | |
|-------------------|-------------|---------------|-----------------|-----|-----|
| | | | A | B | C |
| 82 | 3S414 | ● | 270 | 130 | 124 |
| 110 | 4S414 | ● | 338 | 188 | 147 |

Pipe Shoe

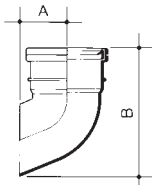

S/S Rainwater Pipe Shoe

- Use with Socket Bracket 3S083/4S083
- One plain end and one ring-seal or socket

Material: PVC-U

| Nominal Size (mm) | Part Number | Colour Option | Dimensions (mm) | |
|-------------------|-------------|---------------|-----------------|-----|
| | | | A | B |
| 82 | 3S288 | ● | 60 | 162 |
| 110 | 4S288 | ● ● | 65 | 243 |

Hopper Head

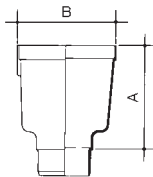

Hopper Head

- Flow capacity 3.78 l/s, 6.47 l/s
- Spigot sized for 82/110mm socket

Material: PVC-U

| Nominal Size (mm) | Part Number | Colour Option | Dimensions (mm) | | |
|-------------------|-------------|---------------|-----------------|-----|-------|
| | | | A | B | Width |
| 82 | 3S530 | ● | 260 | 190 | 255 |
| 110 | 4S326 ♡ | ● ● | 132 | 183 | 255 |

NOTE: The Roof Outlets are designed to be used with OsmaSoil downpipe and fittings. Please refer to the price list or Osma Soil and Waste Product and Installation Manual for full listings of 82mm and 110mm pipe and fittings.

Osma Rainwater

Design Procedures

Determining Gutter Flow Capacity

The capacity of a rainwater system to effectively drain a roof area depends on four factors:
 Gutter capacity Level to which the gutter is laid
 Number of outlets
 Location of outlets
 To determine the correct combination, first calculate the area to be drained – the Effective Roof Area.

Calculating Effective Roof Area: Pitched Roof

There are two methods of calculating Effective Roof Area, which allows for the effects of wind.

Method 1 (see Figure 1)

BS EN 12056: Part 3: 2000

- Measure in metres:
 - Length from eaves to ridge
 - Height of roof from eaves to ridge
 - Length of roof
- Use the formula specified in BS EN 12056: Part 3: 2000
 Effective Roof Area (in m²) = $(A + \frac{B}{2}) \times C$

3. Check this figure against the capacity of Osma systems set out in Table 1.

Worked example:

$$A = 7.0\text{m} \quad \left(\frac{7 + 3}{2}\right) \times 12 \quad (7 + 1.5) \times 12$$

$$B = 3.0\text{m} \quad \quad \quad \quad \quad \quad \quad \quad \quad \quad \quad \quad 8.5 \times 12 = 102\text{m}^2$$

$$C = 12.0\text{m} \quad \quad \quad \quad \quad \quad \quad \quad \quad \quad \quad \quad \text{Effective Roof Area}$$

Conclusion: in this example, Table 1 shows that:

- ⊙ If running outlet positioned at END of run: StormLine, DeepLine and RoofLine are suitable if laid level. All systems (except RoundLine and SquareLine) are suitable laid to a fall of 1:6000
- ⊙ If outlet positioned at CENTRE of run: All systems are suitable if laid level or to a fall of 1:600.

Method 2 (see Figure 1)

Building Regulations Part H 1990

- Measure roof plan area in square metres: Length (L) x Width (W) = Area (m²)
- To find Effective Roof Area, multiply roof plan area as follows, according to angle of pitch:
 - ⊙ if 30° pitch – Area x 1.29
 - ⊙ if 45° pitch – Area x 1.5
 - ⊙ if 60° pitch – Area x 1.87

Figure 1: Pitched roof

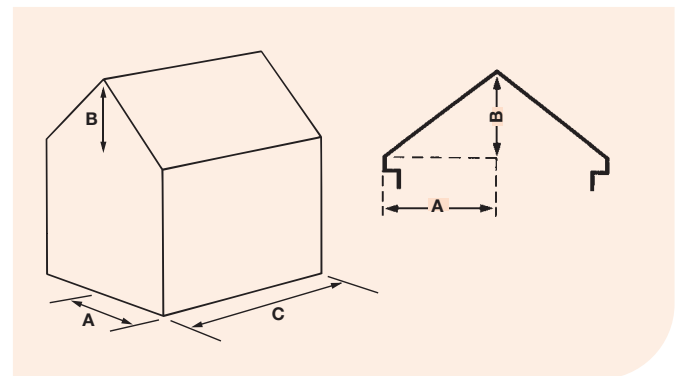

Table 1: Maximum Effective Roof Area (m²)

| System | Running outlet at END of gutter | | Running outlet at CENTRE of gutter | | Stopend outlet at END of gutter | |
|-------------|---------------------------------|---------------------------|------------------------------------|---------------------------|---------------------------------|---------------------------|
| | Gutter laid level | Gutter laid at fall 1:600 | Gutter laid level | Gutter laid at fall 1:600 | Gutter laid level | Gutter laid at fall 1:600 |
| RoundLine | 63 | 79 | 126 | 163 | 60 | 60 |
| SquareLine | 67 | 96 | 149 | 178 | 63 | 63 |
| StormLine ■ | 117 | 130 | 228 | 254 | 63 | 63 |
| StormLine ● | 115 | 125 | 221 | 239 | 61 | 61 |
| DeepLine | 114 | 145 | 228 | 299 | – | – |
| SuperLine | 101 | 121 | 207 | 250 | – | – |
| RoofLine | 119 | 164 | 245 | 317 | – | – |

NOTE: The roof areas capable of being drained are calculated in accordance with BS EN 12056: Part 3: 2000, to which reference should be made before varying design considerations.

Oasma Rainwater

Design Procedures

Determining Gutter Flow Capacity

Calculating Effective Roof Area: Wall Abutting Roof

Walls above abutting roofs will drain on to the roof below. For a single wall the effective catchment area is taken to be half the area of the elevation.

Method (see Figure 2)

1. Measures in metres:
 - D. Length of wall above roof
 - E. Height of wall above roof
2. Use the formula: Effective Wall Area (in m²) = $\frac{D \times E}{2}$
3. Add the Effective Wall Area (if appropriate) to the Effective Roof Area to be drained.

Factors to Consider

Gutter fall

Gutters laid to a fall are more efficient than gutters laid level. A fall of 1:600 (25mm in 15m) is recommended.

The high capacity characteristics of Oasma gutter systems mean that performance is not compromised by being laid level.

However, laying the gutter to a fall will increase flow capacity and the area of roof that can be drained – particularly if the downpipe is positioned centrally, Siltng will also be prevented.

Number of outlet(s)

The more outlets along a gutter, and the shorter the distance rainwater has to travel, the more effective the system.

Example:

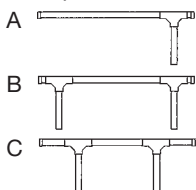

Layout B is more efficient than A, and C is more efficient than B.

Location of outlet(s)

Outlets located near gutter angles also reduce system efficiency.

Example:

Where a gutter length contains 1 or more gutter angles (greater than 10°) then multiply the Maximum Effective Roof Areas in Table 1 by a reduction factor of 0.85.

Figure 2: Wall abutting roof

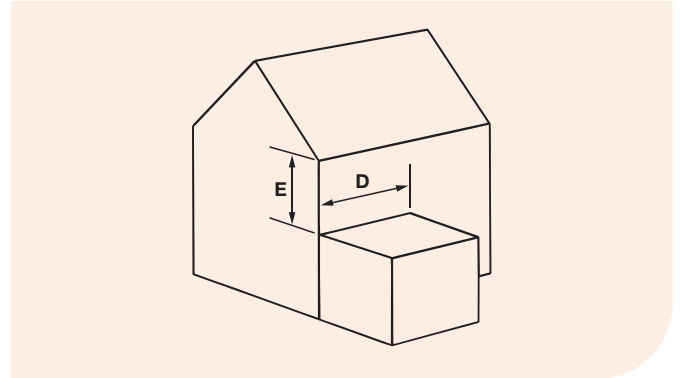

Flow Rates (litres/sec)

Our changeable climate means it is impossible to rule out flooding and overflow. Generally, it is satisfactory to design to a rainfall intensity of 75mm per hour where overflow will not cause damage within the building.

For valley and parapet gutters or where a building or its contents require additional measures of protection, a higher rainfall intensity should be used. See BS EN12056-3:2000.

Table 3 shows the maximum capacity for each system, gutter laid level or to a fall of 1:600. Established using the test method prescribed in EN12056 – 3:2000 (see next page).

To calculate flow:

- ⌚ For 75mm per hour rainfall intensity, calculate: Effective Roof Area (m²) x 0.0208 = litres per second
- ⌚ For other rainfall intensity levels, calculate as follows: Effective Roof Area (m²) x rainfall intensity (mm per hour) ÷ 3600 = litres per second

Flat Roofs

- ⦿ For roofs with a pitch less than 10°: the Effective Roof Area for the purposes of flow calculation is simply the plan area of the roof.
- ⦿ For drainage via gutters positioned at roof perimeter: Refer to Table 3 below to determine whether system capacity is sufficient for area to be drained.
- ⦿ For drainage via Osma flat roof outlets: Refer to Table 2 below.

Roof Outlets positioned in the centre of a flat roof can drain larger areas than outlets located at the edge or corner of the roof. It is good practice to have a minimum of 2 flat Roof Outlets per roof if no overflow point has been designed.



BS EN 12056: Part 3: 2000 7.3.1.

For reference to Standards see page 86.

Table 2: Roof Outlet Capacity

| Outlet | Outlet Diameter | Maximum roof area | |
|--------------|-----------------|-------------------|-------------------|
| | mm | m ² | Litres per second |
| 3S414 | 82 | 143 | 2.97 |
| 4S414 | 110 | 209 | 4.35 |

Table 3: Gutter Flow Capacity (l/s)

| System |  Running outlet at END of gutter | |  Running outlet at CENTRE of gutter | |  Stopend outlet at END of gutter | |
|--------------------|--|---------------------------|--|---------------------------|--|---------------------------|
| | Gutter laid level | Gutter laid at fall 1:600 | Gutter laid level | Gutter laid at fall 1:600 | Gutter laid level | Gutter laid at fall 1:600 |
| | RoundLine | 1.30 | 1.65 | 2.63 | 3.40 | 1.25 |
| SquareLine | 1.40 | 1.99 | 3.10 | 3.71 | 1.30 | 1.30 |
| StormLine ■ | 2.44 | 2.70 | 4.74 | 5.28 | 1.32 | 1.32 |
| StormLine ● | 2.39 | 2.60 | 4.60 | 4.98 | 1.26 | 1.26 |
| DeepLine | 2.38 | 3.01 | 5.10 | 6.21 | – | – |
| SuperLine | 2.10 | 2.52 | 4.30 | 5.19 | – | – |
| RoofLine | 2.48 | 3.41 | 4.74 | 6.59 | – | – |

Osma Rainwater

Design Procedures

Gutter Support

Gutter Location

BS EN 12056 – 3: 2000, section 7.2.1 and NE.2.1 states “Gutters designed as level or nominally level should be laid to a nominal gradient of between 1mm/m and 3mm/m where practicable. The gradient of an eaves gutter shall not be so steep that the gutter drops below the level of the roof to such an extent that water discharging from the roof will pass over the front edge of the gutter.” Also, “the gutter should be fixed centrally under the roof edge and close beneath it.”

Support Options

(see Figure 3)

Support can be provided by EITHER:

- ⦿ Gutter fittings that incorporate screwfixing positions (e.g. Running Outlet)

OR

- ⦿ Gutter Support Brackets, Hanging Brackets or Rise-and-Fall Bracket assemblies, according to the system

See Table 4 for bracketing arrangements available for each system.

Gutter Support Centres

The gutter should be supported as follows:

- ⦿ At maximum centres of 1m
- ⦿ Within 150mm of both sides of any angle
- ⦿ At the centre of gutter joints (see also Gutter Jointing page 53)

Multi-screw Brackets

For brackets where multi-screw holes are provided, we recommend that all three are used. Although the central fixing hole is sufficient (and must be used at all times), use of all three fixing holes protects against extreme weather conditions.

Use of all screw holes in the multi-screw fixings is particularly recommended on high buildings and in areas exposed to strong winds.

Rafter Brackets

Where it is not possible to screw-fix direct to fascia, Angled, Adjustable, Top and Side Rafter Brackets, and Drive-in or Build-in Spikes are available.

Angled Fascias

For support of gutters to be fixed to angled fascia, an Angled Bracket Spacer OT045 is available. This is suitable for RoundLine, SuperLine, SquareLine, StormLine and DeepLine systems.

Table 4: Alternative Bracketing Arrangements

| System | Gutter Support Bracket | Gutter Hanging Bracket | Rise-and-Fall Bow and Pin Bracket |
|------------|------------------------|------------------------|-----------------------------------|
| RoundLine | OT019 | – | OT914 |
| SquareLine | 4T819 | – | 4T894 |
| StormLine | 8T819 | 8T849 | 8T894 |
| DeepLine | 9T919 | – | 9T994 |
| SuperLine | 5T519 | – | 5T594 |
| RoofLine | 6T619 | – | 6T694 |

Figure 3: General arrangement – RoundLine

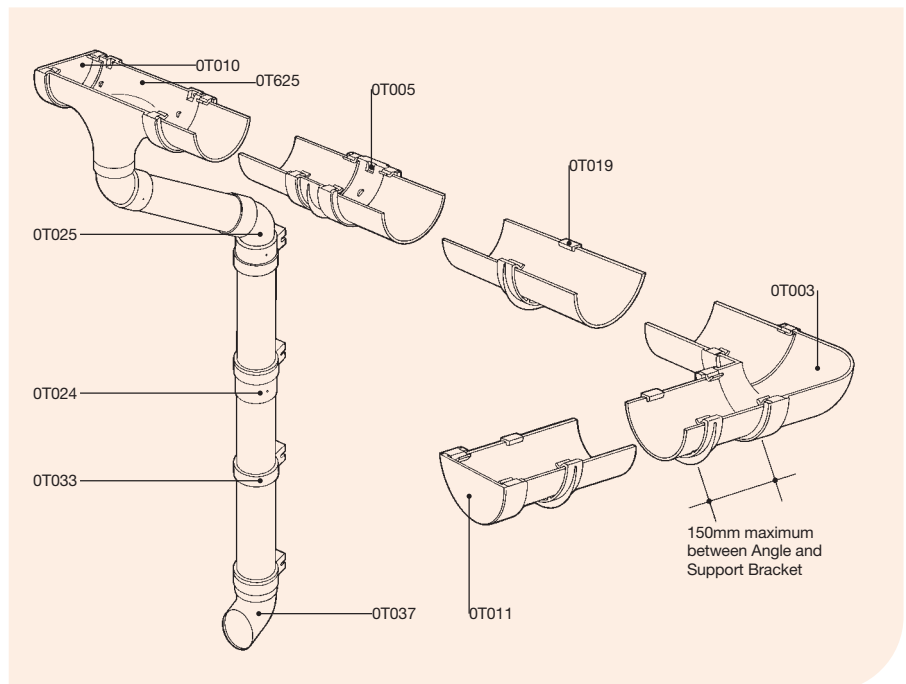

Gutter Jointing

Osma Rainwater systems are fitted with a 'Flexiclip' and seal jointing mechanism, making it easy to connect gutter to fittings. (See Figure 4). Because the clip is flexed, rather than the whole component, this ensures a positive, permanently watertight joint.

Figure 4: Flexiclip gutter joint

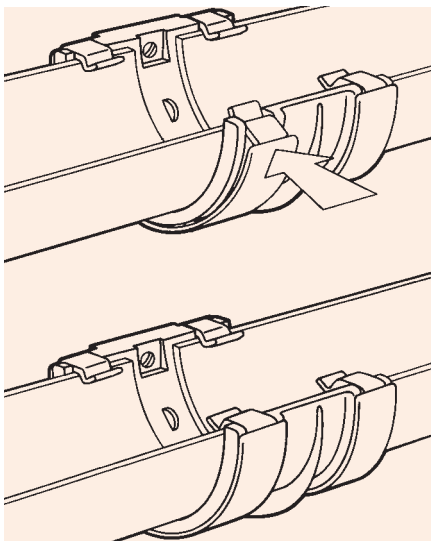

Thermal Movement

Gutter joint fittings are marked to indicate the limit for positioning gutter ends to allow for thermal expansion. These marked positions must be fully observed during assembly and installation. (See Figure 5).

Figure 5: Allowance for thermal movement

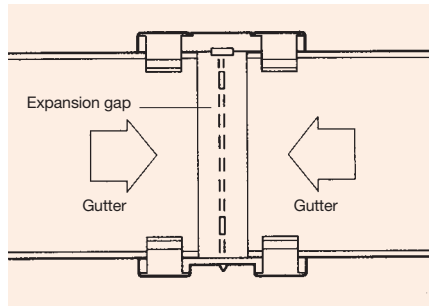

A gutter jointing bracket or gutter union with bracket should be fitted within 300mm from the end of terminal lengths of gutter.

Curved Eaves

For a gutter to fit into a curved eaves detail, it is necessary to use a number of shallow angles.

Shallow angles can be fabricated to order. Contact Wavin Technical Design Department, stating the radius and circumference of the eaves. Wavin will calculate the optimum number and angle of gutter fittings required.

Leaves

In areas where trees are close to a roof, care should be taken to ensure that gutters and pipes do not become clogged with wet leaves.

The Osma RoundLine system includes Leaf Guard OT017, which provides a simple-to-fit method to keep gutters and pipes clear of fallen leaves. Required lengths can be easily cut and simply fit inside the gutter.

Connections to Other Gutter Types

Osma RoundLine and SquareLine systems have a range of special connectors to enable joints between gutter types to be produced, (see Table 5).

These are particularly useful in refurbishment work, where it may be necessary to replace sections of old gutter but also connect to the existing gutter on adjoining buildings. (See Figures 6/7).

Table 5: Connectors

| Connection to | Connector part numbers | |
|-----------------------------------|------------------------|------------|
| | RoundLine | SquareLine |
| 4" or 4½" CI half-round | OT008 | - |
| 4" or 4½" or 5" ogee (left hand) | OT014 | - |
| 4" or 4½" or 5" ogee (right hand) | OT015 | - |
| RoundLine to SquareLine | 4T818 | 4T818 |

CI = Cast Iron

Figure 6: RoundLine connection to cast iron gutter

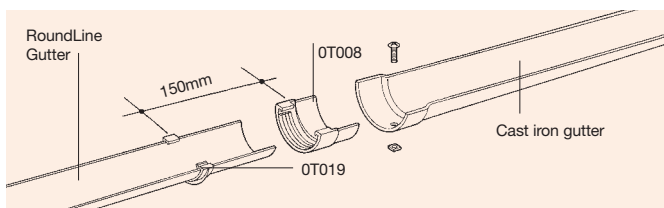
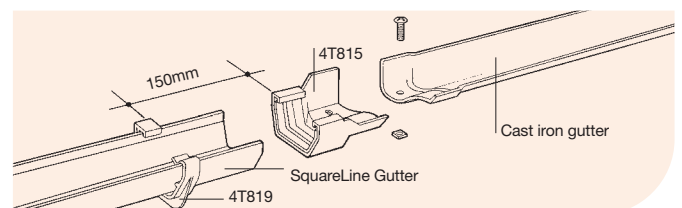

Figure 7: SquareLine connection to cast iron gutter



Osma Rainwater

Design Procedures

Pipe Support

Pipe Support Centres

The maximum support centres for pipes installed vertically and horizontally are shown in Table 6 below.

Thermal Movement

A gap of 10 -12mm must be left between the top of each length of pipe and the fitting to which it is connected to allow for thermal movement.

Offsets

To give offsets maximum support, a Pipe Bracket should be fitted directly below the lower Offset Bend.

Uneven Surfaces

For walls that have an uneven surface (for example, walls featuring 'tudorised' beams), a Pipe Bracket Spacer (OT030 - 68mm round pipe or 4T731 – square pipe) may be used to enable pipe fixings to remain in line. (See Figures 8/9).

For very uneven surfaces such as random rubble stone walls, a special Drive-in Pipe Bracket OT143 is available to use with 68mm circular pipe only.

The galvanised steel spike can be driven into the mortar joints to allow the pipe to be installed without distorting.

Table 6: Maximum Pipe Support Centres

| Pipe Size (mm) | Maximum centres (m) | |
|----------------|---------------------|------------|
| | Vertical | Horizontal |
| 61 | 2.0 | 1.0 |
| 68 | 2.0 | 1.0 |
| 82 | 2.0 | 1.0 |
| 110 | 2.0 | 1.0 |

Figure 8: Application of Pipe Bracket Spacer

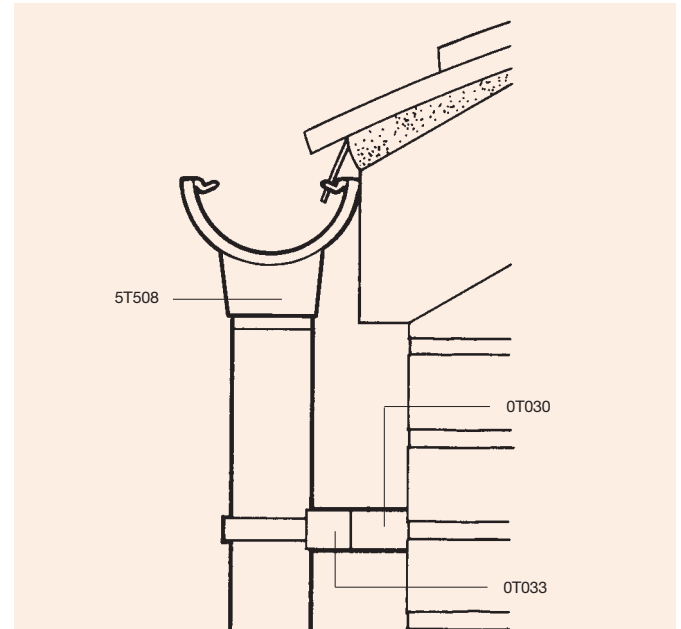
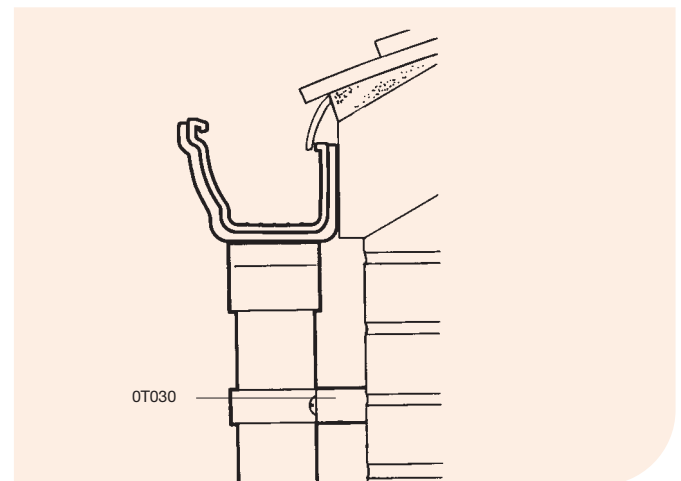

Figure 9: Use of Pipe Bracket Spacer



Osma Rainwater

Design Detailing

Typical Connections of Gutter Outlets to Osma Pipe

Each Osma rainwater gutter system offers a number of alternatives for connection of pipe to gutter system, depending upon:

- ① Depth of the fascia
- ① Whether there is a soffit
- ① What requirements the designer has of the system

All Osma systems include a Running Outlet. The following systems offer additional outlets:

- ① RoundLine: Swivelock Outlet 0T625 – (outlet fitted with integral offset bend) and Stopend Outlet 0T007
- ① SquareLine: Stopend Outlet 4T807
- ① StormLine: Stopend Outlet 8T807 – left hand; 8T808 – right hand

Table 7: Outlet Connection Components

| System | Circular pipe | | Square pipe |
|-------------------|-------------------------|-------|-------------------------|
| | 68mm | 110mm | 61mm |
| RoundLine | 0T624 0T625 0T007 | – | – |
| SquareLine | 4T806 4T807 + 4T837 | – | 4T806 4T807 |
| StormLine | 8T806 8T807 8T808 | – | 8T806 8T807 8T808 |
| DeepLine | 9T906 | – | – |
| SuperLine | 5T508 | – | – |
| RoofLine | – | 6T606 | – |

Osma Rainwater

Design Detailing

Typical Connections of Gutter Outlets

Shallow offsets

Components to achieve a shallow offset are listed in Table 8 below:

Table 8: Shallow Offset Components

| System | Components required |
|-------------------|--|
| RoundLine | 0T625 + 0T026 (90mm projection or 70mm projection by cutting back spigot of 0T026) OR 0T624 + 2 x 0T026 (90mm projection OR 70mm projection by cutting back spigot of 0T026) To be used with Pipe Bracket 0T034, fitted below lowest Offset Bend |
| SquareLine | to 68mm circular pipe 4T806/7 + 4T837 + 2 x 0T026 (90mm projection or 70mm projection by cutting back spigot 0T026) To be used with Pipe Bracket 0T034, fitted below lowest Offset Bend to 61mm square pipe 4T806/7 + 4T838 + 4T823 (minimum projection 48mm) OR 4T806/7 + 2 x 4T826 (73mm projection) To be used with Pipe Brackets 4T833 or 4T834 fitted below lowest Offset Bend |
| StormLine | to 68mm circular pipe 8T807/8 + 2 x 0T026 (90mm projection or 70mm projection by cutting back spigot of 0T026) OR 8T806 + 2 x 0T026 (90mm projection or 70mm projection by cutting back spigot of 0T026) To be used with Pipe Bracket 0T034, fitted below lowest Offset Bend to 61mm square pipe 8T806/7/8 + 4T838 + 4T823 (minimum projection 48mm) OR 8T806/7/8 + 2 x 0T026 (90mm projection or 70mm projection by cutting back spigot of 4T826) To be used with Pipe Brackets 4T833 or 4T834 fitted below lowest Offset Bend |
| DeepLine | to 68mm circular pipe 9T906 + 2 x 0T026 (90mm projection OR 70mm projection by cutting back spigot of 0T026) To be used with Pipe Bracket 0T034, fitted below lowest Offset Bend |
| SuperLine | to 68mm circular pipe 5T508 + 2 x 0T026 (90mm projection OR 70mm projection by cutting back spigot of 0T026) To be used with Pipe Bracket 0T034, fitted below lowest Offset Bend |
| RoofLine | to 110mm circular pipe 6T606 + 2 x 4S444 (minimum projection 155mm) To be used with Socket Bracket 4S083, fitted to lowest Offset Bend |

Figure 10: RoundLine shallow offset

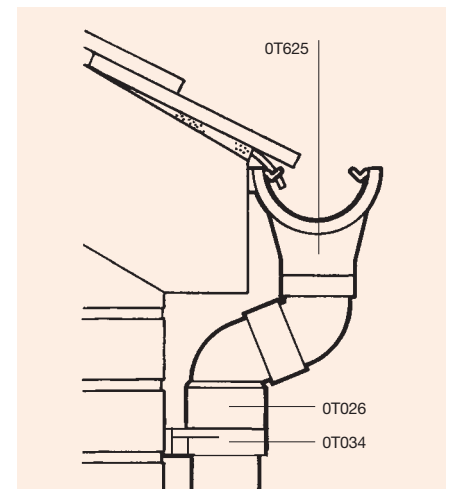

Figure 11: SquareLine shallow offset

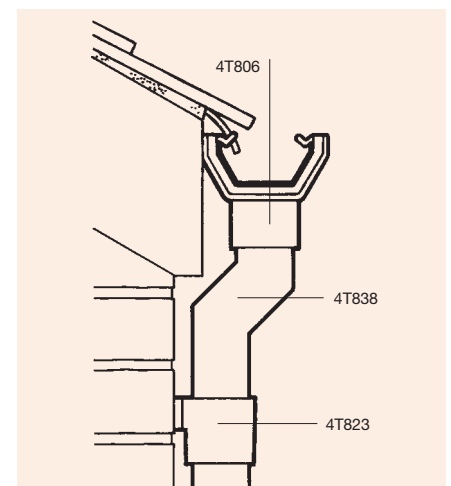
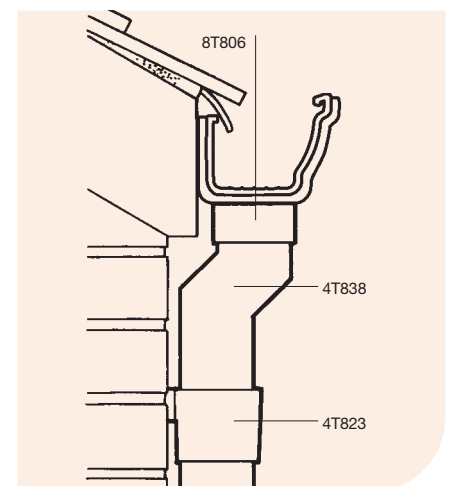

Figure 12: StormLine shallow offset



Typical Connections of Gutter Outlets

Deep offsets

Components to achieve a deep offset are listed in Table 9 below:

Table 9: Deep Offset Components

| System | Components required |
|-------------------|--|
| RoundLine | OT625 + OT025 OR OT624 + 2 x OT025 OR OT624 + OT027 + OT025 To be used with Pipe Bracket OT034, fitted below lowest Offset Bend with offcut of pipe, length to suit |
| SquareLine | to 68mm circular pipe 4T806/7 + 4T837 + OT026 + OT025 To be used with Pipe Bracket OT034, fitted below lowest Offset Bend with offcut of pipe, length to suit to 61mm square pipe for downpipe close to wall 4T806/7 + 2 x 4T825 To be used with Pipe Bracket 4T834 fitted below lowest Offset Bend with offcut of pipe, length to suit to 61mm square pipe for downpipe off the wall 4T806/7 + 2 x 4T825 To be used with Pipe Bracket 4T833 fitted below lowest Offset Bend with offcut of pipe, length to suit |
| StormLine | to 68mm circular pipe 8T806/7/8 + OT026 + OT025 To be used with Pipe Bracket OT034, fitted below lowest Offset Bend with offcut of pipe, length to suit to 61mm square pipe for downpipe close to wall 8T806/7/8 + 2 x 4T825 To be used with Pipe Bracket 4T834 fitted below lowest Offset Bend with offcut of pipe, length to suit to 61mm square pipe for downpipe off the wall 8T806/7/8 + 2 x 4T825 To be used with Pipe Bracket 4T833 fitted below lowest Offset Bend with offcut of pipe, length to suit |
| DeepLine | to 68mm circular pipe 9T906 + 2 x OT027 OR 9T906 + OT027 + OT025 To be used with Pipe Bracket OT034, fitted below lowest Offset Bend with offcut of pipe, length to suit |
| SuperLine | to 68mm circular pipe 5T508 + 2 x OT025 OR 5T508 + OT027 + OT025 To be used with Pipe Bracket OT034, fitted below lowest Offset Bend with offcut of pipe, length to suit |
| RoofLine | to 110mm circular pipe 6T606 + 2 x 4S445 OR 6T606 + 2 x 4S440 To be used with Socket Bracket 4S083, fitted to lowest Offset Bend with offcut of pipe, length to suit |

Figure 13: RoundLine deep offset

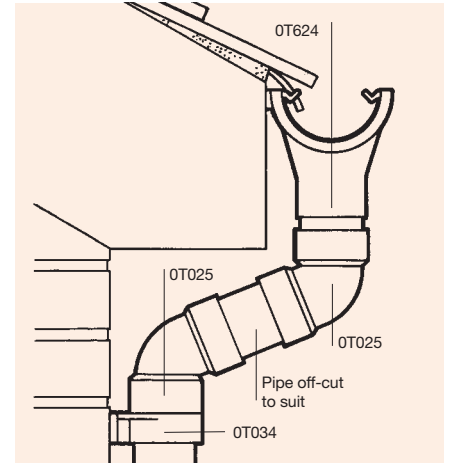

Figure 14: RoundLine deep offset and deep fascia

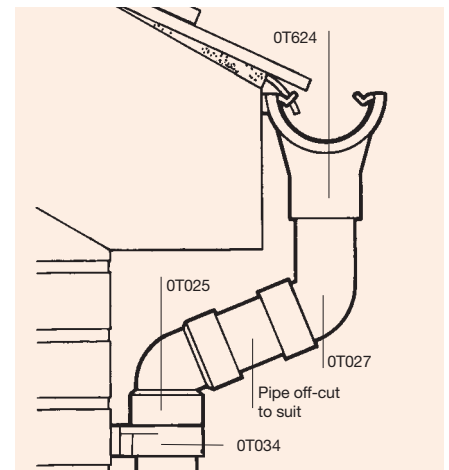
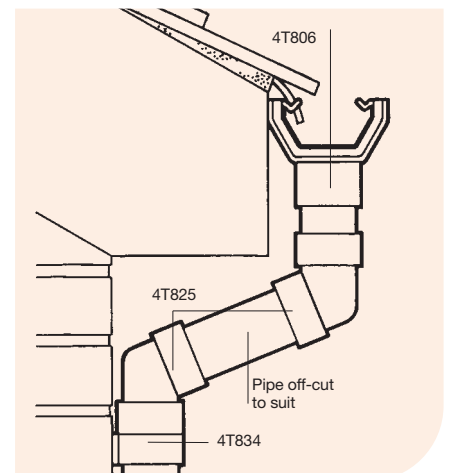

Figure 15: SquareLine deep offset – close to wall



Osma Rainwater

Design Detailing

Connections to Cast Iron Pipe

Osma Rainwater systems can be connected to the sound part of an existing circular cast iron system as follows:

RoundLine, SuperLine, DeepLine, StormLine

68mm pipe can be inserted directly into an existing 2½" cast iron socket. Mastic or other sealing compounds are not needed. For connection to a 2½" cast iron spigot, use Connector 0T092 with Pipe Connector 0T024. For connection to a 3½" cast iron spigot, use Connector 0T093 with Pipe Connector 0T024.

SquareLine, StormLine

To 2½" round cast iron socket:

Use Outlet Adaptor – Square to Round 4T837 to convert 61mm square downpipe to a 68mm circular Cast Iron Socket. Insert pipe directly in to an existing Cast Iron Socket. Mastic or other sealing compounds are not needed.

Connections to Below Ground Drainage

A number of alternative arrangements are available for terminating rainwater downpipe at ground level:

- ① Discharge over an open gully, using a Pipe Shoe for the relevant downpipe system*
- ② Indirectly, via an Osma 110mm Bottle Gully or Vertical Inlet Hopper
- ③ Directly, via a Rainwater Adaptor or Universal Drain Adaptor

NOTE: For full product details, see *Osma Drainage: Product and Installation Manual*.

Table 10 opposite sets out the component requirements for connection of downpipes to below ground drainage.

Pipe Shoes

For an open discharge*, a downpipe should be terminated with an open Pipe Shoe.

The Pipe Shoe should be situated centrally over the gully and securely fixed to the wall with the appropriate bracket (see Figure 16).

Indirect connections

Via 110mm Osma Vertical Inlet Hopper

Terminate downpipe below the back plate (see Figure 17).

Via 110mm Osma Bottle Gully

Terminate downpipe below the grating (see Figure 18).

Figure 16: Pipe Shoe over gully*
(68mm circular pipe illustrated)

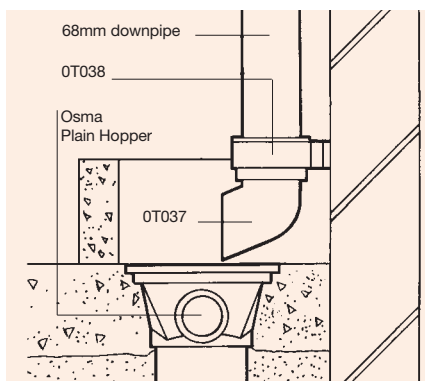

Figure 17: Connection to bottle gully
(68mm circular pipe illustrated)

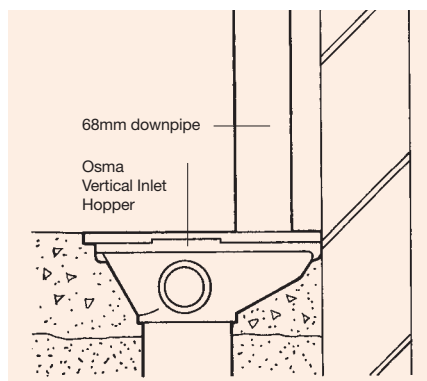

Figure 18: Connection to bottle gully

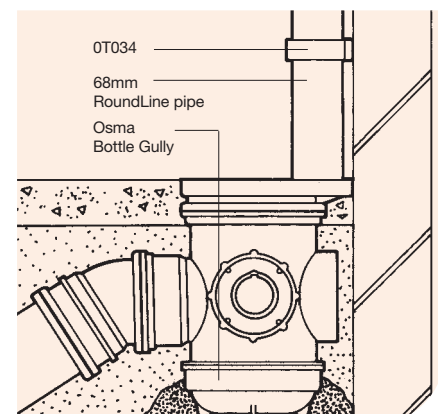

Table 10: Connections to Below Ground Drainage

| System | Circular pipe | | | | Square pipe |
|--|------------------|------------------|---|------------------------------|---------------------------------------|
| | 55mm | 68mm | 82mm | 110mm | 61mm |
| Discharge over open gully* Pipe Shoe Over Plain Hopper/Bottle Gully | 2T227 + 2T081 | 0T037 + 0T038 | 3S288 + 3S083 | 4S288 + 4S083 | 4T832 |
| Indirect Connection: to 110mm drainage Via Osma Bottle Gully | 4D700 4D900 | 4D700 4D900 | 4D095 + 3D161 Into Side Socket | 4D161 Into Side Socket | 4D700 4D900 |
| Via Osma Vertical Inlet Hopper | 4D508 4D504 | 4D508 4D504 | | | 4D508 4D504 |
| Direct Connection: to 110mm PVC-U drain Via Rainwater Adaptor | - | 0T149/4S149 | - | No Adaptor Required | 4T858/838 + 4T836 + 0T149/4S149 |
| Via Universal Drain Adaptor | 4S159 | 4S159 | - | - | 4T858/838 + 4S159 |
| Via Reducer | - | - | 4S095 | - | - |
| Direct Connection: to 82mm PVC-U drain Via Connector(s) | 3S094 | 3D206 | No Adaptor Required | - | 4T858/838 + 4T836 + 3D206 |

*NOTE: Rainwater pipe which discharges into a gully must terminate BELOW the gully grating but ABOVE the water seal, preferably by using a back inlet. (BS EN 12056: Part 3: 2000 7.6.9)

Roof Outlets

Osma Roof Outlets are two-piece components manufactured in PVC-U. They consist of a funnel-shaped body and a flange which is prominently ribbed to give good adhesion to asphalt and hot bitumen. (See Figure 19).

The outlets have a solvent socket tail for connection to pipe or bends:

- ⊕ Rebated funnel mouth allows a strong, thick edge to mastic asphalt finishes to prevent lifting
- ⊕ Grating strong enough to withstand normal foot traffic
- ⊕ Built-in gravel guard to prevent ingress of roof chippings
- ⊕ Beads and grooves prevent puddling and ensure complete seepage of water
- ⊕ Grate is secured to outlet body with anon-corrosive bolt (supplied)

Figure 19: Roof Outlet installation

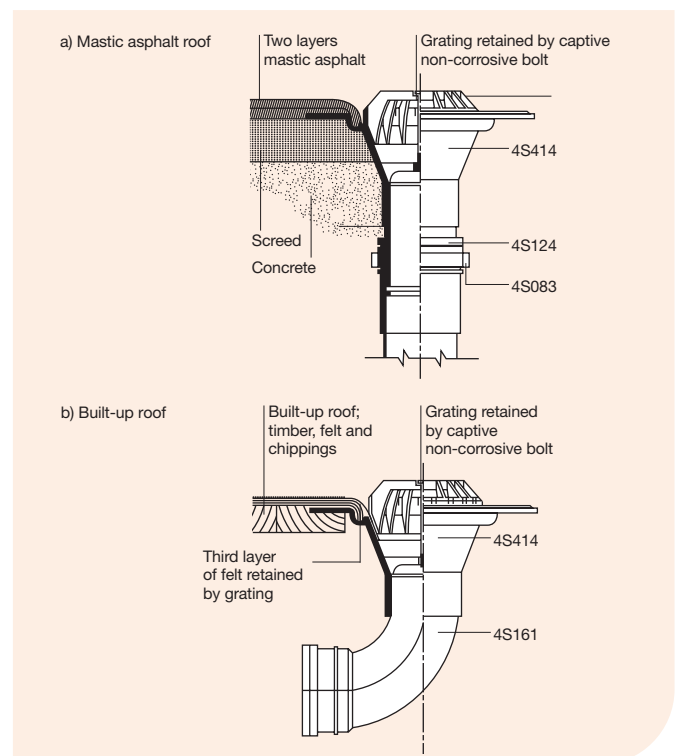

Osma Rainwater

Design Detailing

Materials: Properties and Performance

Chemical Resistance

Osma Rainwater systems components are manufactured from PVC-U or Polypropylene. They are totally unaffected by even the most heavily polluted atmosphere, or by impurities in the rainwater.

The components are self-coloured. They may, however, be painted with normal household paints if an alternative colour is required. Oil-based gloss paint is the most suitable for this purpose. For best results, slightly abrade the surface with sandpaper and clean thoroughly before painting.

Physical Attack

Osma Rainwater systems are not susceptible to insect or vermin attack.

Unlike cast iron systems, plastic has no scrap value and is therefore less likely to be targeted by vandals or thieves.

Ultra Violet Light

Osma Rainwater systems gutter, pipe and fittings are resistant to the effects of ultra violet light. Although the colour may fade slightly after a number of years exposure to strong sunlight, no integral damage occurs.

Timber Preservatives

Due to the aggressive nature of some timber preservatives, timber fascias treated with preservatives **MUST** be allowed to dry before fixing Osma Rainwater systems gutter and fittings. Refer to manufacturers' recommendations.

Osma Rainwater

Transport, Handling and Storage

Handling, Storage and Safety

Handling

Care should be taken when handling gutter and pipe. Excessive scratching or scoring harms the appearance and can also affect the joint sealing.

Take extra care when handling gutter and pipe in wintry conditions. Cold weather reduces the impact strength of plastics.

Load and unload loose gutter or pipe by hand. Avoid using skids. When loose pipes have been transported one inside the other, always remove the inner pipe first (see Figure 20).

Figure 20: Unloading of block bundles

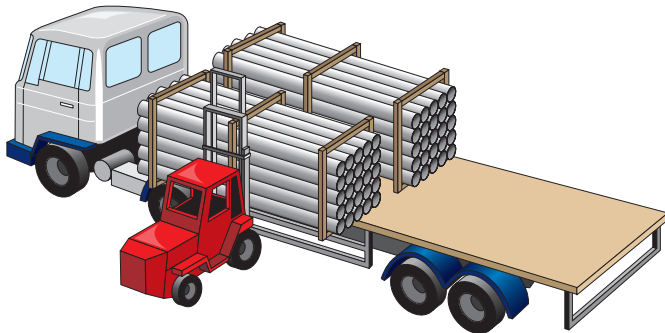

Storage

Always store gutter or pipe on a reasonably flat surface free from sharp projections.

Block Bundles

Block bundles can be stored up to 3m high without extra side supports or bearers. Block bundles will remain free-standing when cut. Take care when releasing bundles as the straps are under considerable tension and may flail when cut.

Loose Gutter or Pipe

Loose gutter or pipe requires side supports at least every 2m. These supports should consist of battens at least 75mm wide.

Ideally, support loose gutter or pipe uniformly throughout its entire length. If this is not possible, place timber supports at least 75mm wide at 1m maximum centres beneath the gutter or pipe.

Fittings

Store fittings supplied in plastic bags away from direct sunlight. If this is not possible, open bags to prevent a build-up of temperature. Store silicone lubricant in a cool place away from any heat source and out of direct sunlight.

Safety

The relevant regulations detailed in the Health and Safety at Work Act 1974 must be adhered to on site. In particular ensure ladders are properly positioned and secured.

Removing Old Guttering

Remove old gutter with care (especially if cast iron) and recycle if possible. Check condition of fascia: replace as necessary or use multi-hole screw fixings.

Maintenance

Osma Rainwater systems are designed to be maintenance-free. However, in wooded or leafy areas, gutters should be periodically checked to ensure that gutter and pipe have not worked loose or become blocked.

Figure 21: Storage of loose pipe on the ground

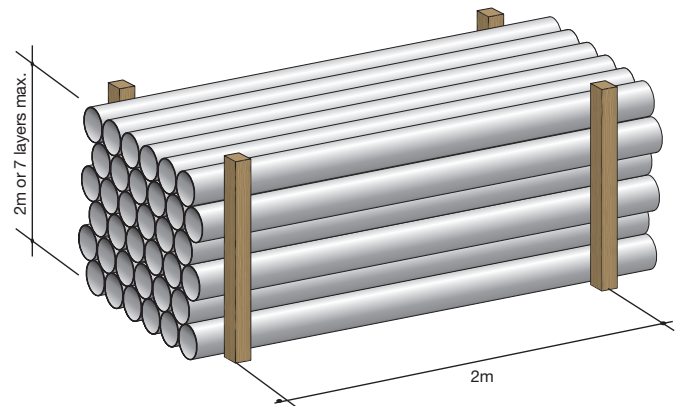
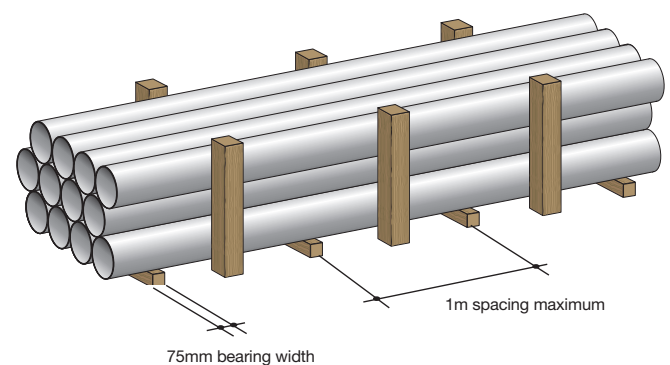

Figure 22: Storage of loose pipe on bearers



Osma Rainwater

General Techniques

Gutter Jointing

Gutter Joint Design

The Osma joint fittings are supplied complete and ready for use. The flexiclip method of gutter jointing enables easy connection of gutter to fittings. It is not necessary to remove the clip from the fitting in order to make the joint.

To make the joint, flex the clip rather than the whole component. This ensures a positive, permanently watertight joint (see Figure 23).

Figure 23: Flexiclip gutter joint

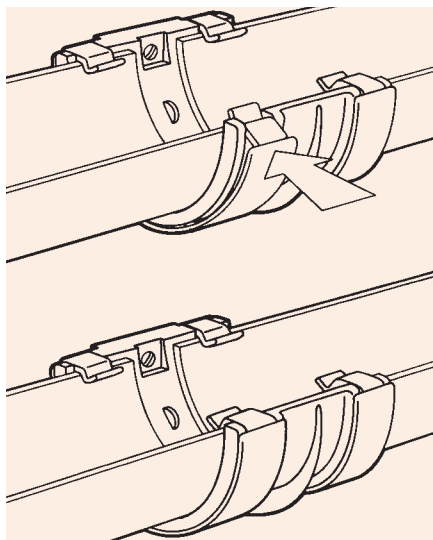

Cutting Lengths of Gutter

Lengths of gutter can be cut to fit as necessary. Use a fine-toothed hand saw and ensure that the cut is clean and square. De-burr the cut end with a scraper.

Gutter Fall

Laying Osma gutter systems to a fall of 1:600, 25mm in 15m, is recommended.

This will increase the flow capacity and increase the area of roof that can be drained, particularly if the downpipe is positioned centrally. It will also prevent silting (Refer to Flow Capacity Tables pages 49-51).

Thermal Expansion

All fittings must be firmly secured to counter the effects of accumulated thermal movement.

Allowance for thermal expansion must be made when fixing the gutter. Gutter joint fittings have a line marking the position to which the gutter should be inserted.

A gutter jointing bracket or gutter union with bracket should be fitted within 300mm from the end of terminal lengths of gutter.

Figure 24: Allowance for thermal movement

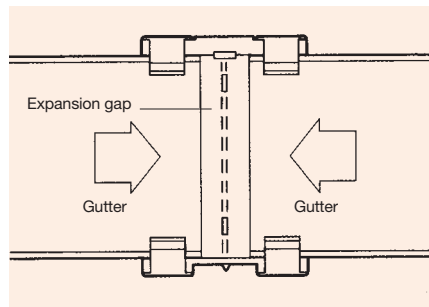

Gutter Connection

Connecting the gutter

Procedure

1. Lay the gutter to the 'gutter end line' and place it under the part of the clip nearest the fascia.
2. Pull the gutter down with the fingers whilst simultaneously pushing the clip over the gutter with the thumbs (see Figure 25).
3. Ensure edge of under-felt or membrane is dressed into gutter.

Figure 25: Connecting SquareLine Gutter

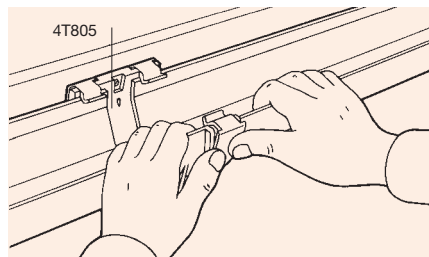

Fixing Gutter Jointing Brackets

Gutter Jointing Brackets 0T005, 4T805, and 3T305 have a single screw fixing, allowing the fitting to pivot to the required gutter fall (see Figure 26). Use 1" N°.10 rustless roundhead screws for wooden fascia, and refer to manufacturers instructions for plastic fascia.

Fixing Gutter Unions

Support Gutter Unions 0T009, 4T809, 5T509, 6T609, 8T809 and 9T909 at their centre with a Support Bracket, allowing the fitting to pivot to the required gutter fall.

Also fix Support Brackets within 1m of both sides of all gutter joints (see Figure 27).

Figure 26: Fixing Gutter Jointing Bracket (0T005)

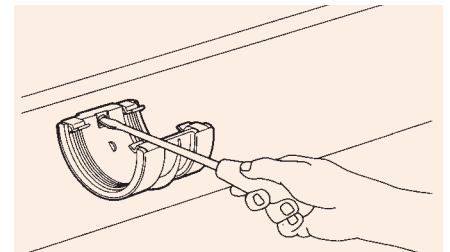
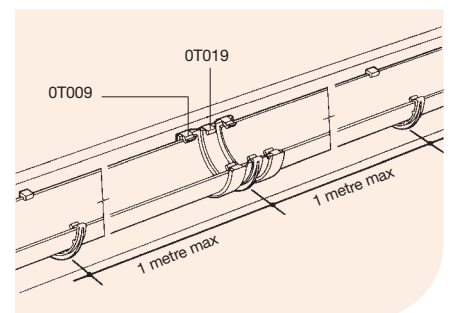

Figure 27: Installation of RoundLine Gutter Union



Gutter Connection to Other Materials

Connection to Metal Gutters

RoundLine and SquareLine only

Procedure

1. Clip PVC-U gutter into the appropriate connector (see Figures 29/30).
2. Bolt this to the metal gutter.
3. Seal the bolted joint with waterproof mastic.

Using Half-round Connector 0T008

Bolt either outside the spigot end or inside the socket end of the metal gutter.

Using Ogee Connector 0T014

(left hand), or 0T015 (right hand) Bolt inside or outside the metal gutter depending on its size:

- ⦿ 4" ogee gutter: fit Connector to the outside of both socket and spigot
- ⦿ 4½" ogee gutter: fit Connector inside the socket and outside the spigot
- ⦿ 5" ogee gutter: fit Connector on the inside of both socket and spigot

Connection to PVC-U Gutter

RoundLine only

Use RoundLine true half-round Connector 0T018 to connect to 100mm true half-round PVC-U gutter.

Figure 28: Connection to cast iron gutter

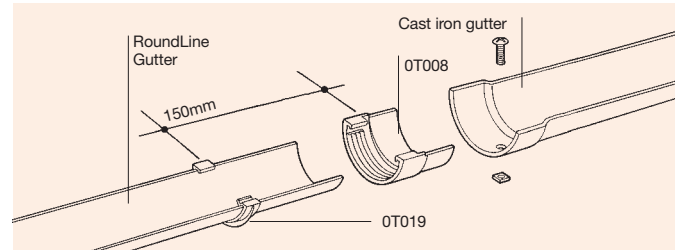
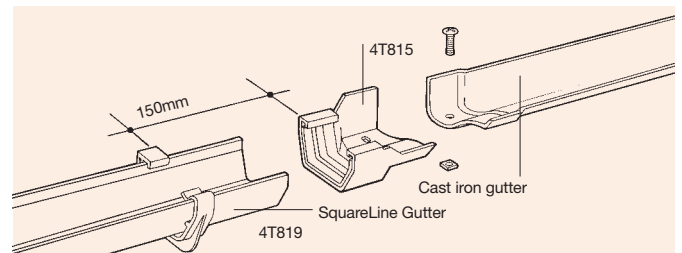

Figure 29: Connection to cast iron gutter



Gutter Support

Procedure

1. Fix the support bracket furthest from the outlet first.
2. Allow for the required fall.
3. Ensure that sufficient space is left below the roof tiles to fix the gutter.

IMPORTANT NOTE: Due to the aggressive nature of some timber preservatives, it is essential that timber fascias that have been treated with preservatives are allowed to dry before fixing PVC-U gutter fittings.

*NOTE: Rainwater pipe which discharges into a gully must terminate **BELOW** the gully grating but **ABOVE** the water seal, preferably by using a back inlet. (BS EN 12056:3:2000 7.6.9).

Figure 30: General arrangement – SquareLine system

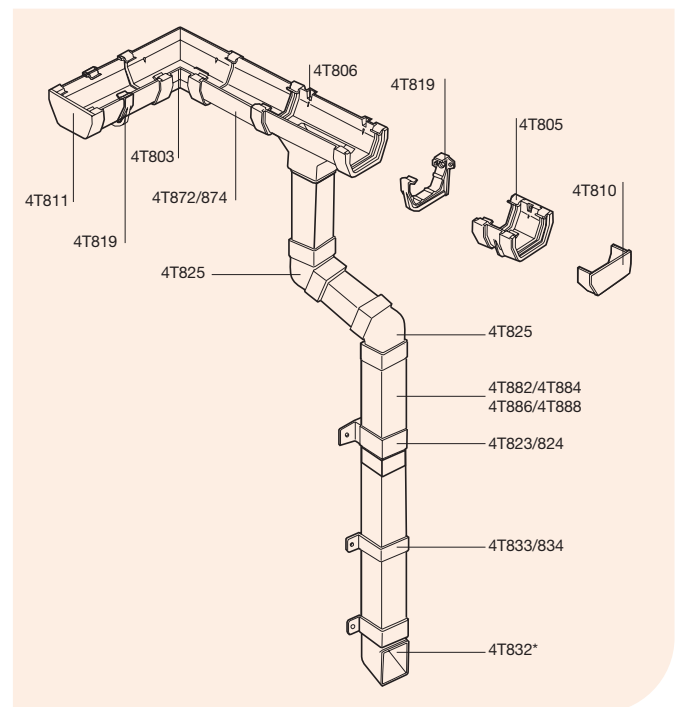

Osma Rainwater

General Techniques

Gutter Support – Installation Methods

Support Brackets

Procedure

1. String a plumb line along the base of the bracket.
2. Then securely screw fix at 1m (maximum) centres. Use 1" N°.10 rustless roundhead wood screws.
3. When installing a bracket with three fixing points, we recommend using all three, however the central fixing hole is sufficient (and must be used).

NOTE: Use multi-screw fixings on high buildings or in areas subject to high winds.

Bracket Spacers

RoundLine, SuperLine, RoofLine, DeepLine, SquareLine and StormLine

Each spacer as supplied will extend Osma Gutter Jointing Brackets, Gutter Support Brackets and Running Outlets by 21mm. Two Gutter Bracket Spacers stacked together will give an overall spacing of 40mm. Individual spacers can be cut back to a minimum of 10mm depth. Fixing should be via N°.10 rustless roundhead wood screws of appropriate length for the number of spacers used. It is recommended that no more than two Gutter Spacers are put together in one installation.

Connecting the Bow and Spike

The threaded rod of the Bow allows easy screw connection to the Spike. The threaded connection enables the Bow to be raised or lowered to give the gutter the required fall (see Figure 33).

Support Centres

Rise and Fall Brackets should be placed to support the centre of the Gutter Union and to provide intermediate support at maximum 1m centres.

Figure 31: Gutter Bracket Spacers

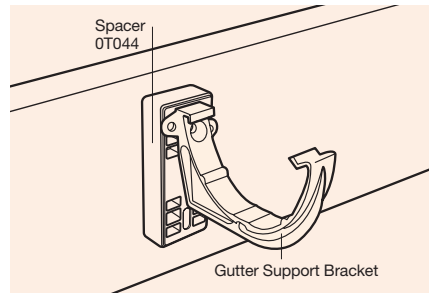

Angled Fascias

Where dwellings are designed with angled fascias, place an Angled Bracket Spacer OT045 behind Gutter Union and Support Brackets to bring them into the horizontal position (see Figure 32).

1½" N°.10 rustless roundhead wood screws are recommended for this fixing.

Snow

All Osma Rainwater systems are designed to withstand the weight of snow likely from normal falls. However, in areas subject to heavy snowfalls, the distance between support brackets should be reduced to 600mm and it is recommended that brackets are used with three fixing points, and all three fixing points are used.

BS12056: Part 3: 2000 section NB4, 7.7 and 7.2.2 gives details of precautions which should be taken to prevent the accumulation of snow on roofs. These include the use of snowboards and snowguards.

Figure 32: Application of Angled Bracket Spacer

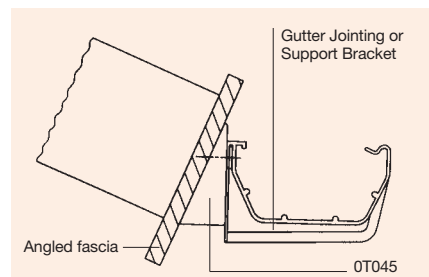

Rise-and-Fall Brackets

RoundLine, SuperLine, RoofLine, DeepLine, SquareLine and StormLine

Rise-and-Fall Brackets comprise of a Bow and Pin, fixed to the wall using either Build-in Spikes or Drive-in Spikes (see Figure 33).

Incorporate Build-in Spikes within the mortar joint below the last-but-one brick course during construction of the wall.

Drive-in Spikes are designed for installation in an existing wall. Drive the spike into the mortar joint below the last-but-one brick course.

Figure 33: Rise and Fall Bracket Assembly

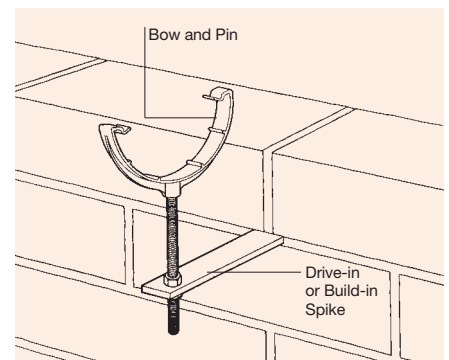
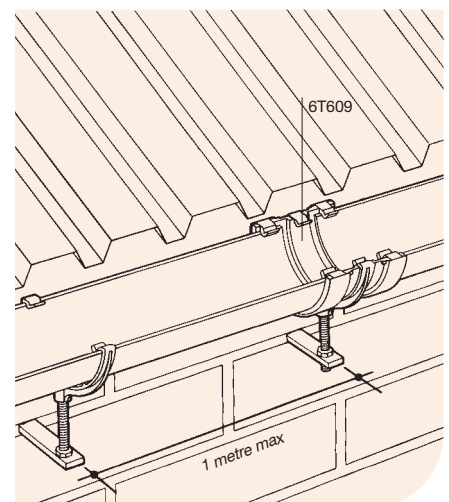

Figure 34: Installation of Rise and Fall Brackets



Rafter Brackets

RoundLine, SuperLine, RoofLine, DeepLine, SquareLine and StormLine

Designed for use when there is no fascia board, and as an alternative to Rise and- Fall Brackets. Rafter Brackets are galvanised for protection against corrosion.

Top Rafter Brackets and Side Rafter Brackets have a 30° angle and are 300mm in length. They are available in plain and adjustable format.

Figure 35: Top Rafter Bracket (OT245/745)

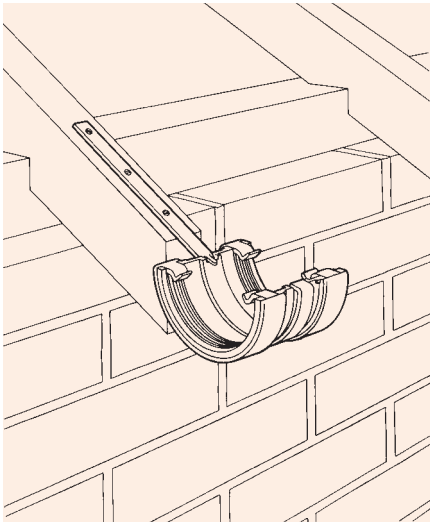

Top Rafter Brackets

Must be fixed before the roof is tiled (see Figure 35).

NOTE: If a fall is required, use the Adjustable Top and Side Rafter Brackets.

Adjustable Top and Side Rafter Brackets OT147 and OT148

RoundLine, SuperLine, RoofLine, DeepLine, SquareLine and StormLine

Adjustable Brackets have a slotted hole in the front face. This is fitted with a rust-proofed wing nut and bolt for connection to a Gutter Support Bracket (see Figures 37/38). To achieve a fall, release the wing nut and adjust the bracket up or down as necessary.

Side Rafter Brackets

Maybe fixed after roof has been tiled. They are particularly useful when replacing the gutter on an existing building. To achieve a fall, alter the position of the Brackets on the side of the rafters (see Figure 38).

Figure 36: Adjustable Top Rafter Bracket (OT147)

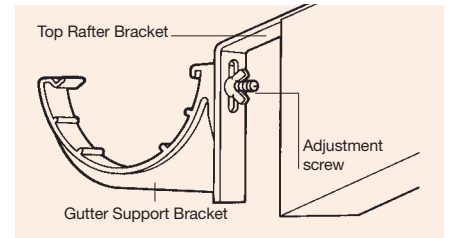

Figure 37: Adjustable Top Rafter Bracket (with SquareLine Union and Support Bracket)

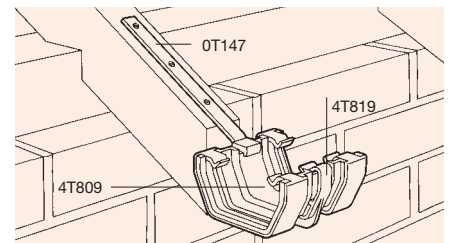
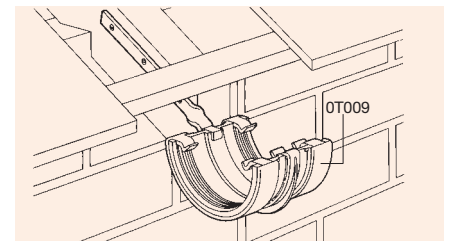

Figure 38: Side Rafter Bracket (OT246/746)



Hints and Tips

Screws

Use 1" N°.10 rustless roundhead wood screws to fix Brackets, Outlets and Angles. For correct screws to use with plastic fascias seek fascia manufacturer's advice.

Power Tools

Power tools can be used to install Osma guttering. For correct torque setting on plastic fascias, seek manufacturer's advice.

Lubricating Seals

Assembly is easier if the seal is lubricated using Osma Silicone Spray. Lubricant also improves service life and efficiency of seals.

Rainwater Diverter

This is an excellent, environmentally friendly method of collecting roof water for garden use, whilst still ensuring flow to underground drainage if the storage unit is full.

Water Test

Don't wait for a downpour do a water test of new guttering before removing the ladder.

Support Centres

Rafter Brackets should be positioned to support the centre of the Gutter Union and to provide intermediate support at (maximum) 1m centres.

NOTE: Due to the design criteria of rafters, if 1m spacing cannot be obtained, the smaller dimension should prevail, i.e. 600mm.

Osma Rainwater

General Techniques

Downpipe Cutting and Jointing

Pipe Cutting

Pipe may be cut on site using a fine-toothed hand saw.

Procedure (See Figure 39)

1. Cut pipe cleanly at right angles to its axis.
2. De-burr the cut end with a scraper. If the cut end is to be inserted into a ring-seal or push-fit joint.
3. Chamfer the spigot end: this is essential to ensure that the sealing ring is not displaced during insertion.

Figure 39: Pipe preparation

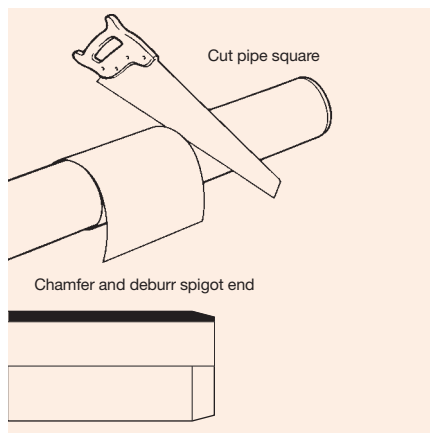

Thermal Expansion

Provision for thermal expansion must be made when installing PVC-U downpipe.

Leave a gap of 10-12mm between the top of each pipe length and the fitting to which it is connected.

Pipe Joint Design

RoundLine, SuperLine, DeepLine, StormLine

These systems utilise 68mm [2½"] circular pipe and fittings. The Pipe Connector, Branch and all Bends have an aperture socket which gives an interference fit, eliminating any need for solvent welding. This provides a neat and streamlined joint, concealing the required 10mm expansion gap between downpipe and fittings.

SquareLine and StormLine

61mm square pipe is joined with Pipe Connector 4T823/824 which has a socket at the upper end, an aperture socket at the lower end, and an integral fixing bracket. The pipe may be fixed flush to the wall or, using stand-off components 4T833/824, fixed standing off from the wall. The SquareLine system can also be used, via an adaptor, with 68mm circular pipe.

Figure 40: Pipe Connector (4T823)

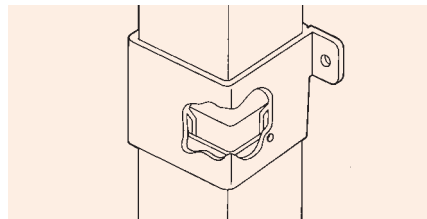

RoofLine and Roof Outlets

Utilise pipe and fittings from the Osma 82 and 110mm Soil systems. See opposite for ring-seal and solvent weld jointing.

Jointing Procedures

RoundLine, SuperLine, DeepLine, StormLine

Use a Pipe Connector 0T024 supported by a Socket Bracket 0T033/038. Ensure 10-12mm expansion gap is provided.

SquareLine and StormLine

Ensure 10-12mm expansion gap is left between the top of each pipe and the fitting to which it is connected.

RoofLine and Roof Outlets

See page 67 for ring-seal and solvent weld jointing.

Connection to Gutter Outlets RoundLine

Plain ended pipe connects directly to the sockets of the Running Outlet 0T624, the Swivelock Running Outlet 0T625 and the Stopend Outlet 0T007.

SuperLine

Plain ended pipe fits over the spigot of the Running Outlet 5T508.

DeepLine

Plain ended pipe connects directly to the socket of the Running Outlet 9T906.

RoofLine

Plain ended pipe fits over the spigot of the Running Outlet 6T606.

SquareLine

Plain ended pipe connects directly to the sockets of the Running Outlet 4T806 and the Stopend Outlet 4T807. To connect to 68mm circular pipe, use Square-to-Round Adaptor 4T837, which fits directly into the socket of the outlet (see Figure 41).

Figure 41: Assembly of offset - SquareLine

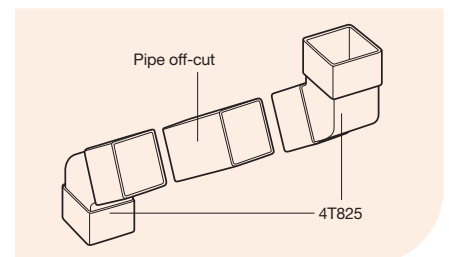

StormLine

Plain ended 68mm circular and 61mm square pipe connects directly to the sockets of the Running Outlet 8T806 and the Stopend Outlets 8T807/808.

Pipe Jointing

Jointing 82mm and 110mm pipe

Both RoofLine gutter system and Osma Roof Outlets connect to Osma 110mm PVC-U soil pipe and fittings. Osma Roof Outlets also connect to Osma 82mm PVC-U soil pipe and fittings.

Joints in lengths of 82mm and 110mm pipe may be formed by:

- ⊖ Ring-seal, push-fit jointing OR
- ⊖ Solvent weld jointing

Three sockets are available:

- ⊖ D/SW Double Socket 3S/4S104
- ⊖ D/S Double Socket 3S/4S105 (slip coupler for repair applications)
- ⊖ S/SW Single Socket 3S/4S124 (for creating a fixed ring-seal joint on plain-ended pipe or fittings)

Ring-Seal/Push-fit Jointing

Procedure

1. Ensure any pipe cut on site is also chamfered.
2. Check that the sealing ring is properly seated in its housing in the socket of the fitting.
3. Ensure all components to be joined are dry, clean and free from grit or dust. Note any deep scratches on the pipe or fitting spigot as these may prevent the sealing ring from forming a water tight seal.
4. Lubricate evenly around the pipe or fitting spigot end with Silicone Lubricant 4S391. Do NOT lubricate inside the socket. Do NOT use washing up liquid as a lubricant.
5. Correctly align the components to be joined.
6. Push the pipe or fitting spigot fully into the socket. Mark the pipe or fitting spigot at the socket face and then withdraw it by a minimum of 12mm.
7. Make a subsequent check to ensure that the expansion gap is not lost during further installation work.

Silicone Lubricant Allowance

50g tube 4S391: Sufficient for 9 joints of 110mm pipe and 16 joints of 82mm pipe.

Silicone Lubricant Spray

400ml can 4S392: Spray the lubricant onto the spigot and not the ring seal. The spigot can then be inserted into the socket. After installation ensure the pipework is thoroughly flushed through with clean water.

Solvent Weld Jointing

Procedure

1. Before using any solvent based cleaners or cement:
 - Read instructions on the can
 - Ensure there is sufficient ventilation.
2. Make sure pipe or fitting spigot and solvent weld socket are dry, clean and free from grit or dust.
3. Clean surfaces of spigot and socket with Degreasing Cleaner N°.1 4S379/380. Apply liberally using a clean non-synthetic rag or absorbent paper.
4. Apply one coat Solvent Cement N°.2 4S383/384/385. Apply an even coat to both surfaces using the applicator provided or a paint brush. Stroke the cement ALONG and not around the surfaces.
5. Immediately insert pipe or fitting spigot fully into the socket. Each solvent weld joint MUST be completed within 1½ minutes.
6. Hold for 20-30 seconds. Remove any surplus cement from the mouth of the socket.
7. The joint may be handled after 10 minutes and commissioned after 24 hours.

Degreasing Cleaner Allowance (approx.)

- ⊖ N°.1 - 125ml can 4S379: Sufficient for 16 joints of 110mm pipe
- ⊖ N°.1 - 250ml can 4S380: Sufficient for 32 joints of 110mm pipe

Solvent Cement Allowance

- ⊖ N°.2 - 125ml can 4S383: Sufficient for 5 joints of 110mm pipe
- ⊖ N°.2 - 250ml can 4S384: Sufficient for 11 joints of 110mm pipe
- ⊖ N°.2 - 500ml can 4S385: Sufficient for 22 joints of 110mm pipe

Safety

When making solvent weld joints it is essential to observe normal safety rules for handling solvent:

- ⊖ Never smoke or bring naked flames near the area of work
- ⊖ Work in a well ventilated area to avoid inhaling fumes
- ⊖ Close the solvent container after use and store in a cool area
- ⊖ Do not allow solvents or cleaners to come into contact with skin

Refer to COSHH Regulations (Control of Substances Hazardous to Health) where applicable.

Osma Rainwater

General Techniques

Pipe Support and Offsets

Pipe Support Centres

Refer to Table 11 below for the maximum support centres for pipes.

Table 11: Maximum Pipe Support Centres

| Pipe Size (mm) | Maximum centres (m) | |
|----------------|---------------------|------------|
| | Vertical | Horizontal |
| 61 | 2.0 | 1.0 |
| 68 | 2.0 | 1.0 |
| 82 | 2.0 | 1.0 |
| 110 | 2.0 | 1.0 |

RoundLine, SuperLine, DeepLine, StormLine

For 68mm Circular Pipe, the concealed Pipe or Socket Bracket 0T033, or Pipe Bracket 0T034 may be used (see Figure 42).

SquareLine and StormLine

On installations featuring 'tudorised' beams on external walls, it may be necessary to use a Pipe Bracket Spacer 4T731 (see Figure 43). This is designed for use with the Pipe Bracket, Pipe Connector and Pipe Shoe. The Pipe Bracket Spacer can be adjusted by cutting to the required depth.

Eaves without Soffit

For 68mm Circular Pipe

Keep rainwater pipe parallel to the wall by fitting a Bracket Spacer 0T031 behind the Pipe Bracket or Pipe/Socket Bracket (see Figure 44). The Bracket Spacer moves the pipe 36mm further away from the wall and puts it directly in line with the gutter outlet.

For 61mm Square Pipe

On installations where the fascia board is fitted to an external wall, or where there is a small eaves projection, use Pipe Wall Offset 4T836.

Figure 42: Pipe or Socket Bracket (0T033)

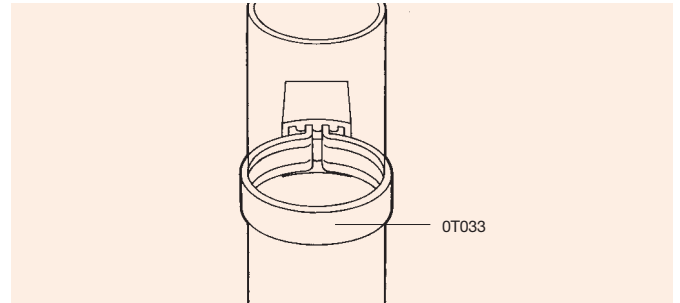

Figure 43: Use of Pipe Bracket Spacer

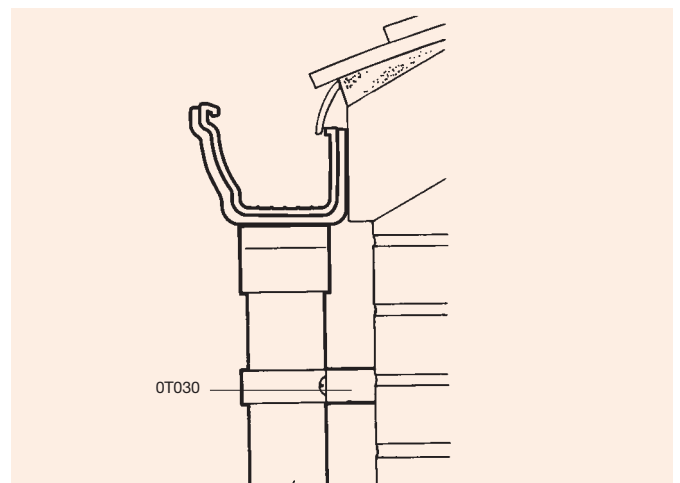
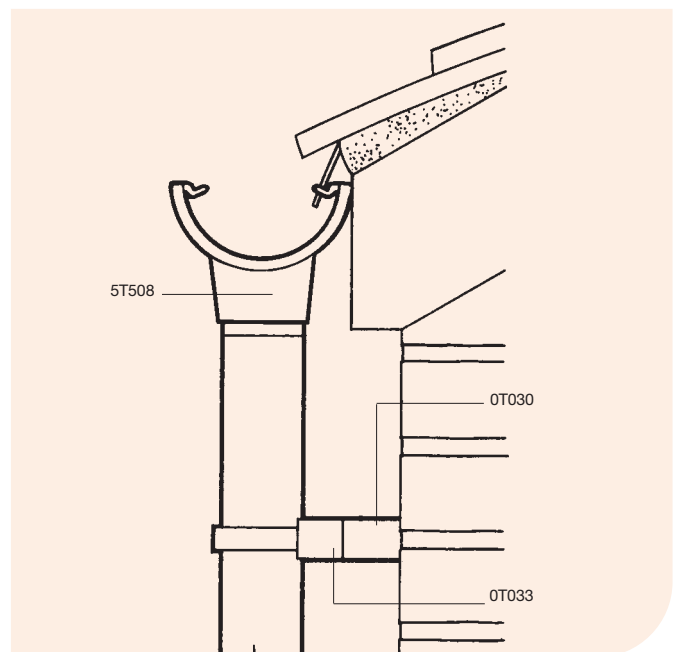

Figure 44: Application of Pipe Bracket Spacer



Pipe Support and Offsets continued

Offsets

Assemble offsets using Offset Bends. Where necessary, to provide the necessary projection, include a length of pipe offcut to suit. (see Figures 46/47/48 for typical examples).

For a complete list of components for shallow and deep offsets (by system), see pages 56-57.

Offset Support

To ensure offsets are adequately supported, fit a Pipe/Socket Bracket around the pipe directly below the lower Offset Bend.

SquareLine

When using a SquareLine Pipe Wall Offset 4T739, support is provided by a Pipe Connector and Bracket 4T824 which features an integral fixing bracket.

Pipe Wall Offset – with access 4T858 contains an integral bracket.

Figure 45: Assembly of offset - SquareLine

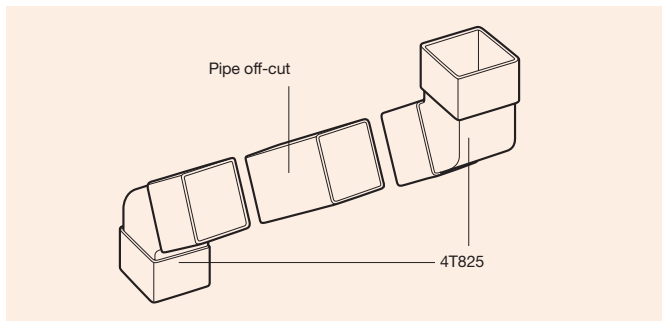

Figure 46: RoofLine shallow offset

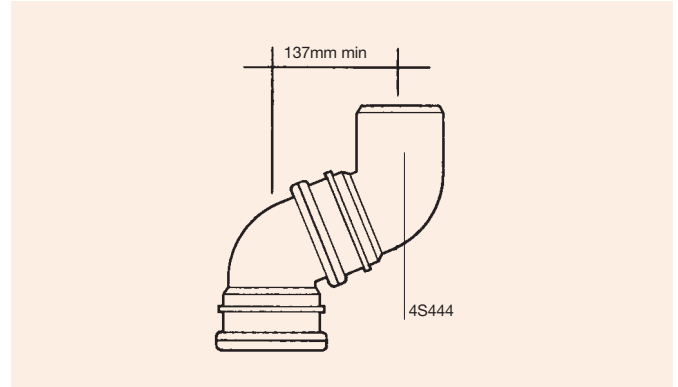
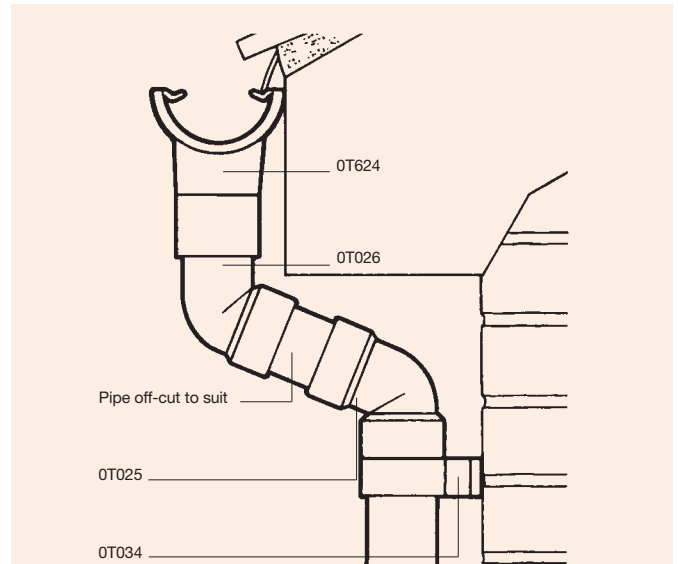

Figure 47: Offset on deep fascia



Installation of Rainwater Diverter Kit

RoundLine, SquareLine, StormLine, DeepLine and SuperLine

Procedure

1. Position waterbutt at required height next to downpipe.
2. Cut away a 30mm section of downpipe, 30mm below the top rim of the waterbutt and insert the downpipe connector.
3. Drill a 26mm hole 80mm down from the top rim of the waterbutt.
4. Fit the waterbutt connector and washer from the inside.
5. Fit the nut from the outside: tighten nut to form a seal.
6. Cut the connecting hose to the required length and fit between butt and downpipe connection.

IMPORTANT NOTE: Diverter Kit not suitable for cast iron drainpipes.



Osma Rainwater

System Connections

Connections to Below Ground Drainage

Downpipes may be terminated at ground level by using an adaptor, a pipe shoe, feeding directly into a gully or directly into a drain socket.

Details of required components, system requirements and compatibilities are shown on this and following pages.

Using Rainwater Adaptor 4S149/OT149

The Adaptor can be used with either a spigot or socket of a 110mm pipe. 68mm Circular Pipe (see Figure 48).

Procedure

1. Fit the Adaptor over the spigot or socket.
2. Fit the end of the 68mm Circular pipe into the plain socket of the Adaptor. Lubrication or solvent welding is not necessary.

SquareLine 61mm Square Pipe

(See Figures 50 and 51).

Procedure

1. Fit the Adaptor over the spigot or socket.
2. Fit Drain Adaptor 4T836 – Square to Round into the plain socket of the Adaptor.
3. Place the 61mm SquareLine pipe into the Drain Adaptor.

Pipe Wall Offset 4T838, or Pipe Wall Offset – with access 4T858 can be used to connect pipe to drain position as required.

Figure 48: Connection to 110mm PVC-U Spigot (68mm circular pipe)

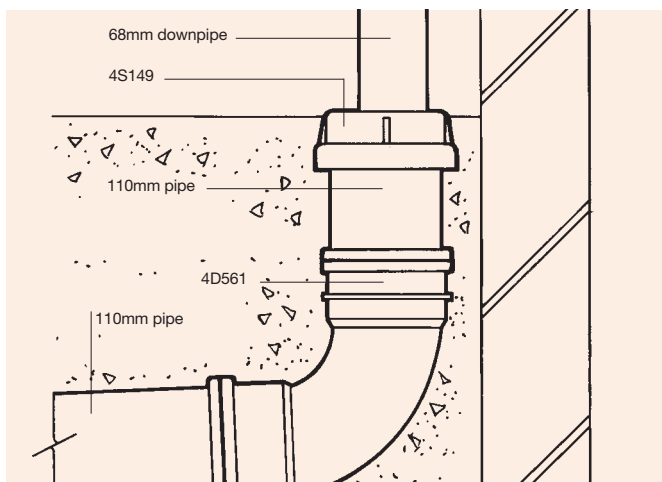

Figure 49: Connection to 110mm PVC-U Socket (61mm square pipe)

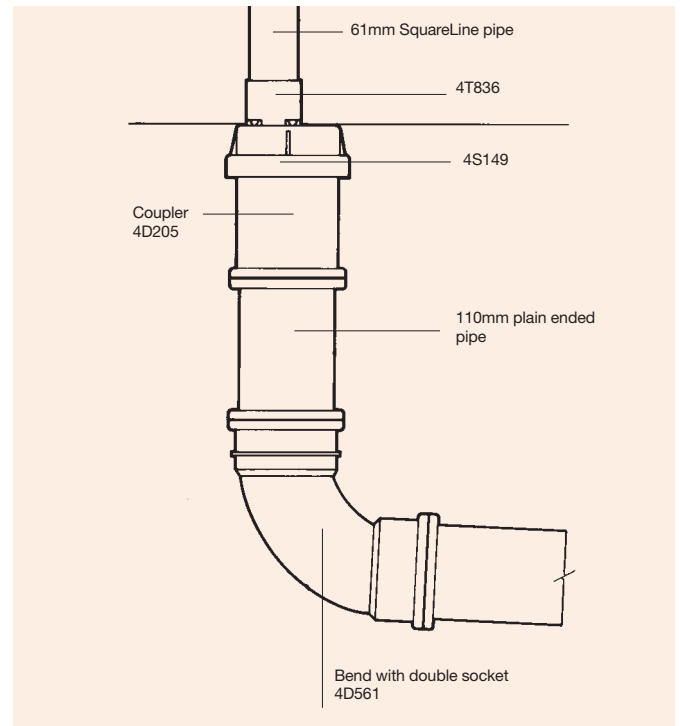
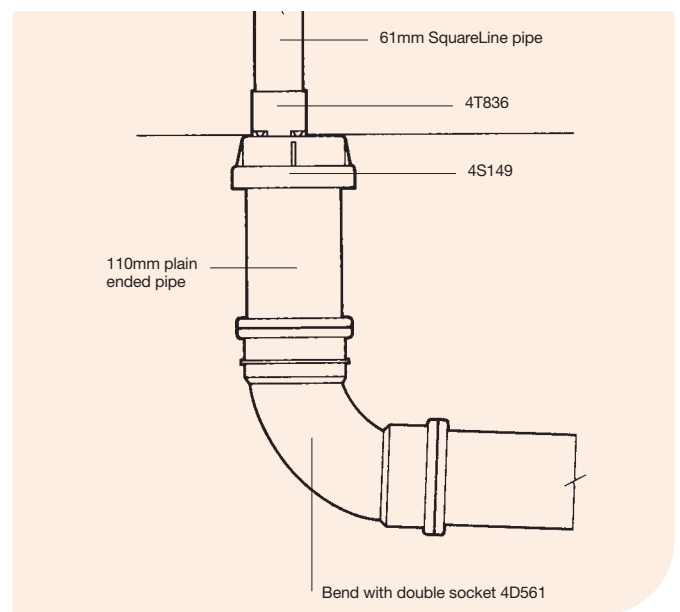

Figure 50: Connection to 110mm PVC-U Socket (61mm square pipe)



Connections to Below Ground Drainage continued

Using Universal Drain Adaptor 4S159

The Universal Drain Adaptor is suitable for connecting both circular and square section pipe, up to 70mm. It can be fitted onto a 110mm pipe spigot or socket, but is suitable for EXTERNAL applications only.

68mm Circular Pipe

(see Figure 51).

Procedure

1. Ensure the 68mm Circular pipe is free from swarf.
2. Place the pipe into the Adaptor, working the pipe through the opening, until the pipe is located in the adaptor to a suitable depth.
3. Fix a Pipe Bracket 0T034 no more than 150mm from the Adaptor.

61mm Square Pipe

(see Figure 52).

Procedure

1. Using the cutting guides located on the underside of the Adaptor, cut the Adaptor to the required size.
2. Fit the Adaptor to either a 110mm drain spigot or 110mm socket.
3. Ensure pipe is free from swarf.
4. Place the pipe into the Adaptor, working the pipe through the opening until the pipe is located in the Adaptor to a suitable depth.
5. Fix Pipe Bracket 4T833/834 no more than 150mm from the Adaptor.

Pipe Shoe

Provides open discharge* from downpipe (see Figure 53).

Procedure

1. Locate Pipe Shoe centrally over gully.
2. Fix securely to wall using Pipe Bracket.

*NOTE: Rainwater pipe which discharges into a gully must terminate BELOW the gully grating but ABOVE the water seal, preferably by using a back inlet. Where discharge onto a lower roof or paved area is unavoidable, fit a pipe shoe to divert water away from the building and reduce splashing.

Figure 51: Connection of 68mm circular rainwater pipe

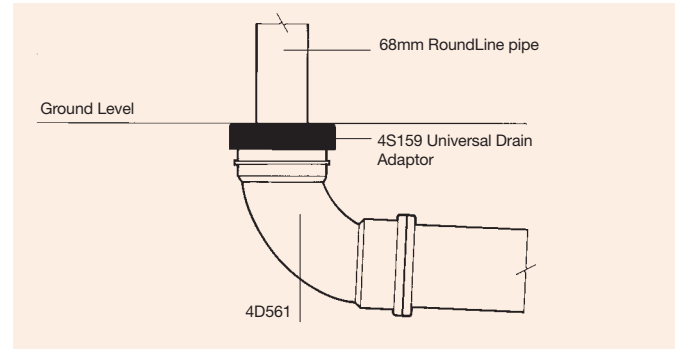

Figure 52: Connection of 61mm square rainwater pipe

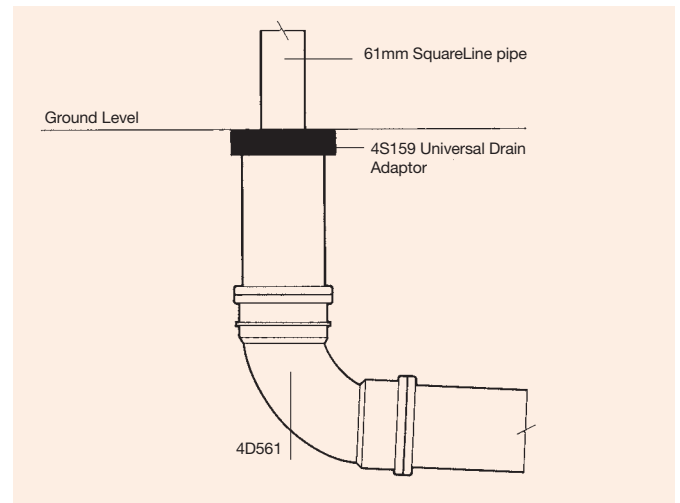
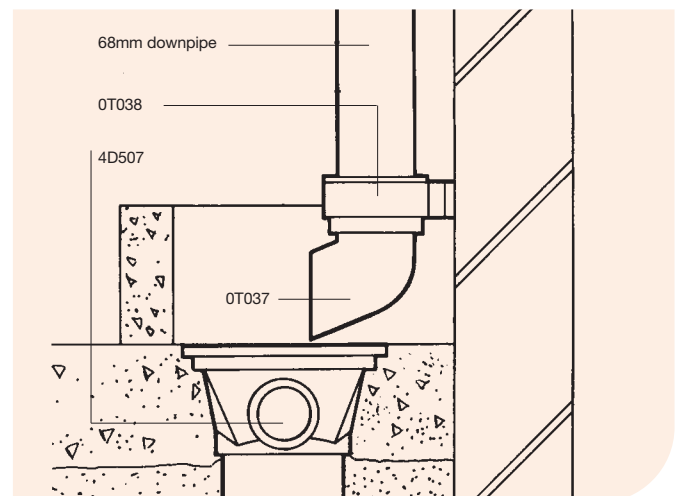

Figure 53: Pipe Shoe over Gully (68mm circular pipe illustrated)



Osma Rainwater

System Connections

Connection to Bottle Gully

The rainwater downpipe or Pipe Wall Offset can be connected to a Bottle Gully (see Figure 54).

Procedure

1. Remove a section of the Bottle Gully grating so that the downpipe sits neatly below the grating.
2. Position a pipe bracket no more than 150mm from the grating.

Connection to Vertical Inlet Hopper

The rainwater downpipe or Pipe Wall Offset can also be connected to a Vertical Inlet Hopper (see Figures 56 and 57).

Procedure

1. Cut a hole in the back plate.
2. Insert the pipe making sure discharge is below the grating.

RoofLine Connection to 110mm Drain Socket

Osma RoofLine system utilises Osma 110mm Soil pipe. This can be connected directly into a drain socket (see Figure 57).

Figure 54: Connection to Bottle Gully (68mm Circular pipe illustrated)

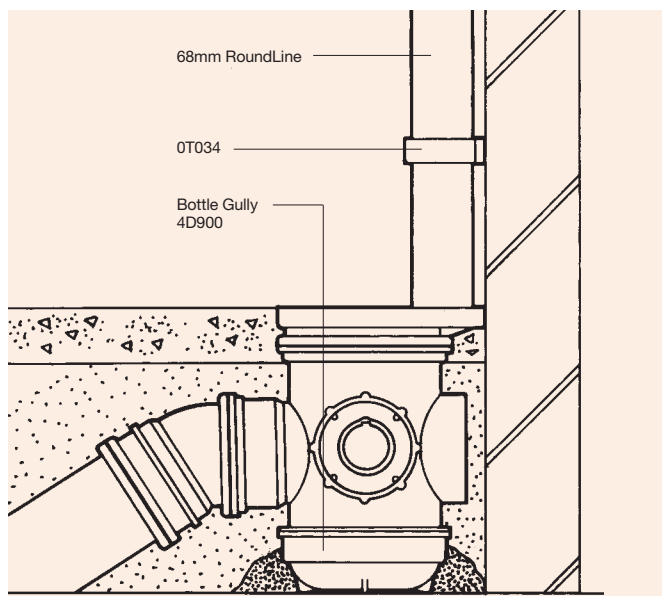

Figure 55: Connection to Bottle Gully (68mm Circular pipe illustrated)

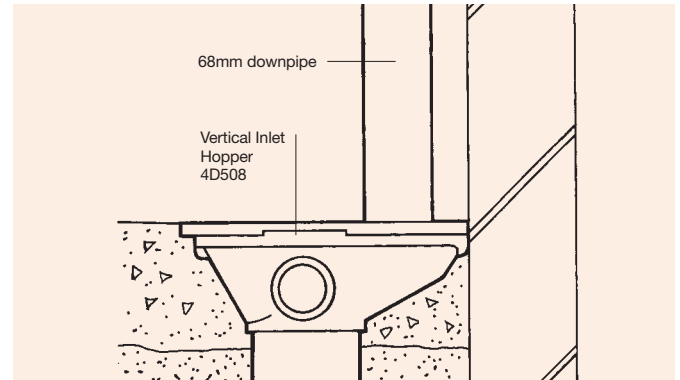

Figure 56: Connection to Bottle Gully (61mm square pipe illustrated)

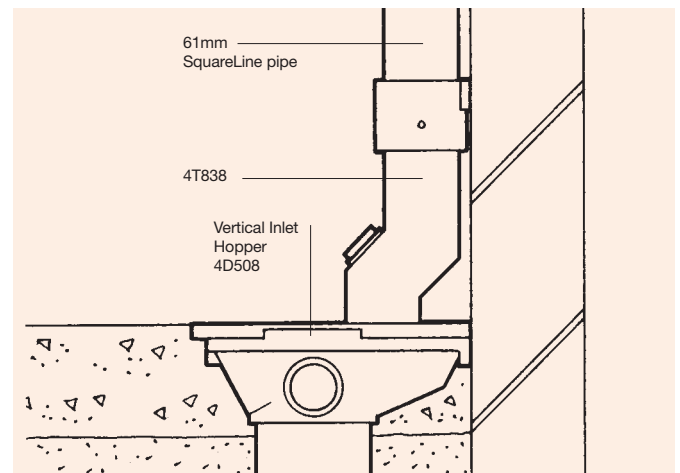
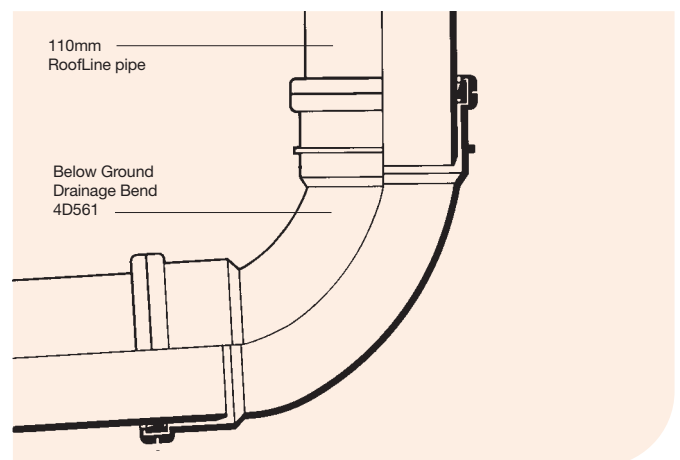

Figure 57: 110mm Connection to PVC-U Drain Socket



Connections to Existing Iron Pipe

68mm Circular Pipe

RoundLine, SuperLine, DeepLine, StormLine Systems

Rusty or cracked cast iron pipe may be replaced easily with PVC-U.

Any sound part of an existing cast iron system can be retained and 68mm PVC-U pipe connected directly to the open socket of a 2½" iron pipe. Mastic or other sealing compounds are not needed.

RoofLine, Osma Roof Outlets

To 4" Cast Iron Spigot

Component:

🔍 Connector 4S206 from the Osma Push-Fit Soil range.

Procedure

1. Fit Connector to the PVC-U pipe.
2. Push firmly into the socket.

Osma Rainwater

System Connections

Roof Outlets

Osma Roof Outlets are suitable for installation into any type of flat roof construction provided that there is adequate support. Typical constructions include mastic asphalt roofing and built-up roofing (see Figure 58).

Mastic Asphalt Roofing

Procedure

1. If not cast in-situ, ensure the outlet is suitably supported by shaping the concrete slab to receive the body. The flange may rest on top of the screed – no recess is required.
2. Drill four equally spaced counter sunk holes (N°.10 size) in centre of flange.
3. Fix Outlet to roof decking using 1" N°.10 rustless screws. Remove grating.
4. Dress first layer of asphalt up to and over the flange. Feather on the outer edge of the mouth recess.
5. Dress second layer of asphalt over the first. Finish by trowelling to a radius into the mouth recess.
6. Replace and secure grating.

Built-up Felt Roofing

Procedure

1. Provide a hole in the roof suitably dished to give support to the body and recess the flange level with the top of the roof deck.
2. Drill four equally spaced counter sunk holes (No.10 size) in centre of flange.
3. Fix Outlet to roof decking using 1" No.10 rustless screws. Remove grating.
4. Lay the first two layers of felt across the flange and into the mouth recess.
5. Lay the third layer and dress down into the mouth of the body. This will adhere to the Outlet with bitumen.
6. Replace grating over the third layer of felt and secure.

| Outlet (mm) | Min. size of hole required (mm) |
|-------------|---------------------------------|
| 82 | 185 |
| 110 | 240 |

Figure 58: Roof Outlet installation

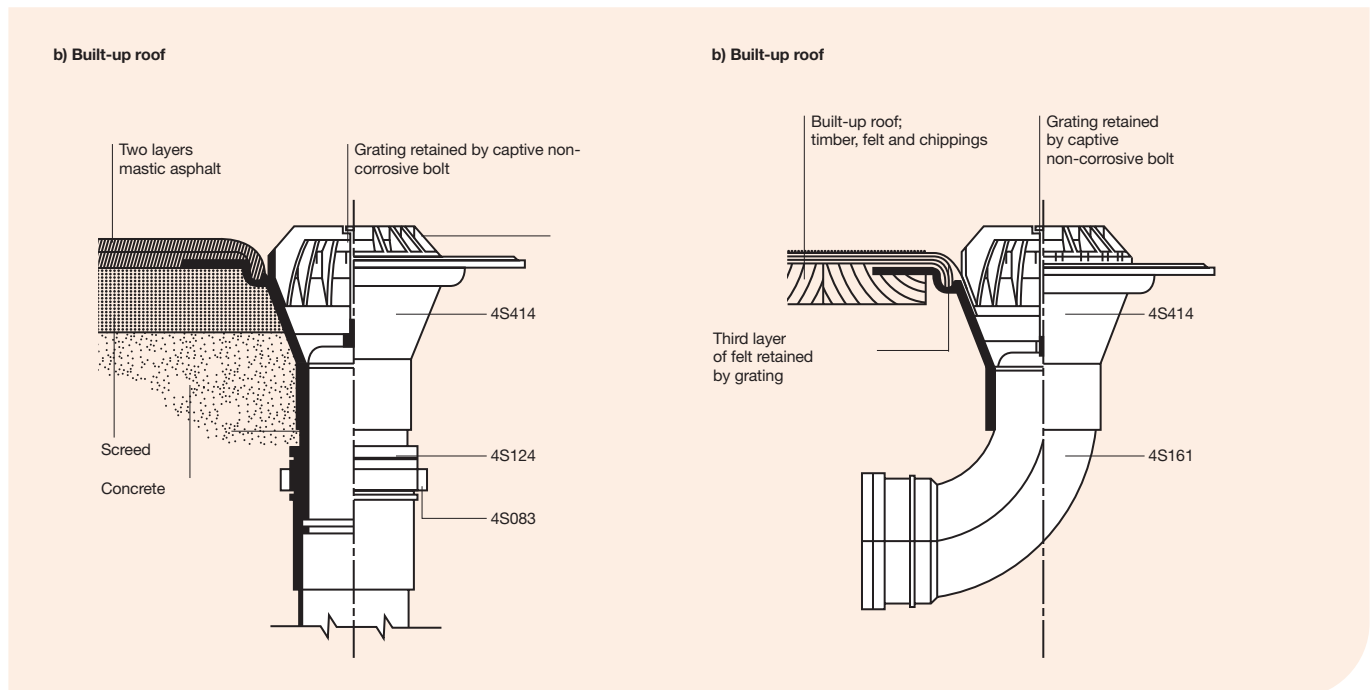

Pipe Jointing for 82mm and 110mm pipe

Both RoofLine gutter system and Osma Roof Outlets connect to Osma 110mm PVC-U soil pipe and fittings. Osma Roof Outlets also connect to Osma 82mm PVC-U soil pipe and fittings.

Joints in lengths of 82mm and 110mm pipe may be formed by:

- ⦿ Ring-seal, push-fit jointing OR
- ⦿ Solvent weld jointing

Three sockets are available:

- ⦿ D/SW Double Socket 3S/4S104
- ⦿ D/S Double Socket 3S/4S105 (slip coupler for repair applications)
- ⦿ S/SW Single Socket 3S/4S124 (for creating a fixed ring-seal joint on plain-ended pipe or fittings)

Ring-Seal/Push-fit jointing

Procedure

1. Ensure any pipe cut on site is also chamfered.
2. Check that the sealing ring is properly seated in its housing in the socket of the fitting.
3. Ensure all components to be joined are dry, clean and free from grit or dust. Note any deep scratches on the pipe or fitting spigot as these may prevent the sealing ring from forming a water tight seal.
4. Lubricate evenly around the pipe or fitting spigot end with Silicone Lubricant 4S391. Do NOT lubricate inside the socket. Do NOT use washing up liquid as a lubricant.
5. Correctly align the components to be joined.
6. Push the pipe or fitting spigot fully into the socket. Mark the pipe or fitting spigot at the socket face and then withdraw it by a minimum of 12mm.
7. Make a subsequent check to ensure that the expansion gap is not lost during further installation work.

Silicone Lubricant Allowance

50g tube 4S391: Sufficient for 9 joints of 110mm pipe and 16 joints of 82mm pipe.

Silicone Lubricant Spray

400ml can 4S392: Spray the lubricant onto the spigot and not the ring seal. The spigot can then be inserted into the socket. After installation ensure the pipework is thoroughly flushed through with clean water.

Solvent Weld Jointing

Procedure

1. Before using any solvent based cleaners or cement:
 - Read instructions on the can
 - Ensure there is sufficient ventilation.
2. Make sure pipe or fitting spigot and solvent weld socket are dry, clean and free from grit or dust.
3. Clean surfaces of spigot and socket with Degreasing Cleaner N°.1 4S379/380. Apply liberally using a clean non-synthetic rag or absorbent paper.
4. Apply one coat Solvent Cement N°.2 4S383/384/385. Apply an even coat to both surfaces using the applicator provided or a paint brush. Stroke the cement ALONG and not around the surfaces.
5. Immediately insert pipe or fitting spigot fully into the socket. Each solvent weld joint MUST be completed within 1½ minutes.
6. Hold for 20-30 seconds. Remove any surplus cement from the mouth of the socket.
7. The joint may be handled after 10 minutes and commissioned after 24 hours.

Degreasing Cleaner Allowance (approx.)

- ⦿ N°.1 - 125ml can 4S379: Sufficient for 16 joints of 110mm pipe
- ⦿ N°.1 - 250ml can 4S380: Sufficient for 32 joints of 110mm pipe

Solvent Cement Allowance

- ⦿ N°.2 - 125ml can 4S383: Sufficient for 5 joints of 110mm pipe
- ⦿ N°.2 - 250ml can 4S384: Sufficient for 11 joints of 110mm pipe
- ⦿ N°.2 - 500ml can 4S385: Sufficient for 22 joints of 110mm pipe

Safety

When making solvent weld joints it is essential to observe normal safety rules for handling solvent:

- ⦿ Never smoke or bring naked flames near the area of work
- ⦿ Work in a well ventilated area to avoid inhaling fumes
- ⦿ Close the solvent container after use and store in a cool area
- ⦿ Do not allow solvents or cleaners to come into contact with skin

Refer to COSHH Regulations (Control of Substances Hazardous to Health) where applicable.

Osma Rainwater

Quick Reference Guide

Preparation

Safety

- ⦿ Always comply with safety codes. In particular, ensure ladders are properly positioned and secured (Step 1)

Removing Old Guttering

- ⦿ Remove old gutter with care (especially if cast iron) and recycle if possible
- ⦿ Check condition of fascia: replace as necessary or use multi-hole screw fixings

Checking Gutter Suitability

To avoid rainwater overshooting edge of installed gutter:

- ⦿ Ensure the leading edge of the tile does not extend beyond the centreline of the proposed gutter
- ⦿ If it does, a larger section gutter or Bracket Spacers will be required (Step 2)

Planning Gutter Run

- ⦿ Gutters should be laid to a fall of 1:600 (i.e. 10mm for every 6m of the run)
- ⦿ Identify highest and lowest points on gutter run
- ⦿ Place Running Outlet above drainage connection: this is the lowest point
- ⦿ The furthest gutter fixing away from here will be the highest point (Steps 3 and 4)

Step 1



Step 2



Step 3



Step 4



Installation Techniques

Cutting Gutter and Downpipe

- ⦿ Cut 'squarely' using fine-toothed hand-saw, and de-burr (Steps 5 and 6)
- ⦿ If using 110mm pipe, chamfer spigot end before inserting into a ring seal (Step 7)

Inserting Gutter into Brackets/Fittings

- ⦿ Place far edge of gutter under the bracket clip nearest the fascia
- ⦿ Pull front edge of gutter down with your fingers while simultaneously pushing the outside clip over the gutter with your thumbs (Step 8)
- ⦿ Ensure edge of under-felt or membrane is dressed into the gutter (Step 9)

Allowing for Thermal Expansion

To prevent joints from moving apart under thermal movement:

- ⦿ All fittings must be secured to the building/fascia
- ⦿ Insert gutter to the depth-of-entry line
- ⦿ At changes of direction, place a support within 150mm either side of gutter angle

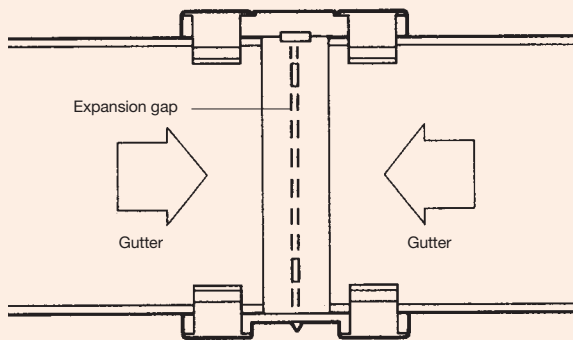

Pipe Bracket Fixings

- ⦿ Wherever possible, place fixing screws in sound mortar joint of brickwork

Step 5



Step 6



Step 7



Step 8



Step 9



Osma Rainwater

Quick Reference Guide

Installation Procedures – Gutters

- ⦿ Start at furthest point from outlet
- ⦿ Position Gutter Support Bracket as high as practicable under tile, ensuring sufficient room to fix the gutter using 1" N°. 10 round-head screws (Step 1)

Note: Where there are multiple fixing holes, we recommend using all of them. However, the central fixing hole is sufficient.

- ⦿ Use a plumbline to identify correct position of Running Outlet above underground drain inlet/connection (Step 2)
- ⦿ Allowing for the correct fall (1:600), position and fix Outlet (Step 3)
- ⦿ String a plumb line between the Gutter Support Bracket and the Outlet (Step 4)
- ⦿ Using the string as a guide, position other Gutter Support Brackets and Gutter Jointing Brackets at maximum 1 metre centres. Note: All fixing holes should be used (Step 5)

Continued opposite.

Step 1



Step 2



Step 3



Step 4



Step 5



- ⦿ Fix any Gutter Union or Gutter jointing bracket onto the gutter length before offering the gutter into position
- ⦿ If using a Gutter Angle, fit a Gutter Support Bracket within 150mm
- ⦿ When fixing the gutter, work from the outlet using full gutter length
- ⦿ Ensure correct depth-of-entry positions have been maintained in all fittings
- ⦿ Check position of each Gutter Jointing Bracket and fix to fascia. If you are using Gutter Unions, fix to the fascia using a Gutter Support Bracket (Step 6)
- ⦿ Continue to end of run or change of direction
- ⦿ Do NOT cut gutter to length until fixed position has been established and expansion gap confirmed
- ⦿ Attach Stopends (Step 7). If you are using a profiled system such as Osma StormLine, you will need left and right Stopends

See next page for downpipe installation.

Step 6



Step 7



Osma Rainwater

Quick Reference Guide

Installation Procedures – Downpipes

- Start from top

Use Offset Bends to create swan neck assembly:

- Place fittings in position at top of downpipe
- Measure length of pipe needed between Offset Bends
- Cut required length (Step 1)
- Fix Pipe Bracket directly under the Offset Bend
- Position Downpipe length(s) and support with Pipe Bracket at maximum 2 metre centres (Step 2)
- Fix any fittings (e.g. Pipe Connector) using Socket Bracket (Step 3)

Step 1



Step 2



Step 3



Installation Procedures – Connections to Drainage

There are several methods of directing rainwater out of downpipes into below ground drainage:

Direct Feed into a Vertical Inlet Hopper or Bottle Gully:

- ⌚ Cut a hole for the downpipe in the back plate of the Hopper – or remove section of Bottle Gully grating
- ⌚ Insert pipe, ensuring discharge is below grating (Step 1)

Soakaways:

- ⌚ Where drainage connections are not present, Wavin AquaCell should be used to create a soakaway (see Wavin AquaCell System: Product and Installation Guide) (Step 2)

Direct Connection to Underground Drainage Inlet:

- ⌚ There is a range of adaptors for connecting rainwater downpipes into underground drainage (Step 3)

Step 1



Step 2

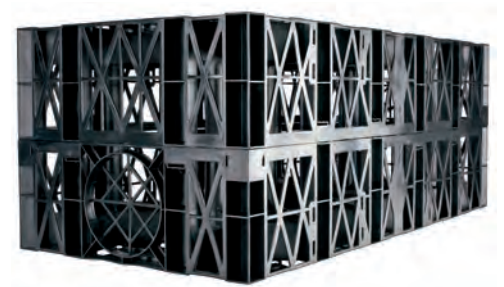

Step 3



Osma Rainwater

Quick Reference Guide

Installation Tips

Site Survey

- ⌚ You may find it useful to carry out a preliminary survey of a proposed installation from ground level using binoculars

Screws

- ⌚ 1" N° 10 round-head screws should be used on wooden fascias
- ⌚ For correct screws for plastic fascias, seek manufacturer's advice

IMPORTANT NOTE: Where there are multiple fixing holes, we recommend using all of them. However, the central fixing hole is sufficient.

Power Tools

- ⌚ Power tools can be used to install Osma guttering
- ⌚ For correct torque setting on plastic fascias, seek manufacturer's advice

Correct Setting of Bracket Levels

- ⌚ Support Brackets on Osma RoundLine and DeepLine incorporate a raised section at their invert to provide correct alignment for the string line. This enables all jointed fittings to be set correctly to the string line
- ⌚ On all other systems, jointed fittings will need to be aligned as installation proceeds, otherwise unions will not run to a level line

Gutter Support Centres

- ⌚ Gutter should be supported at maximum 1m intervals, within 150mm of both sides of any angle, and at the centre of gutter unions
- ⌚ In areas subject to heavy snowfalls, the distance between Support Brackets should be reduced to maximum 600mm or less

Lubricating Seals

- ⌚ Assembly is easier if the seal is lubricated using Osma Silicone Spray. Lubricant also improves service life and efficiency of seals

Leaves

- ⌚ Leaf Guard can be used where there are trees close to the roof (available for RoundLine only)



Rainwater Diverter

- ⌚ This is an excellent, environmentally friendly method of collecting roof water for garden use, whilst still ensuring flow to underground drainage if the storage unit is full

Heavy Duty Applications or Unsound Fascia Boards

- ⌚ Ensure that the brackets are fixing using all three fixing holes (not just the central one)
- ⌚ In areas subject to heavy snowfalls, the distance between Support Brackets should be reduced to maximum 600mm or less

Obtaining Plumb Vertical Drop for Downpipe

- ⌚ If you don't have a suitable spirit level, measure in from the edge of the wall to the proposed centreline. Do so at the top, middle and bottom of the wall

Timber Preservatives

- ⌚ Timber fascias treated with preservatives must be allowed to dry before fixing gutter and fittings

Water Test

- ⌚ Don't wait for a downpour – do a water test of new guttering before removing ladder



Osma Rainwater

General Information

Materials

All gutter, pipe and most fittings in Osma Rainwater systems are manufactured from PVC-U (Unplasticised Polyvinyl Chloride).

Acceptance

Osma Rainwater systems comply, where applicable, with the requirements of the following British Standards:

- BS 6209: 1982 Solvent cement for non-pressure thermoplastics pipe systems
- BS 1329-1: 2000 Plastics piping systems for soil and waste drainage
- BS EN 607: 2004 Eaves, gutters and fittings made of PVC-U definitions, requirements and testing. Approval pending
- BS EN 1462: 2004 Brackets for eaves gutters: requirements and testing. Approval pending
- BS EN 12200-1: 2000 Plastics rainwater piping systems for above ground external use – unplasticized Poly Vinyl Chloride (PVC-U) – Part 1 specification for pipes, fittings and the system. Approval pending



The British Standard Kitemark identifies gutter, pipe and fittings that are manufactured under the BSI certification scheme.

References

Osma Rainwater systems should be designed and installed in accordance with the guidance provided in the appropriate sections of the following:

- Building Regulations 2000 (England and Wales): Approved Document H, Part H1
- Building Standards (Scotland) Regulations 1993-2002 (including current amendments: Technical Standards Part M)
- Building Regulations (Northern Ireland) 2000: Technical Booklet N
- BS 8000 Workmanship on Building Sites: Part 13: 1989 Code of Practice for above ground drainage and sanitary appliances
- BS EN 12056: 2000 Gravity drainage systems inside buildings: Part 3 Roof drainage, layout and calculation
- Disposing of rainwater: GBG 38. Watford, BRE 2000
- Painting plastics: IP 11/1979. Watford, BRE 1979
- Water Regulations Guide: London, Water Regulations Advisory Scheme, 2000

Health and Safety

The relevant provisions of the following legislation should be adhered to on site:

- Construction (Design and Management) Regulations 1994
- Control of Substances Hazardous to Health Regulations 1988
- Health and Safety at Work Act 1974
- Management of Health and Safety at Work Regulations 1999
- Manual Handling Operations Regulations 1992

Hazards Associated with PVC-U

There are no particular hazards associated with handling, cutting or working with PVC-U products, and protective clothing or equipment is not normally required.

Copies of Safety Data Sheets covering PVC-U, solvent cements and cleaners are available from Wavin Technical Design Department. Contact Wavin Technical Enquiries.

Abbreviations

| Key | |
|-------|---|
| P/E: | Pipe and fittings with both ends plain or with one plain end and one special end |
| S/S: | Pipe and fittings with one or more ring-seal or push-fit sockets, but always one plain or special end |
| D/S: | Fittings with ring-seal or push-fit sockets at all ends |
| S/SW: | Fittings with one or more ring-seal sockets but always one solvent socket |
| SW/S: | Fittings with one or more solvent sockets and one plain or special end |
| D/SW | Fittings with solvent sockets at all ends |

Osma Rainwater

General Information

Supply

All Osma systems are supplied through a nationwide network of merchant distributors. For details of your nearest stockist, contact Wavin Customer Services.

Sealing Rings

Where applicable, Sealing Rings are supplied fitted to each component and are included in the price.

Conditions of Sale

The Company will not accept responsibility for the malfunction of any installation which includes components not supplied by Wavin Limited. Goods are sold subject to Company conditions of sale.

'How to' Videos

To accompany this brochure, there is a set of 'how to' Osma Rainwater videos to give guidance on a range of installation and maintenance issues.



They can be viewed at www.youtube.com/WavinUK under the Osma Rainwater playlist.

They currently include:

- ⦿ Installing a plastic guttering system
- ⦿ Allowing for gutter and downpipe expansion
- ⦿ Installing leaf guards
- ⦿ Installing an Osma rainwater diverter kit
- ⦿ Fixing a leaking gutter joint

- ⦿ Overview of Osma StormLine
- ⦿ Cleaning gutter
- ⦿ Cleaning offset bends
- ⦿ Cleaning downpipes via access fitting
- ⦿ Bringing faded guttering back to life

There is also an extensive list of Osma Soil and Waste videos, Hep₂O Plumbing and Underfloor heating systems.

Discover our broad portfolio at www.wavin.co.uk

Hot & Cold Water

Foul Water

Gas & Water Mains

Indoor Climate

Storm Water

Geotextiles

Soil & Waste



Wavin is part of Orbia, a community of companies working together to tackle some of the world's most complex challenges. We are bound by a common purpose: To Advance Life Around the World.



Wavin Limited | Registered Office | Edlington Lane | Doncaster | DN12 1BY
Tel. 0800 038 0088 | www.wavin.co.uk | info@wavin.co.uk

Wavin operates a programme of continuous product development, and therefore reserves the right to modify or amend the specification of their products without notice. All information in this publication is given in good faith, and believed to be correct at the time of going to press. However, no responsibility can be accepted for any errors, omissions or incorrect assumptions.

© 2021 Wavin Wavin reserves the right to make alterations without prior notice. Due to continuous product development, changes in technical specifications may change. Installation must comply with the installation instructions.